OKIDATA®

Service Manual

OL810

LED Page Printer

Adobe Acrobat printable reference
copy of the OKIDATA Service Training Manual.
09/17/97

Note: This Adobe Acrobat version of the Okidata Service Training Manual was built with the pictures rendered at 300 dpi, which is ideal for printing, but does not view on most displays well.

Service Guide OL810**0 About This Manual**

Front Cover	1
Manual Copyright	2

1 Specifications

1.1 Overview - General Information	3
1.2 Physical Specifications	4
1.3 Power Requirements	5
1.4 Environmental Conditions	6
1.5 Agency Approvals	7
1.6 Operational Specifications - Compatibility	8
....1.6.02 Emulations	9
....1.6.03 Fonts	10
....1.6.04 Front Panel Switches	11
....1.6.05 Interface Methods	12
....1.6.06 Menu Mode	13
....1.6.07 Paper Delivery Method	14
....1.6.08 Paper Feed Method	15
....1.6.09 Paper Loading	16
....1.6.10 Paper Out Detection	17
....1.6.11 Paper Trays	18
....1.6.12 Print Methods	19
....1.6.13 Print Resolution	20
....1.6.14 Print Speed	21
....1.6.15 Symbol Sets	22
1.7 Paper Specifications	23
1.8 Memory Specifications	24
1.9 Consumables	25
1.10 Options	26
1.11 Reliability	27

2 Principles of Operation

2.1 Principles of Operation - General Information	28
....2.1.02 Control Unit (CU)	29
.....Block Diagram: Control Unit	30
.....Main Control Board (OLMA)	31
.....Reception Control	32
.....Command Analysis Processing	33
.....Font Processing	34
.....Raster Buffer Read Operation	35
.....Engine Interface (I/F)	36
.....Memory Boards OLRA and OLRA-2 (Options)	37
.....Font Card (Option)	38
....2.1.03 Printer Unit (PU)	39

Table of Contents

Page

.....Block Diagram: Printer Unit	40
.....Engine Board Controller (LLAT)	41
.....EEPROM Operation	42
.....Power Supply Unit	43
.....High Voltage / Bias Voltage Circuits	44
.....Fuser Unit	45
.....Main Motor (Drum Motor)	46
.....LED Array	47
.....Registration Motor	48
.....DC Fan	49
.....Operation Panel	50
.....Second Paper Tray Mechanism	51
....2.1.04 Sensors and Switches	52
2.2 Product Operation - Electrostatic Printing	53
...Diagram: Printing Process	54
...Processes	55
3 Maintenance	
3.1 Maintenance - General Information	56
....3.1.02 Maintenance Items	57
....3.1.03 Maintenance Precautions	58
3.2 Disassembly/Assembly Procedures - General Information	59
....3.2.01 Preliminary Items	60
....3.2.02 Upper Cover	61
....3.2.03 Stacker Open Switch Assembly	62
....3.2.04 LED Head	63
....3.2.05 RS232 Interface Board (OLSA, Option)	64
....3.2.06 Memory Boards (OLRA-2 or OLRA, Options)	65
....3.2.07 Main Controller Board (OLMA) and Second Font Card Board (OLCA)	66
....3.2.08 Engine Controller Board (LLAT)	67
....3.2.09 Main Motor	68
....3.2.10 Idle Gear A, Idle Gear B, and Speed Reduction Gear	69
....3.2.11 DC Fan Assembly	70
....3.2.12 Power Supply Unit	71
....3.2.13 Cover Open Microswitch Assembly	72
....3.2.14 Paper Eject Roller Assembly	73
....3.2.15 Paper Eject Sensor Lever and Rollers	74
....3.2.16 Upper Unit	75
....3.2.17 Cover Open Switch Actuator	76
....3.2.18 Paper Eject Sensor Levers B and C	77
....3.2.19 Fusing Unit	78
....3.2.20 Metal Pressure Roller Assembly	79
....3.2.21 Registration Sensor Lever and Toner Sensor Lever	80
....3.2.22 Lock Lever Assembly	81

Table of Contents	Page
....3.2.23 LED Head Holder	82
....3.2.24 LED Holder Ground Plate	83
....3.2.25 Pressure Roller Assembly	84
....3.2.26 Transfer Charger Assembly	85
....3.2.27 Registration Roller Assembly	86
....3.2.28 High Voltage Connector	87
....3.2.29 Idle Gear and Post	88
....3.2.30 Paper Supply Unit	89
....3.2.31 Registration Motor	90
....3.2.32 Engine Connector Board, LLCC	91
....3.2.33 Hopping Roller A	92
....3.2.34 Separator	93
....3.2.35 Base Frame	94
....3.2.36 Ozone Filter	95
....3.2.37 Second Paper Feed Unit (Option)	96
....3.2.38 Second Paper Feed Unit Boards and Connectors	97
....3.2.39 Second Paper Supply Unit (Option)	98
....3.2.40 Cassette Spring (Second Paper Supply Unit)	99
....3.2.41 Registration Motor (Second Paper Supply Unit)	100
....3.2.42 Second Paper Supply Unit Control Board, LLFC	101
3.3 Adjustments And Service Settings - General Information	102
....3.3.01 Drum Counter Reset	103
....3.3.02 Darkness Control	104
....3.3.03 Switch 1 Maintenance Mode	105
.....Actual Page Count	106
.....Modified Page Count	107
.....Fuser Counter Reset	108
.....Vertical Print Start Position Adjustment	109
.....Chart of EEPROM Parameters and Print Start Positions	110
.....Setting the LED Head Drive Time	111
....3.3.04 Smoothing Select	112
....3.3.05 DC Voltage Check (+5 vdc)	113
....3.3.06 Menu Operation - General Information	114
.....Menu Mode	115
.....Printing the Menu	116
.....Sample	117
.....Reset Menu to Factory Defaults	118
.....Menu Settings - Primary Menu - HP LaserJet III Emulation	119
.....Menu Settings - Primary Menu - IBM ProPrinter III XL Emulation	120
.....Menu Settings - Secondary Menu - Both Emulations	121
....3.3.07 Key Combinations	122
....3.3.08 Resets	123
3.4 Cleaning	124

Table of Contents

Page

....3.4.02 Static Charger	125
....3.4.03 Transfer Charger	126
3.5 Lubrication	127
3.6 Shipping Instructions	128
4 Failure Analysis	
4.1 Overview - Introduction	129
....4.1.02 Printer Serial Number Identification	130
....4.1.03 Firmware Revision Identification	131
4.2 Reporting Problems	132
4.3 Troubleshooting Updates	133
4.4 Troubleshooting Tips	134
4.5 Abnormal Output	135
4.6 Fault Alarms - Using The Error Message Charts	136
....4.6.02 Error Messages: Operator Lamp Flashes (Chart A)	137
....4.6.03 Error Messages: Operator Lamp Does Not Flash (Chart B)	138
4.7 Repair Analysis Procedures (RAPS) - Using The RAPS	139
....4.7.02 RAP Index	140
.....RAP 01: Printer Does Not Initialize	141
.....RAP 02: Paper Feed Jam	142
.....RAP 03: Paper Jam	143
.....RAP 04: Paper Size Error	144
.....RAP 05: Fusing Problem	145
.....RAP 06: PU Error	146
.....RAP 07: Operator Panel Communication Error	147
.....RAP 08: Communication Error Between PU and CU	148
.....RAP 09: Loop Test Failure (RS-232C)	149
.....RAP 10: Resident/Optional RAM Failure	150
.....RAP 11: Program ROM Failure	151
.....RAP 12: Optional Font Card Failure	152
.....RAP 13: Receive Buffer Overflow	153
.....RAP 14: No Display on Operator Panel	154
.....RAP 15: Images are Light or Blurred	155
.....RAP 16: Dark Background Density	156
.....RAP 17: Blank Paper is Output	157
.....RAP 18: Black Vertical Stripes	158
.....RAP 19: Evenly Spaced Marks on Output	159
.....RAP 20: Random Missing Output	160
.....RAP 21: White Vertical Stripes	161
.....RAP 22: Black Page is Output	162
.....RAP 23: Printing Incorrect Characters	163
4.8 Printer Tests - General Information	164
....4.8.01 Continuous Print (Rolling ASCII) Test	165
....4.8.02 Font Sample Test	166

Table of Contents

Page

....4.8.03 Hexadecimal Dump Mode	167
....4.8.04 Serial Interface Loopback Test	168
....4.8.05 Engine Test A	169
....4.8.06 Engine Test B	170
....4.8.07 Menu Print	171
....4.8.08 Demo Page Print	172
A Board Diagrams	
A.1 Overview - General Informationboard Diagrams	173
A.2 Index To Charts	174
....A.2.01 Main Controller Board (OLMA)	175
....A.2.02 Engine Controller Board (LLAT)	176
....A.2.03 Operator Panel Board (LLJB-2)	177
....A.2.04 Engine Connection Board (LLCC)	178
....A.2.05 Second Font Card Board (OLCA)	179
....A.2.06 Power Connection Board (LLID)	180
....A.2.07 Power Supply Unit	181
....A.2.08 RS232-C Interface Board (OLSA) Option	182
....A.2.09 Memory Boards (OLRA and OLRA-2) Options	183
....A.2.10 Second Paper Feed Unit Controller (LLFC) Option	184
....A.2.11 Second Paper Feed Unit Connection Board (LLIG) Option	185
....A.2.12 Second Paper Feed Unit Connection Board (LLIF) Option	186
B Illustrated Parts Listing	
B.1 Overview	187
....B.1.02 Definition of Terms	188
....B.1.03 Parts Ordering Information	189
B.2 Charts	190
....B.2.01 Printer	191
....B.2.02 Printer Unit	192
....B.2.03 Paper Trays	193
....B.2.04 Upper Unit (1 of 2)	194
.....Wrong diagram : Jim Fitzpatrick/Project Leader/Okidata; 11/12/96	195
....B.2.05 Upper Unit (2 of 2)	196
....B.2.06 LED Holder	197
....B.2.07 Lower Unit (1 of 2)	198
....B.2.08 Lower Unit (2 of 2)	199
....B.2.09 Boards	200
....B.2.10 Paper Eject Roller Assembly	201
....B.2.11 Paper Supply Unit	202
....B.2.12 Options	203
....B.2.13 Font Cards	204
....B.2.14 Second Paper Feed Unit	205

Table of Contents**Page**

....B.2.15 Packing Materials	206
....B.2.16 Consumables	207
....B.2.17 Documentation	208
....B.2.18 Service Training Kit Revisions	209



Service Guide OL810 Chapter 0 About This Manual

This document may not be reproduced without the written permission of the Okidata Technical Training Group. Every effort has been made to ensure the accuracy of the information contained in this training course. Okidata is not responsible for errors beyond its control.

Copyright 1994 by Okidata All rights reserved.

First Edition May, 1992 P/N 58225901

Second Edition June, 1993 P/N 58225902

Third Edition November, 1994 P/N 58225903

Written and produced by the Okidata Technical Training Group

Please address any comments on this publication to:

Okidata

Attn: Publications

532 Fellowship Road

Mount Laurel, NJ 08054-3499

OKIDATA is a registered trademark of Oki Electric Industry Company, Ltd.; marques deposee de Oki Electric Industry Company, Ltd.; marca registrada, Oki Electric Industry Company, Ltd.

Bitstream is a registered trademark and Dutch, Fontware, and Swiss are trademarks of Bitstream, Inc. Fontware is licensed to Bitstream, Inc., in West Germany, France, and the United Kingdom by Electronic Printing Systems, Ltd.

Centronics is a registered trademark of the Centronics Corporation

Hewlett-Packard, HP, LaserJet, LaserJet+, LaserJet Series II, and LaserJet Series III are registered trademarks of Hewlett-Packard Company.

IBM, PC, PC-DOS, and Proprinter XL are registered trademarks of International Business Machines Corporation.

ITC Zapf Dingbats is a registered trademark of International Typeface Corporation.

Copyright 1997, Okidata, Division of OKI America, Inc. All rights reserved. See the OKIDATA Business Partner Exchange (BPX) for any updates to this material. (<http://bpx.okidata.com>)

1.1 OVERVIEW

1.1.01 General Information

The OL810 is a desktop page printer, using a stationary LED head and dry electrophotography as its exposure and development methods. The printer has a resolution of 300 x 300 dots per inch and a continuous print speed of 8 letter-sized sheets per minute.

A one megabyte page memory is standard. It can be expanded (with two optional RAM printed circuit boards) for a total of five megabytes of printer memory. The OLRA memory board increases available RAM by 2 megabytes. The OLRA-2 memory board increases available RAM by 1 megabyte. Two optional memory boards can be installed at the same time.

The printer features Oki Smoothing Technology (OST). The OST LED head provides edge smoothing to reduce the jagged stairstep effects of bitmapped images for improved print quality. The OST capability is selected through the SMOOTHING option of the printer menu. The default setting is SMOOTHING ON.

Two emulations are available. The HP LaserJet III emulation has 42 fonts. The IBM Proprinter III XL emulation includes 26 fonts. Two optional font cards slots are available. Downloadable fonts are also accepted.

A Centronics parallel interface is standard. An RS-232C serial interface is available as an option. Two consumables are used in the printer. The toner cartridge kit contains a toner cartridge, a fuser cleaner pad, and an LED lens cleaner. The other consumable, the image drum cartridge kit, includes an image drum cartridge and an ozone filter.

A letter-size paper tray is included with the printer. Legal, envelope, executive, and A4 trays are also available. Paper feeding can be done automatically or manually.

The printer will print on a variety of paper types, labels, envelopes, and transparencies.



1.2 PHYSICAL SPECIFICATIONS

1.2.01 Dimensions

Width: 17.72 inches (450 millimeters)

Height: 6.02 inches (153 millimeters)

Depth: 17.72 inches (450 millimeters) [Does not include paper tray]

1.2.02 Weight

24 pounds (approximately 11 kilograms) [Without options]

Copyright 1997, Okidata, Division of OKI America, Inc. All rights reserved. See the OKIDATA Business Partner Exchange (BPX) for any updates to this material. (<http://bpx.okidata.com>)

1.3 POWER REQUIREMENTS**1.3.01 Input Power**

120 VAC +5.5%, -15%
220/240 VAC +/-10%

1.3.02 Power Consumption

Approximately 800 W maximum during operation
Approximately 22 W maximum during stand-by (Fuser is OFF)

Copyright 1997, Okidata, Division of OKI America, Inc. All rights reserved. See the OKIDATA Business Partner Exchange (BPX) for any updates to this material. (<http://bpx.okidata.com>)

1.4 ENVIRONMENTAL CONDITIONS**1.4.01 Acoustic Rating**

Operation: 50 dB maximum
QUIET Mode: 43 dB maximum

1.4.02 Altitude

10,000 feet (3,050 meters)

1.4.03 Ambient Temperature and Relative Humidity

While operating:
50 to 90 degrees Fahrenheit (10 to 32 degrees Celsius)
20 to 80% Relative Humidity
While in storage:
- 4 to 110 degrees Fahrenheit (- 20 to 43 degrees Celsius)

Copyright 1997, Okidata, Division of OKI America, Inc. All rights reserved. See the OKIDATA Business Partner Exchange (BPX) for any updates to this material. (<http://bpx.okidata.com>)



1.5 AGENCY APPROVALS

1.5.01 Listings

FCC Class B

UL478 Version 5

CSA 22.2 220

Radio Frequency Interference (RFI)

Canadian Department of Communications Radio Interference Regulations

Copyright 1997, Okidata, Division of OKI America, Inc. All rights reserved. See the OKIDATA Business Partner Exchange (BPX) for any updates to this material. (<http://bpx.okidata.com>)



1.6 OPERATIONAL SPECIFICATIONS

1.6.01 Compatibility

Standard

HP LaserJet II

HP LaserJet III / IIIP

IBM ProPrinter IIIXL

Option

Diablo 630

Adobe PostScript with ATM 2.0

Auto Emulation Switching Software

Adobe Type Manager Software

Copyright 1997, Okidata, Division of OKI America, Inc. All rights reserved. See the OKIDATA Business Partner Exchange (BPX) for any updates to this material. (<http://bpx.okidata.com>)



1.6.02 Emulations

Standard

HP LaserJet II

HP LaserJet III / IIIP

IBM ProPrinter IIIXL

Option

Diablo 630

Adobe PostScript with Adobe Type Manager 2.0

Copyright 1997, Okidata, Division of OKI America, Inc. All rights reserved. See the OKIDATA Business Partner Exchange (BPX) for any updates to this material. (<http://bpx.okidata.com>)



Service Guide OL810

Chapter 1 Specifications

1.6.03 Fonts - Resident

HP III Emulation: 42 resident fonts

IBM Proprinter III XL Emulation: 26 resident font styles

13 Scalable Resident Fonts

CG Times, Univers, Univers Condensed, ITC Zapf Dingbats

Available in various styles and weights.

42 Bitmap Resident Fonts

All styles portrait and landscape

Courier 10 point, Courier 12 Point, Dutch 8 point, Dutch 10 point, Dutch 10 point compressed, LN Printer, Swiss

Resident Fonts

13 Scalable:

CG Times, **Bold**, *Italic*, **Bold Italic**
 Univers®, **Bold**, *Italic*, **Bold Italic**
 Univers Condensed, **Bold**, *Italic*, **Bold Italic**
 ITC Zapf Dingbats ★ ○ □ ♥ ♦ ♣

42 Bitmap Fonts:

(all styles portrait and landscape)

Courier 10pt. Medium, **Bold**, *Italic*
 Courier 12pt. Medium, **Bold**, *Italic*
 Dutch™ 8pt. Medium (B&F)* Medium Compressed (B)
 Dutch 10pt. Medium (B), **Bold** (B), *Italic* (B)
 Dutch 10pt. (Compressed) Medium (B&F), **Bold** (B&F), *Italic* (B&F)
 LN Printer 8.5 Medium (P&L)
Swiss™ Bold 14.4pt. (B&F)

Optional

Bitmap Font Cards

Roman

Prestige Elite

Letter Gothic

OkiPro 65

MicroDocs

TAX

BarCodes Plus

Scalable Font Cards

WP Scalable

Dazzling Presentations

Special Documents

WP Scalable -
Part # 70021501
(HP=WordPerfect Scalable)

CG Century Schoolbook™
CG Century Schoolbook Italic
CG Century Schoolbook Bold
CG Century Schoolbook Bold Italic
CG Palacio™
CG Palacio Italic
CG Palacio Bold
CG Palacio Bold Italic
Futura™ Book II
Futura Book Italic II
Futura Bold II
Futura Bold Italic II
Dem™ Casual
ITC Galliard™
ITC Galliard Italic
ITC Galliard Bold
ITC Galliard Bold Italic
Albertus™ Medium
Albertus Extrabold
Flt™ Zapf Chancery™ Medium Italic
Microstyle Bold

Dazzling Presentations -
Part # 70021401 (HP=Brilliant
Present. I/Compelling Pubs. II)

ITC Benguiat™ Book
ITC Benguiat Book Italic
ITC Benguiat Bold
ITC Benguiat Bold Italic
CG Bodini™ Book
CG Bodini Book Italic
CG Bodini Bold
CG Bodini Bold Italic
ITC Bookman™ Light
ITC Bookman Light Italic
ITC Bookman Demi
ITC Bookman Demi Italic
Cooper Black
Garamond™ Antiqua
Garamond Halbfett™
Garamond Kursiv
Garamond Kursiv Halbfett
CG Omega™
CG Omega Italic
CG Omega Bold
CG Omega Bold Italic
Revue™
Shannon™ Book
Shannon Oblique
Shannon Bold
Shannon Extrabold

Special Documents -
Part # 70021301
(HP= Distinctive Docs. I/
Compelling Pubs. I)

Antique Olive™
Antique Olive Italic
Antique Olive Bold
Antique Olive Compact
CG Century Schoolbook
CG Century Schoolbook Italic
CG Century Schoolbook Bold
CG Century Schoolbook Bold Italic
CG Palacio
CG Palacio Italic
CG Palacio Bold
CG Palacio Bold Italic
ITC Souvenir™ Light
ITC Souvenir Light Italic
ITC Souvenir Demi
ITC Souvenir Demi Italic
Stymie™ Medium
Stymie Medium Italic
Stymie Bold
Stymie Bold Italic

1.6.04 Front Panel Switches

MENU 1 / *Menu 2*
ENTER / *Quiet*
LAST - / *Smoothing*
NEXT + / *Demo*
RECOVER / *Reset*
PRINT FONTS / *Print Menu*
FORM FEED / *Tray Select*
ON-LINE /
Italicized Items

To access, press switch for two seconds.

Copyright 1997, Okidata, Division of OKI America, Inc. All rights reserved. See the OKIDATA Business Partner Exchange (BPX) for any updates to this material. (<http://bpx.okidata.com>)



Service Guide OL810

Chapter 1 Specifications

1.6.05 Interface Methods - Standard

Centronics Parallel Interface

Optional

RS-232C Serial Interface

Auto Interface Switching (with RS-232 Option)

AppleTalk (with PostScript option)

Copyright 1997, Okidata, Division of OKI America, Inc. All rights reserved. See the OKIDATA Business Partner Exchange (BPX) for any updates to this material. (<http://bpx.okidata.com>)

1.6.06 Menu Mode

Menu 1

Press ON-LINE to take the printer OFF-LINE. (READY will not be lit)

Press MENU 1

Menu 2

Press ON-LINE to take the printer OFF-LINE. (READY will not be lit)

Press MENU 1 / Menu 2 for more than two seconds

Printing the Menu

Press ON-LINE to take the printer OFF-LINE. (READY will not be lit)

Press and hold PRINT FONTS / PRINT MENU until the message PRINT MENU is displayed in the message window.

Each menu has several categories.

To move between categories, press MENU 1.

Each menu category has several possible settings.

The current setting is indicated by an asterisk.

To view the settings, press NEXT + to move to the next setting.

Press LAST - to move to the previous setting.

When the desired setting is displayed, press ENTER to select and store the setting.

Press MENU 1 to bring up the next menu category.

To save the menu changes / settings and exit menu mode, press RESET.

For more information regarding the menu, refer to Section Three of this Service Handbook or the Printer Handbook.



1.6.07 Paper Delivery Method

Face down
200 sheets capacity
Face up
100 sheet capacity

Copyright 1997, Okidata, Division of OKI America, Inc. All rights reserved. See the OKIDATA Business Partner Exchange (BPX) for any updates to this material. (<http://bpx.okidata.com>)



Service Guide OL810

Chapter 1 Specifications

1.6.08 Paper Feed Method

Automatic Feed
Standard Tray (Top)
Optional Second Tray (Bottom)
Manual Feed

NOTE: Use Manual or Standard Tray (Top) for single sheet, envelopes, labels, and transparencies.

Copyright 1997, Okidata, Division of OKI America, Inc. All rights reserved. See the OKIDATA Business Partner Exchange (BPX) for any updates to this material. (<http://bpx.okidata.com>)

1.6.09 Paper Loading

Automatic
200 sheet capacity, standard
200 sheet capacity, optional
Manual
One sheet at a time

Copyright 1997, Okidata, Division of OKI America, Inc. All rights reserved. See the OKIDATA Business Partner Exchange (BPX) for any updates to this material. (<http://bpx.okidata.com>)

1.6.10 Paper Out Detection**Standard Tray (Top)**

The paper end lever in the paper supply unit contacts the paper.

When paper is installed, the lever clears sensor S1 on the engine connection board.

When paper is not installed, the lever blocks sensor S1 on the engine connection board.

Optional Second Tray (Bottom)

The paper end lever in the optional second paper feed unit contacts the paper.

When the optional second paper feed unit is installed, the lever clears sensor S1 on the second paper feed unit controller.

When the optional second paper feed unit is installed, the lever blocks sensor S1 on the second paper feed unit controller.



1.6.11 Paper Trays

Letter
Legal
Executive
A4
Envelope
Universal

Copyright 1997, Okidata, Division of OKI America, Inc. All rights reserved. See the OKIDATA Business Partner Exchange (BPX) for any updates to this material. (<http://bpx.okidata.com>)

1.6.12 Print Methods

Development Method

Dry electrophotography

Exposure Method

Stationary LED Head (LED Array)

Number of LED Elements: 2560

CAUTION: *The OST LED Head for the OL810 is NOT interchangeable with non-OST printers.*

Copyright 1997, Okidata, Division of OKI America, Inc. All rights reserved. See the OKIDATA Business Partner Exchange (BPX) for any updates to this material. (<http://bpx.okidata.com>)

1.6.13 Print Resolution

300 x 300 dots/inch

Oki Smoothing Technology

Creates a series of "sub-scans" which allow the printer to automatically modulate the size and placement of the dots used to form characters and images.

Through this combination of larger and smaller dots, the boundaries of letters and curves are filled in and smoothed out. This results in straighter edges, curves that really curve, sharper corners and crisper type.

1-6-08.pcx

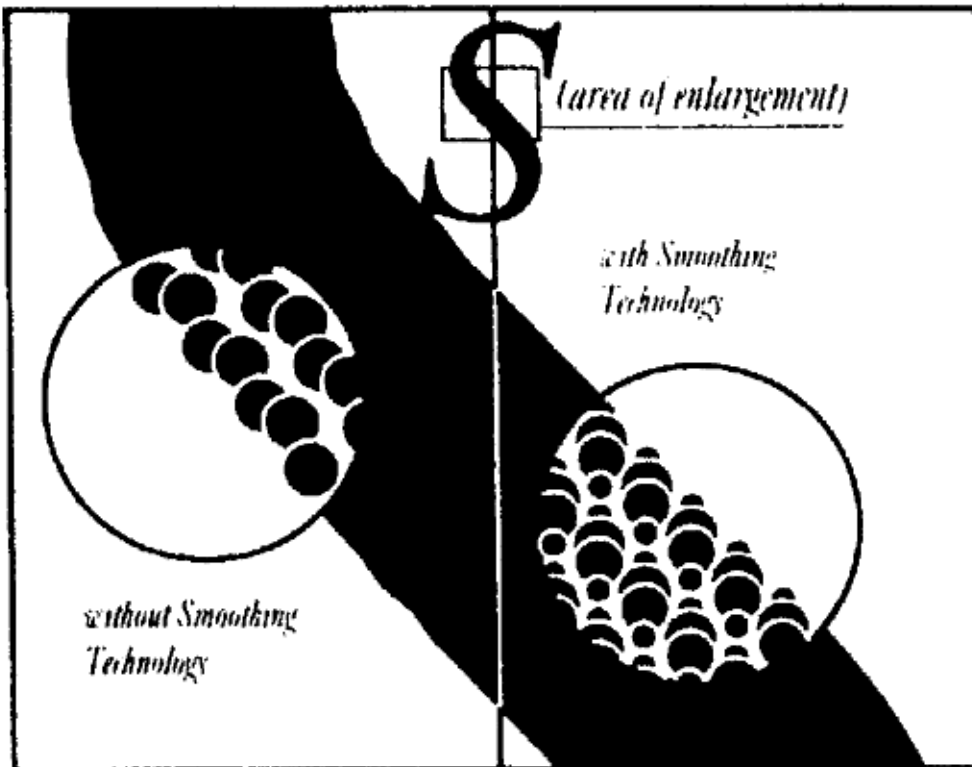



1.6.14 Print Speed

First print: 28 seconds maximum (letter size)

Continuous print: 8 sheets per minute (letter size)

Warm-up time: 45 seconds maximum temperature 77 degrees Fahrenheit (25 degrees Celsius) and rated voltage (120 VAC)

Copyright 1997, Okidata, Division of OKI America, Inc. All rights reserved. See the OKIDATA Business Partner Exchange (BPX) for any updates to this material. (<http://bpx.okidata.com>)



Service Guide OL810

Chapter 1 Specifications

1.6.15 Symbol Sets

Thirty-nine symbol sets are available through the OL810.

Copyright 1997, Okidata, Division of OKI America, Inc. All rights reserved. See the OKIDATA Business Partner Exchange (BPX) for any updates to this material. (<http://bpx.okidata.com>)

1.7 PAPER SPECIFICATIONS

1.7.01 Types

CAUTION:

All items must be designed for xerographic (laser) printing.

All items must be designed to withstand the heat of the fusing process (190 degrees Celsius and above).

Envelopes, labels, and transparencies should only be fed from the top paper tray or manually.

DO NOT use the optional second paper feed mechanism for envelopes, labels, or transparencies.

Envelopes should not have flaps or seams that cross the print area.

Use a wove or bond texture paper. Avoid cockle, linen, or laid paper.

Okidata DOES NOT recommend using embossed paper.

Okidata DOES NOT recommend using coated papers (unless they are specifically designed for laser printers).

Avoid papers with high cotton or rag content. 100% wood pulp papers work the best.

Pre-printed forms MUST BE printed with a heat resistant ink that can withstand the heat of the fusing process (190 degrees Celsius and above).

Cutouts are pages with some portion removed. The printer will print on pages with cutouts less than 0.375" in diameter. The print must be more than 0.1" from the edge of the cutout.

The printer will print to within 0.1" from the edge of a ring hole or perforation. Make sure that the holes and perforations are clean and free of burrs. Burred perforations may cause paper jams.

Letter

Weight: Minimum: 16 lbs. (60 g/m²)

Maximum: 24 lbs. (90 g/m²)

Recommended: 20 lbs. (75 g/m²)

Width: 8.5 inches (216 millimeters)

Length: 11 inches (279 millimeters)

Paper Feed Path: Automatic

Manual

Paper Delivery: Face up

Face Down

Notes: Must be designed for xerographic (laser) printing

Must be designed to withstand the heat of the fusing process (190 degrees Celsius and above)

Legal

Weight: Minimum: 16 lbs. (60 g/m²)

Maximum: 24 lbs. (90 g/m²)

Recommended: 20 lbs. (75 g/m²)

Width: 8.5 inches (216 millimeters)
Length: 14 inches (356 millimeters)
Paper Feed Path: Automatic (with optional paper tray)
Manual
Paper Delivery: Face up
Face Down
Notes: Must be designed for xerographic (laser) printing
Must be designed to withstand the heat of the fusing process (190 degrees Celsius and above)

Executive

Weight: Minimum: 16 lbs. (60 g/m²)
Maximum: 24 lbs. (90 g/m²)
Recommended: 20 lbs. (75 g/m²)
Width: 7.25 inches (184 millimeters)
Length: 10.5 inches (267 millimeters)
Paper Feed Path: Automatic (with optional paper tray)
Manual
Paper Delivery: Face up
Face Down
Notes: Must be designed for xerographic (laser) printing
Must be designed to withstand the heat of the fusing process (190 degrees Celsius and above)

A4

Weight: Minimum: 16 lbs. (60 g/m²)
Maximum: 24 lbs. (90 g/m²)
Recommended: 20 lbs. (75 g/m²)
Width: 8.27 inches (210 millimeters)
Length: 11.69 inches (297 millimeters)
Paper Feed Path: Automatic (with optional paper tray)
Manual
Paper Delivery: Face up
Face Down
Notes: Must be designed for xerographic (laser) printing
Must be designed to withstand the heat of the fusing process (190 degrees Celsius and above)

A5

Weight: Minimum: 16 lbs. (60 g/m²)
Maximum: 24 lbs. (90 g/m²)
Recommended: 20 lbs. (75 g/m²)
Width: 5.83 inches (148 millimeters)
Length: 8.27 inches (210 millimeters)
Paper Feed Path: Automatic (with optional paper tray)
Manual
Paper Delivery: Face up
Face Down
Notes: Must be designed for xerographic (laser) printing
Must be designed to withstand the heat of the fusing process (190 degrees Celsius and above)

A6

Weight: Minimum: 16 lbs. (60 g/m²)
Maximum: 24 lbs. (90 g/m²)
Recommended: 20 lbs. (75 g/m²)
Width: 4.13 inches (105 millimeters)
Length: 5.83 inches (148 millimeters)

Paper Feed Path: Automatic (with optional paper tray)

Manual

Paper Delivery: Face up

Face Down

Notes: Must be designed for xerographic (laser) printing

Must be designed to withstand the heat of the fusing process (190 degrees Celsius and above)

B6

Weight: Minimum: 16 lbs. (60 g/m²)

Maximum: 24 lbs. (90 g/m²)

Recommended: 20 lbs. (75 g/m²)

Width: 7.17 inches (182 millimeters)

Length: 10.12 inches (257 millimeters)

Paper Feed Path: Automatic (with optional paper tray)

Manual

Paper Delivery: Face up

Face Down

Notes: Must be designed for xerographic (laser) printing

Must be designed to withstand the heat of the fusing process (190 degrees Celsius and above)

Envelope

Weight: Minimum: 16 lbs. (60 g/m²)

Maximum: 24 lbs. (90 g/m²)

Recommended: 20 lbs. (75 g/m²)

Size: Minimum: 3.5 x 7.5 inches (89 x 191 millimeters)

Maximum: 7.2 x 10.1 inches (183 x 275 millimeters)

Business 4.12 x 9.5 inches (105 x 241 millimeters)

C5 6.4 x 9.12 inches (163 x 232 millimeters)

DL 4.36 x 8.77 inches (111 x 223 millimeters)

Monarch 3.87 x 7.5 inches (98 x 191 millimeters)

Paper Feed Path: Automatic (with optional paper tray) top paper tray ONLY

Manual

Paper Delivery: Face up ONLY

Notes: Must be designed for xerographic (laser) printing

Must be designed to withstand the heat of the fusing process (190 degrees Celsius and above)

Face up deliver ONLY

ONLY feed from the top paper tray *OR* manually

Do NOT use envelopes with this design.

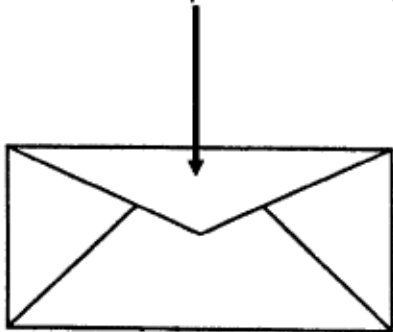

Use envelopes with this design.

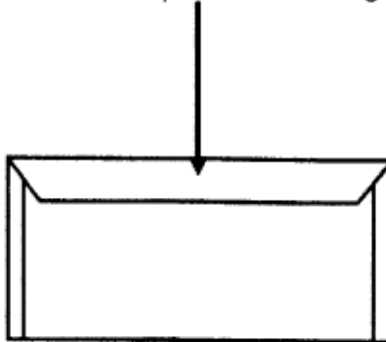

Labels

Weight: Minimum: 16 lbs. (60 g/m²)

Maximum: 24 lbs. (90 g/m²)

Recommended: 20 lbs. (75 g/m²)
Width: 8.5 inches (216 millimeters)
Length: 14 inches (356 millimeters)
Paper Feed Path: Automatic top paper tray ONLY
Manual
Paper Delivery: Face up ONLY
Notes: Must be designed for xerographic (laser) printing
Must be designed to withstand the heat of the fusing process (190 degrees Celsius and above)
Face up deliver ONLY
ONLY feed from the top paper tray *OR* manually

Transparencies

Weight: Minimum: 16 lbs. (60 g/m²)
Maximum: 24 lbs. (90 g/m²)
Recommended: 20 lbs. (75 g/m²)
Width: 8.5 inches (216 millimeters)
Length: 14 inches (356 millimeters)
Paper Feed Path: Automatic (top paper tray ONLY)
Manual
Paper Delivery: Face up ONLY
Notes: Must be designed for xerographic (laser) printing
Must be designed to withstand the heat of the fusing process (190 degrees Celsius and above)
Face up deliver ONLY
ONLY feed from the top paper tray *OR* manually



Service Guide OL810

Chapter 1 Specifications

1.8 MEMORY SPECIFICATIONS

1.8.01 EEPROM

EEPROM stands for Electronically Erasable Programmable Read Only Memory

Main Controller EEPROM

1024 x 1 bit serial input/output

Engine Controller EEPROM

1024 x 1 bit serial input/output

1.8.02 ROM

Main Controller Program ROM (2)

1 Mbyte

1 Mbyte

Engine Controller ROM

None installed; masked to the CPU

1.8.03 RAM

Resident RAM = 1 Mbyte

Expansion RAM (Options)

Memory Board (OLRA-2)

One Mbyte

Memory Board (OLRA)

Two Mbyte

NOTES:

Total installed RAM cannot exceed 5 Mbyte

Two optional memory boards can be installed at the same time in the OL810.

Standard Memory (1 Mbyte)	Optional OLRA-2 (1 Mbyte)	Optional OLRA-2 (1 Mbyte)	Optional OLRA (2 Mbyte)	Optional OLRA (2 Mbyte)	Total Memory
Installed					1 Mbyte
Installed	Installed				2 Mbyte
Installed	Installed	Installed			3 Mbyte
Installed			Installed		3 Mbyte
Installed	Installed		Installed		4 Mbyte
Installed			Installed	Installed	5 Mbyte

1.8.03 RAM

Resident RAM = 1 Mbyte

Expansion RAM (Options)

Memory Board (OLRA-2)

One Mbyte

Memory Board (OLRA)

Two Mbyte

NOTES:

Total installed RAM cannot exceed 5 Mbyte

Two optional memory boards can be installed at the same time in the OL810.

Copyright 1997, Okidata, Division of OKI America, Inc. All rights reserved. See the OKIDATA Business Partner Exchange (BPX) for any updates to this material. (<http://bpx.okidata.com>)

1.9 CONSUMABLES**1.9.01 Image Drum Cartridge Kit***Includes:*

Image Drum Cartridge
Ozone Filter

1.9.02 Toner Cartridge Kit*Includes:*

Toner Cartridge
Fuser Cleaner Pad
LED Lens Cleaning Pad

1.9.03 Toxicity

No carcinogens are contained



Service Guide OL810

Chapter 1 Specifications

1.10 OPTIONS

1.10.01 Memory Boards (RAM Expansion)

Memory Board (OLRA-2)

One Mbyte

Memory Board (OLRA)

Two Mbyte

NOTES:

The OL810 LED page printer contains 1 megabyte of RAM, standard.

Two optional memory boards can be installed at the same time in the OL810.

Standard Memory (1 Mbyte)	Optional OLRA-2 (1 Mbyte)	Optional OLRA-2 (1 Mbyte)	Optional OLRA (2 Mbyte)	Optional OLRA (2 Mbyte)	Total Memory
Installed					1 Mbyte
Installed	Installed				2 Mbyte
Installed	Installed	Installed			3 Mbyte
Installed			Installed		3 Mbyte
Installed	Installed		Installed		4 Mbyte
Installed			Installed	Installed	5 Mbyte

1.10.02 Font ROM Card

NOTE:

Two cards can be installed at the same time

Tax

Prestige Elite

Letter Gothic

1.10.03 Paper Trays

Letter (200 sheet capacity)

Legal (200 sheet capacity)

Envelope (15 capacity)

Executive (200 sheet capacity)

A4 (200 sheet capacity)

Universal (200 sheet capacity)

1.10.04 Serial Interface Board

RS-232C Serial

Provides serial communication capability at speeds up to 19.2 Kbits per second.

1.10.05 Second Paper Feed Mechanism

The second paper feed mechanism allows paper feeding from two paper trays. A second paper tray must be purchased for use with the second paper feed mechanism.

Copyright 1997, Okidata, Division of OKI America, Inc. All rights reserved. See the OKIDATA Business Partner Exchange (BPX) for any updates to this material. (<http://bpx.okidata.com>)

1.11 RELIABILITY

1.11.01 Mean Page Between Failure (MPBF)

Approximately 32,000 pages

1.11.02 Mean Time To Repair (MTTR)

Approximately 20 minutes

1.11.03 Printer Life

Approximately 300,000 pages

1.11.04 LED Printhead Life

Built to exceed printer life

1.11.05 Fuser Life

Approximately 180,000 pages

1.11.06 Printer Duty Cycle

Approximately 12,000 pages per month @ 5% print density

1.11.07 Toner Life

Approximately 2,500 pages at approximately 5% density

1.11.08 Image Drum Life

Approximately 15,000 pages

1.11.09 Warranty

One year, parts and labor (entire printer)

Five years, LED printhead

1.11.10 Service

Authorized Okidata Service Centers

2.1 PRODUCT OVERVIEW

2.1.01 General Information

This section describes the operation of the printer. The information is divided into these four sections.

Control Unit (CU)

Printer Unit (PU)

Mechanical Operation

Sensors and Switches

Copyright 1997, Okidata, Division of OKI America, Inc. All rights reserved. See the OKIDATA Business Partner Exchange (BPX) for any updates to this material. (<http://bpx.okidata.com>)

2.1.02 Control Unit (CU)

The control unit regulates the reception of data from the host system interface. After receiving data and commands from the host system, the CU generates bit image data. The CU transfers data and commands to the Printer Unit (PU).

The following are the principal hardware components of the CU.

Main Control Board
Serial Interface Board (Option)
Memory Boards (Options)
Font Cards (Options)

Copyright 1997, Okidata, Division of OKI America, Inc. All rights reserved. See the OKIDATA Business Partner Exchange (BPX) for any updates to this material. (<http://bpx.okidata.com>)



Service Guide OL810

Chapter 2 Principles of Operation

Block Diagram: Control Unit

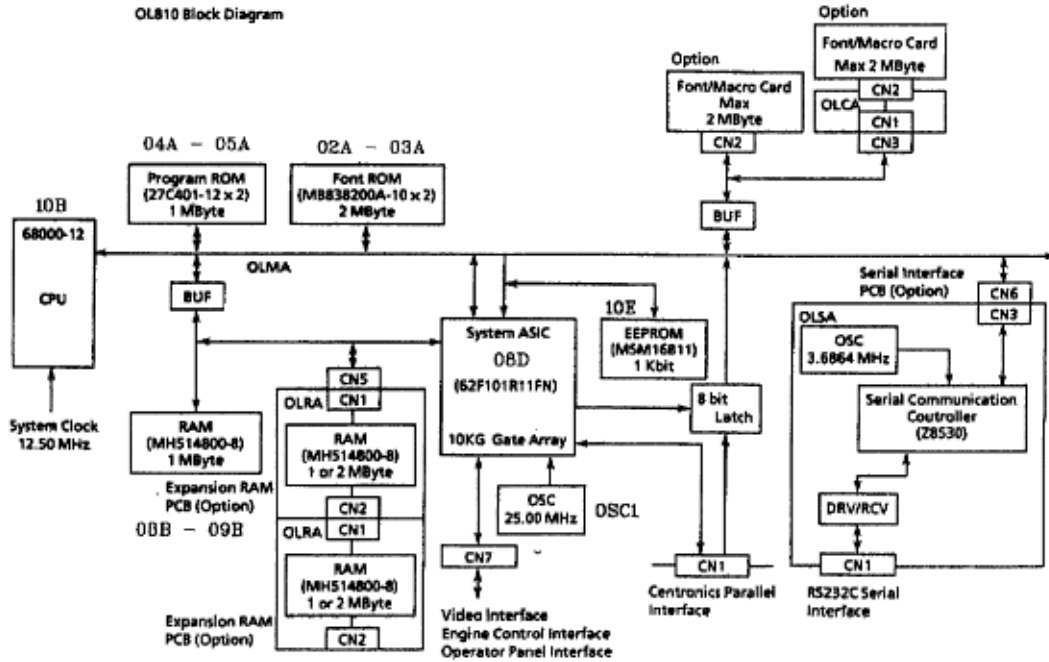

Copyright 1997, Okidata, Division of OKI America, Inc. All rights reserved. See the OKIDATA Business Partner Exchange (BPX) for any updates to this material. (<http://bpx.okidata.com>)

Main Control Board (OLMA)

The main control board consists of a 25 Mhz oscillator, a Motorola 68000 Microprocessor (CPU), two 1 Mbyte Font ROMs, a 1 Mbyte Program ROM, 1 Mbyte of RAM, an EEPROM, and a Gate Array. The main control board is connected to the host system through a Centronics parallel interface or an optional RS-232C serial interface. The main control board is connected to the printer unit via CN7 on the main control board and J7 on the PUs engine controller board.

The Gate Array is housed in a LSI. This component can read/write/ process data simultaneously in accordance with the 25Mhz clock pulse. Data is read from and written to the EEPROM via the gate array. The gate array also provides the dynamic RAM refresh. The gate array sends a 12.5 Mhz clock signal to the microprocessor. This clock pulse governs the processing and executing of commands by the CPU. The EEPROM, located on the main control board, stores the default interface protocol information. The gate array controls reading data from, and writing data to, the dynamic RAM.

There are six major functions of the main control board.

- Reception Control
- Command Analysis Processing
- Font Processing
- Raster Buffer Read Operation
- Engine Interface (I/F) Processing
- Operation Panel Control

Copyright 1997, Okidata, Division of OKI America, Inc. All rights reserved. See the OKIDATA Business Partner Exchange (BPX) for any updates to this material. (<http://bpx.okidata.com>)



Reception Control

I-PRIME: Enable/Disable of the parallel interface port can be specified through the menu.
The RS-232C serial interface baud rate, parity, and busy control protocol are selected through the menu.

Copyright 1997, Okidata, Division of OKI America, Inc. All rights reserved. See the OKIDATA Business Partner Exchange (BPX) for any updates to this material. (<http://bpx.okidata.com>)

Command Analysis Processing

The printer has two emulation modes.

IBM Proprinter III XL: IBM

Laser Jet Series III: Hewlett Packard

Copyright 1997, Okidata, Division of OKI America, Inc. All rights reserved. See the OKIDATA Business Partner Exchange (BPX) for any updates to this material. (<http://bpx.okidata.com>)



Service Guide OL810

Chapter 2 Principles of Operation

Font Processing

Bit mapped fonts and the scalable fonts are available for Hewlett Packard LaserJet Series III emulation. Only the bit mapped fonts are available for IBM Proprinter III XL.

Copyright 1997, Okidata, Division of OKI America, Inc. All rights reserved. See the OKIDATA Business Partner Exchange (BPX) for any updates to this material. (<http://bpx.okidata.com>)

Raster Buffer Read Operation

Bit images written in the raster buffer are converted to serial data. The contents of the registers are transferred to the engine controller board.

Copyright 1997, Okidata, Division of OKI America, Inc. All rights reserved. See the OKIDATA Business Partner Exchange (BPX) for any updates to this material. (<http://bpx.okidata.com>)



Service Guide OL810

Chapter 2 Principles of Operation

Engine Interface (I/F)

The engine interface provides a control signal which governs the operation of the engine controller board when printing is requested.

Copyright 1997, Okidata, Division of OKI America, Inc. All rights reserved. See the OKIDATA Business Partner Exchange (BPX) for any updates to this material. (<http://bpx.okidata.com>)



Service Guide OL810

Chapter 2 Principles of Operation

Memory Boards OLRA and OLRA-2 (Options)

The printer contains 1 megabyte of RAM, standard. Two optional memory boards are available. Installing these boards increases the amount of available RAM. The OLRA memory board increases available RAM by 2 megabytes. The OLRA-2 memory board increases available RAM by 1 megabyte. Two optional memory boards can be installed at the same time in the printer.

The CPU detects the extended RAM board by sending the MEMEXIST signal. The RAMs capacity is identified during the power-on sequence. The end user can verify RAM capacity by printing the menu.

NOTES:

Total installed RAM cannot exceed 5 Mbyte

Two optional memory boards can be installed at the same time in the printer.

Standard Memory (1 Mbyte)	Optional OLRA-2 (1 Mbyte)	Optional OLRA-2 (1 Mbyte)	Optional OLRA (2 Mbyte)	Optional OLRA (2 Mbyte)	Total Memory
Installed					1 Mbyte
Installed	Installed				2 Mbyte
Installed	Installed	Installed			3 Mbyte
Installed			Installed		3 Mbyte
Installed	Installed		Installed		4 Mbyte
Installed			Installed	Installed	5 Mbyte

Font Card (Option)

Two optional font cards (for additional bit mapped/scalable fonts) can be installed at the same time. The printer must be OFF-LINE (the READY lamp is off) before the card can be inserted or removed. If the font card is inserted or removed while the printer is ON-LINE (the READY lamp is on), a CARD REMOVED ON-LINE error message will appear on the operator panel display.

Copyright 1997, Okidata, Division of OKI America, Inc. All rights reserved. See the OKIDATA Business Partner Exchange (BPX) for any updates to this material. (<http://bpx.okidata.com>)

2.1.03 Printer Unit (PU)

The principal hardware components of the printer unit are listed below.

- Engine Controller Board
- Power Supply Unit
- Fuser Unit
- Main Motor
- LED Array
- Registration Motor
- DC Fan
- Operation Panel
- Second Paper Tray Mechanism (Option)
- Image Drum Cartridge
- Sensors and Switches
- Toner End Sensor
- Inlet Sensor
- Outlet Sensor
- Paper Out Sensor
- Paper Tray Identification Switch
- Cover Open Switch

Block Diagram: Printer Unit

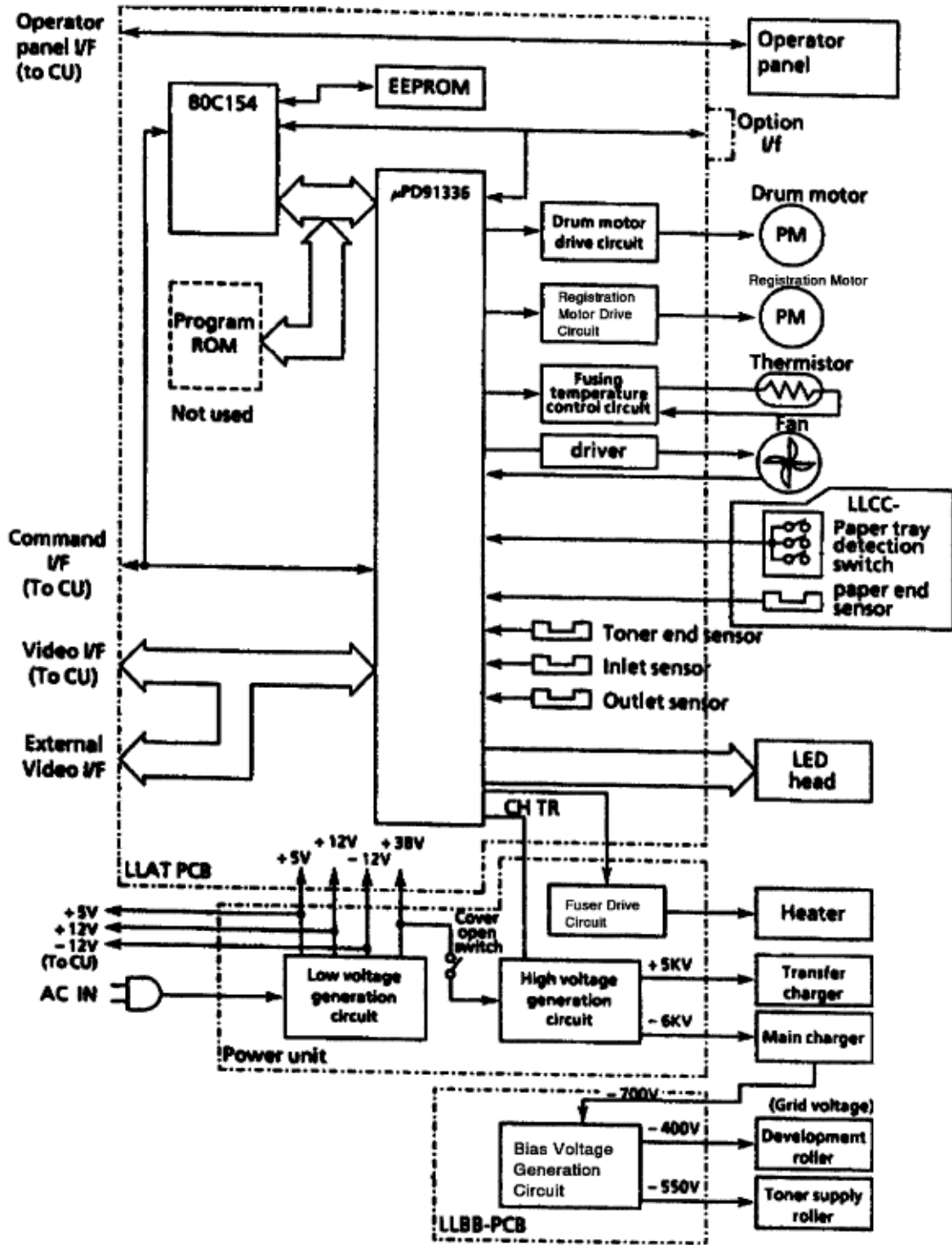

Copyright 1997, Okidata, Division of OKI America, Inc. All rights reserved. See the OKIDATA Business Partner Exchange (BPX) for any updates to this material. (<http://bpx.okidata.com>)

Engine Board Controller (LLAT)**Contents**

The PUs engine controller board contains the following items.

Eight Bit Microprocessor
128 Kbyte of internal RAM
32 I/O ports
5 interrupt lines
One Kbyte EEPROM
120 Pin LSI
36 I/O ports
Two Drivers
IC5
IC8
Toner End Sensor
Inlet Sensor
Outlet Sensor
Comparator IC7
Latch IC4
Four Driver Transistors T21-T24
Two Oscillators OSC1/OSC2.

Operations

The engine controller board enables the fuser lamp.

It activates the preliminary print circuits.

Upon the completion of the preliminary print functions, the engine controller board enables the LED array in conformance with the signals and commands received from the main control board.

The LED array illuminates, leaving a latent image on the photosensitive drum.

The engine controller board also controls paper feed, paper transfer, and electrostatic printing processes.

EEPROM Operation

The 128 Byte Electrically Erasable PROM (EEPROM) is loaded with the data listed below.

Total number of sheets printed after installation

Modified page count

Total number of sheets printed with the current drum

Total number of sheets printed with the current fuser

Setting of time required from the completion of printing to Quiet Mode

Feed time needed to feed the paper to a printable position

Vertical registration

LED array drive time

The data stored in the EEPROM can be accessed by using SW1 on the engine controller board to place the printer in the Maintenance Mode (See Section 3 of the Service Handbook).

The count of the total number of sheets printed with the drum currently in use should be taken as a rough measure of the useful life of the drum. The drum counter can be set to zero after the drum is replaced by holding down the RESET button and turning the power switch ON.

Power Supply Unit

The power supply unit generates the voltages listed below from the AC input voltage.

Voltage	Purpose
+ 5 vdc	Logic Levels
+ 12 vdc	Interface Line Voltage
- 12 vdc	Interface Line Voltage
+ 38 vdc	Motor/Fan Drive Voltage: High Voltage Source
+ 5 Kvdc	Transfer Charge Voltage
- 6 Kvdc	Drum Charge Voltage
- 700 vdc	Charge Grid Bias Voltage
- 550, - 400 vdc	Developer Bias Voltages

High Voltage / Bias Voltage Circuits

The high voltage circuit supplies the following voltages.

- The drum charge voltage (about - 6 Kvdc) to the charge wire.
- The transfer charge voltage (about + 5 Kvdc) to the transfer wire.

These two charge voltages are generated by a high voltage power supply unit, which is attached to the power supply unit.

The bias voltage circuit provides the grid voltage (about - 700 vdc) and developer bias voltages (about - 550 vdc and - 400 vdc).

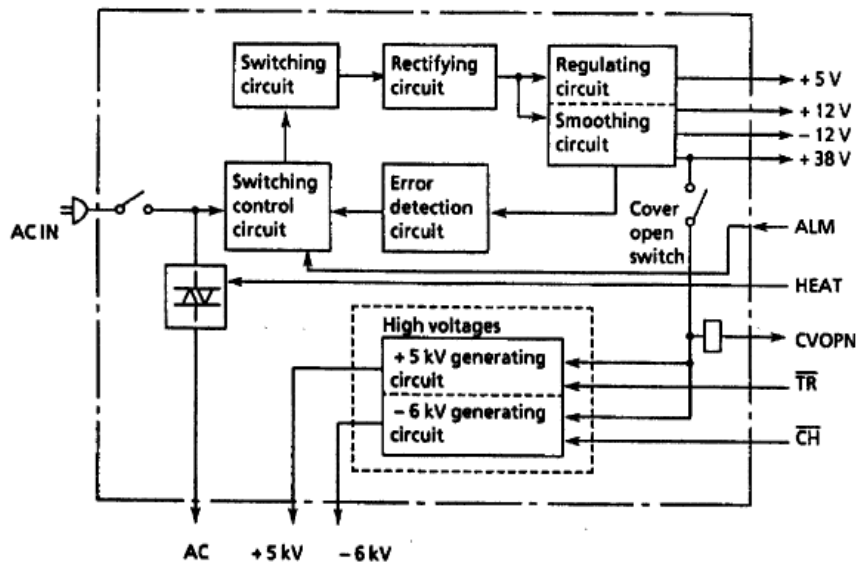

Fuser Unit

The fuser unit temperature is maintained at approximately 180 degrees Celsius by a thermistor, a comparator, an LSI, and the CPU. A thermal fuse, located within the fuser unit, prevents abnormal temperature rises should the temperature control circuits fail.

NOTE:

The CPU checks for an open circuit in the thermistor at POWER-ON, setting a fuser alarm if this error is detected.

The CPU also sets a fuser alarm if the proper temperature is not attained within a specified period of time after power-on.

Upon detecting a fuser alarm, the CPU will halt (after printing the current page).

Copyright 1997, Okidata, Division of OKI America, Inc. All rights reserved. See the OKIDATA Business Partner Exchange (BPX) for any updates to this material. (<http://bpx.okidata.com>)

Main Motor (Drum Motor)

The main motor is driven by the motor drivers IC5 and IC8 (M54646). The main motor is a two-phase dc motor, driven by the DM-PH0,1 signals supplied by the LSI. T1 and T2 provide the internal switching frequency needed for proper phasing.

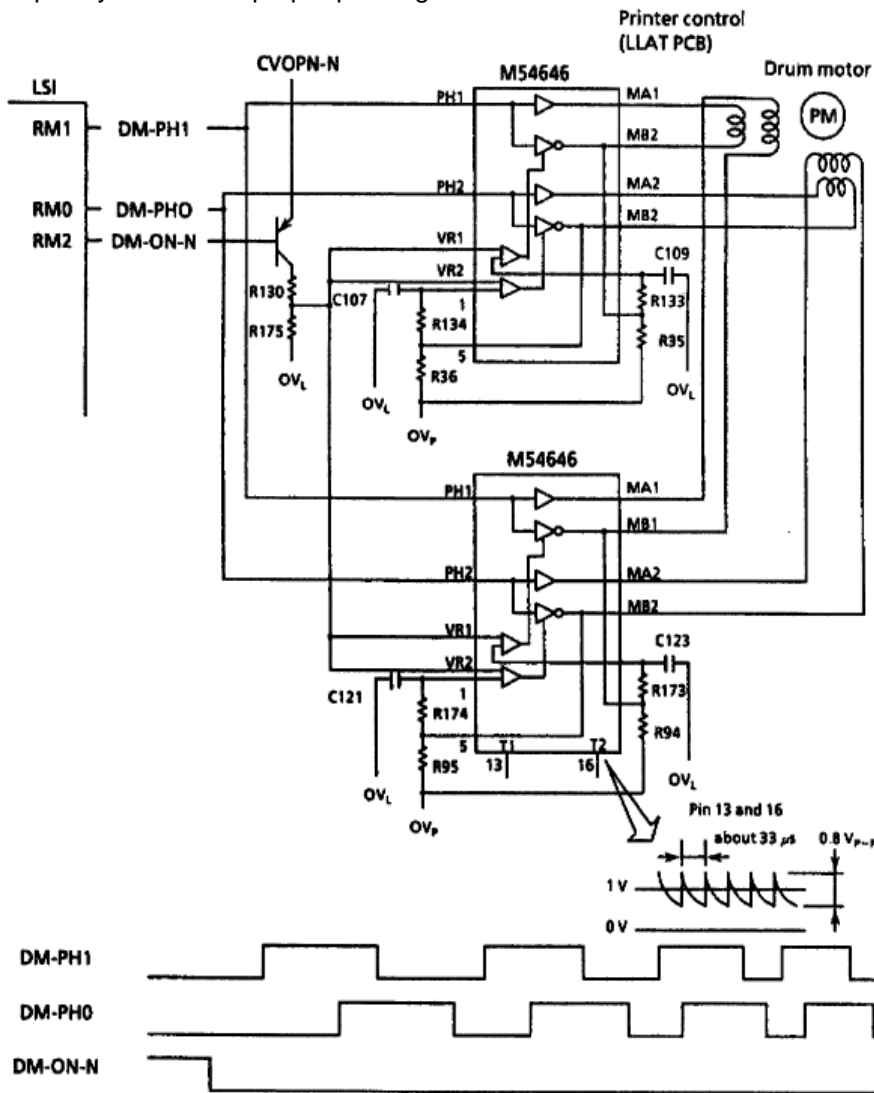

LED Array

Data on the 2,560 LEDs is loaded into the shift register by the head clock signal (HD CLK). The data is loaded into the latch circuit by the load head signal (HD LD). The on/off states of the LEDs are controlled by the signals (STB1-STB4). The logic gates in the latch circuits determine the on/off time of the LEDs. The LEDs on/off time is a function of the HD CLK, HD LD, HD DATA signals.

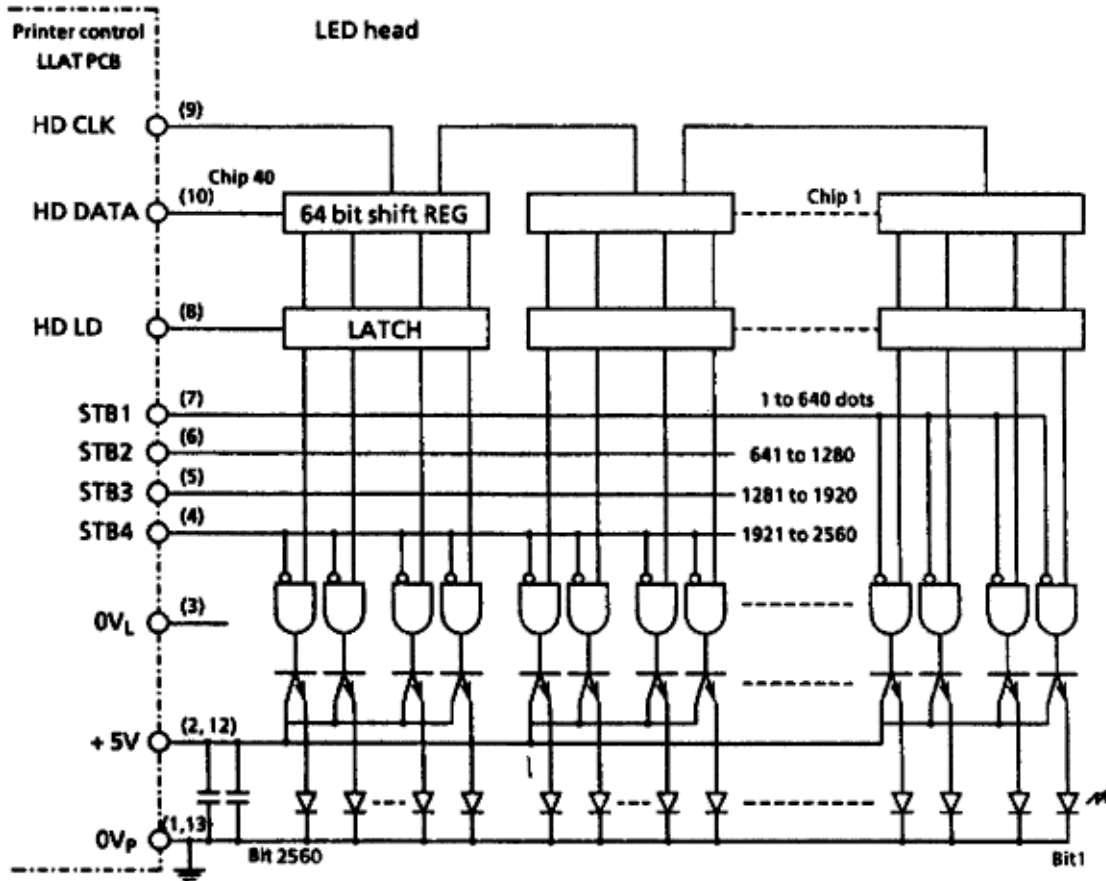

Registration Motor

The registration motor is a four-phase dc motor. It is driven clockwise (hopping), then counterclockwise (paper feed) by transistors TR-21,22,23,24.

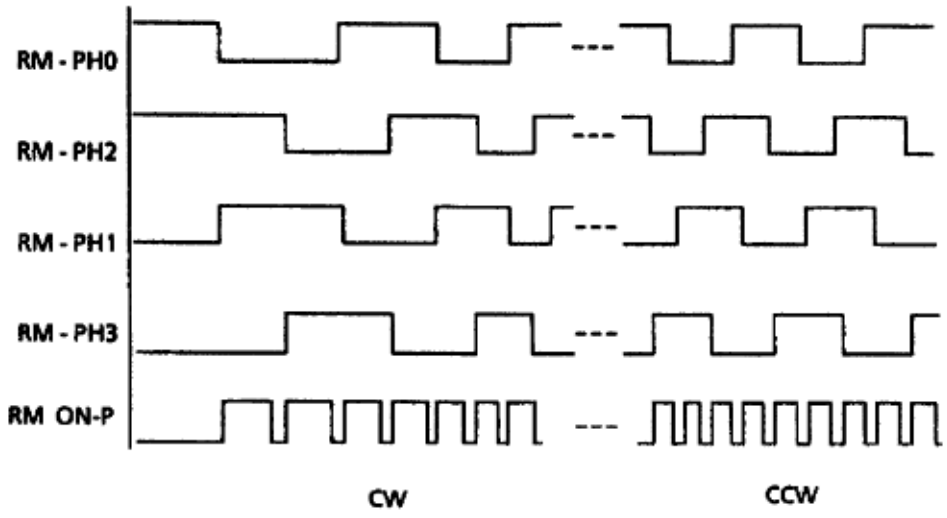
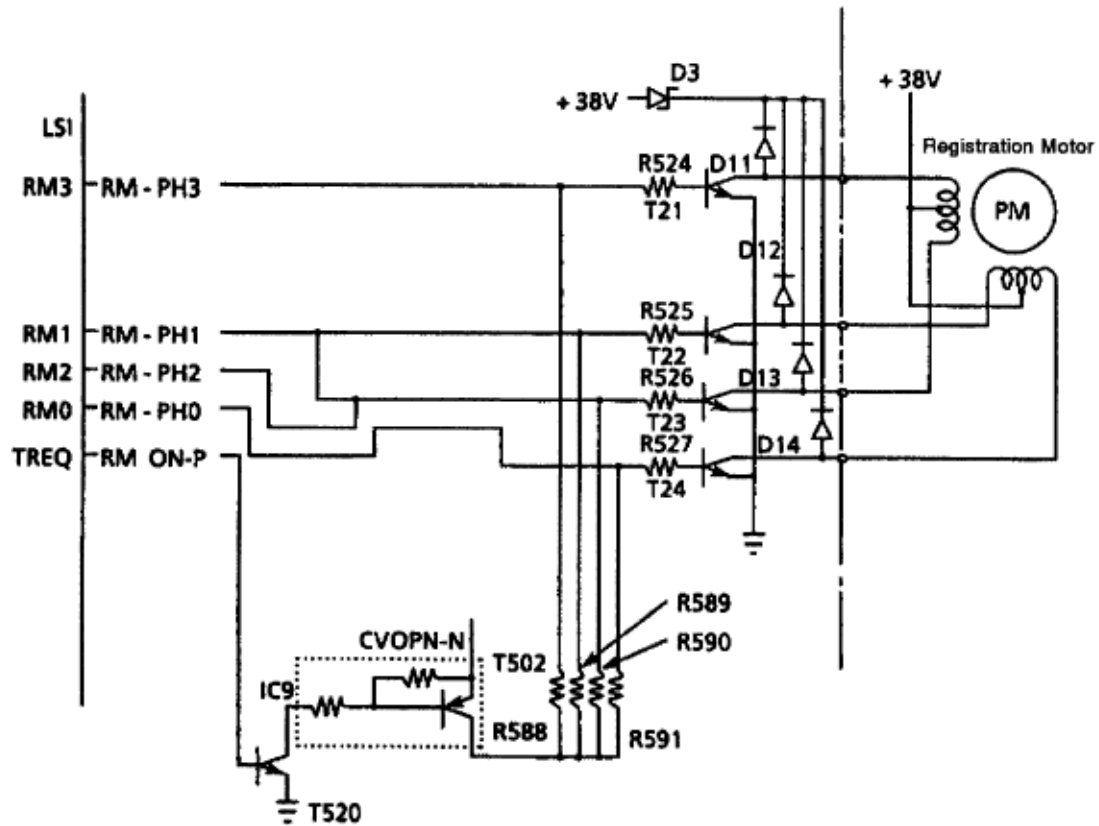

Copyright 1997, Okidata, Division of OKI America, Inc. All rights reserved. See the OKIDATA Business Partner Exchange (BPX) for any updates to this material. (<http://bpx.okidata.com>)

DC Fan

The +38vdc fan is controlled by the FAN ON-P signal from the LSI.

The fuser and the fan are NOT enabled when the cover is open.

If the fan fails to run, the fuser will turn off and **ERROR PU FAN MOTOR** (Fan Alarm) is displayed on the operator panel. Printing will be disabled.

In accordance with the TIME TO QUIET setting of the Level 2 Menu, the fuser will maintain the proper fusing temperature for 1 or 8 minutes after the last page has been printed.

If printing is not requested within the selected time frame, the fuser will turn OFF and the fan speed will be reduced 50%.

Selecting DISABLE allows the fuser to maintain the proper fusing temperature continuously.

Operation Panel

The following components make up the operation panel.

- 4-bit MPU
- LCD Control Driver
- LCD Display
- 16 characters x two lines
- Operation Panel Sheet
- LEDs
- Operation Buttons

The operation panel is connected to the main control board via the engine connection board and engine controller board. The operation panel is controlled by the main control board by the operation panel interface (I/F) signal.

The LCD control driver converts 4-bit character codes received from the main control boards CPU into 8-bit character codes. The control driver then retrieves the character pattern data (font) associated with the 8-bit character codes from the internal character generator (located on the operation panel board) for display on the LCD.

Copyright 1997, Okidata, Division of OKI America, Inc. All rights reserved. See the OKIDATA Business Partner Exchange (BPX) for any updates to this material. (<http://bpx.okidata.com>)

Second Paper Tray Mechanism

The optional second paper tray mechanism is controlled by the second tray driver board (LLFC). This board is attached to the left side of the second paper tray mechanism. The registration motor and paper tray detection sensors are mounted on this board.

Copyright 1997, Okidata, Division of OKI America, Inc. All rights reserved. See the OKIDATA Business Partner Exchange (BPX) for any updates to this material. (<http://bpx.okidata.com>)

2.1.04 Sensors and Switches

- Inlet Sensor (Photosensor)
- Outlet Sensor (Photosensor)
- Paper Tray Identification Switches
- Paper End Sensor (Photosensor)
- Cover Open Switch

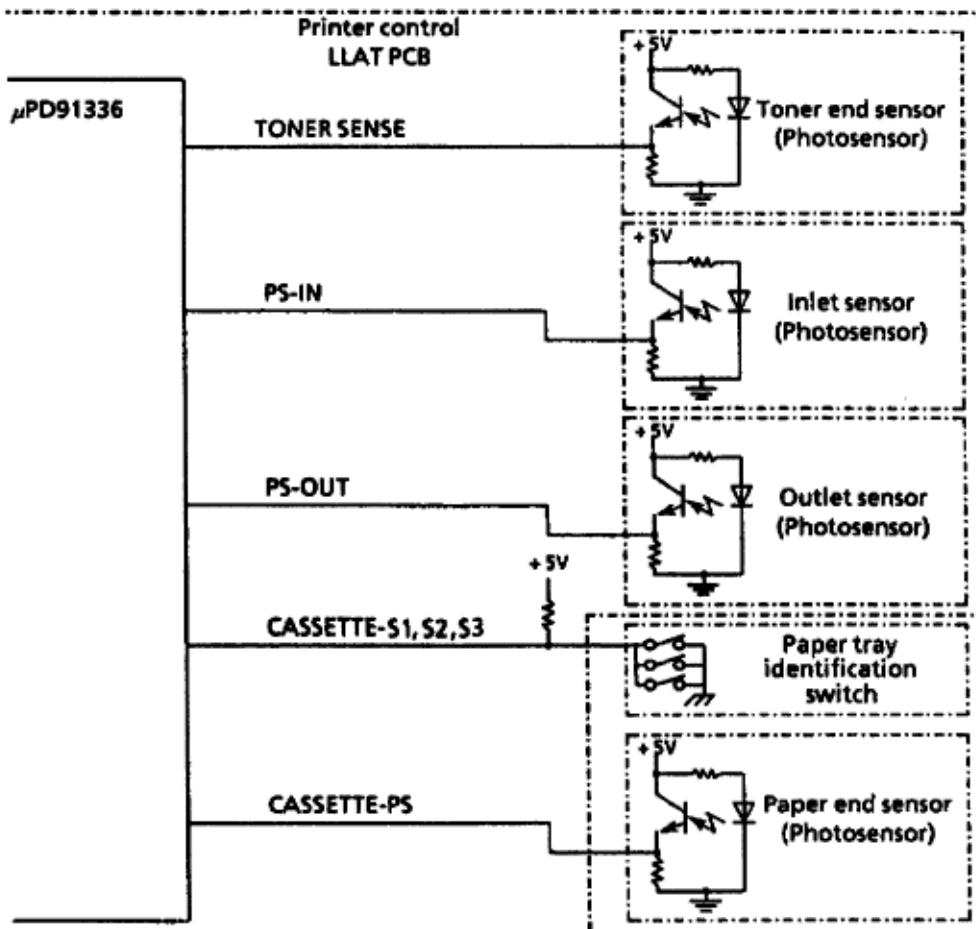

Sensor Functions

Power-On

The inlet and outlet sensors are checked for their on and off states at power on time.

Inlet sensor on: **PAPER FEED JAM ERROR** (Paper supply jam)

Outlet sensor on: **PAPER JAM ERROR** (Paper exit jam)

The thermistor sensor circuit detects if the temperature of the fusing unit reaches the normal temperature within the specified time. If it does not reach the normal temperature within the specified time, the thermistor sensor turns OFF the fuser and generates an alarm.

Hopping

Whenever the inlet sensor fails to detect paper within a predetermined period of time after a feed command has been issued to the paper supply system (tray), the failure is counted. A hopping operation is then attempted up to three times, and if the paper still fails to feed properly, a paper feed jam error occurs.

Feeding

If the leading part of the paper does not reach the outlet sensor within a predetermined period of time after the start of feeding by the registration motor, a paper jam error occurs.

Form Length Error Detection

Form length detection is not enabled for manually inserted paper or envelopes. Any form length, other than those specified in Section 1 of the Service Handbook, will generate a form length error, causing an error message to be displayed on the operator panel. To detect the form length, the processor times the interval between the activation and deactivation of the inlet sensor. The inlet sensor is deactivated after the registration motor starts in the forward direction.

Outlet Jam Detection

Since paper is fed through the printer at a fixed speed, the outlet sensor must remain on for a predetermined time. If the outlet sensor remains on longer, the controller assumes that an exit jam has occurred and an alarm is generated.

Copyright 1997, Okidata, Division of OKI America, Inc. All rights reserved. See the OKIDATA Business Partner Exchange (BPX) for any updates to this material. (<http://bpx.okidata.com>)

2.2 PRODUCT OPERATION

2.2.01 Electrostatic Printing

Functional Description

A - 700 vdc charge is placed on the photoconductive drum by supplying -6 Kvdc from the power supply to the charge wire. The printer turns on the LED array in conformance with the data received from the CUs main control board. Once the charged drum is exposed to this light, an electrostatic image is formed on the drum surface. This latent image is developed with toner. The toner image is then transferred and fused to the paper.

The electrostatic technology used in this printer is similar to that embodied in copying machines. The technology uses the processes described in the following sections.

Diagram: Electrostatic Printing

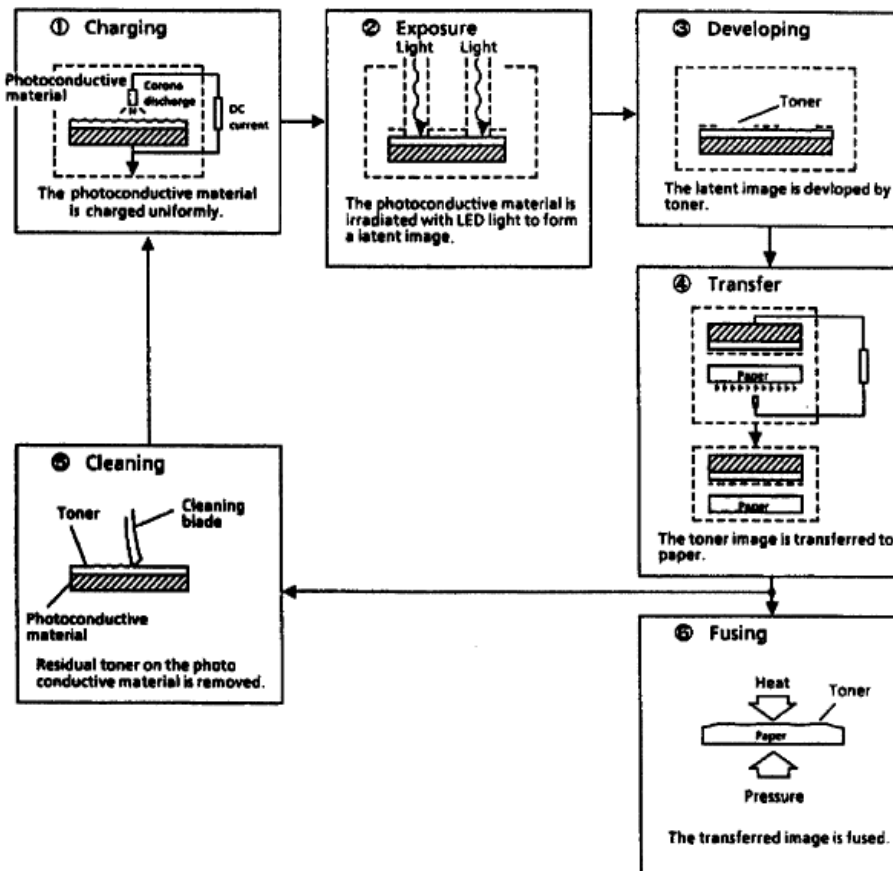

Copyright 1997, Okidata, Division of OKI America, Inc. All rights reserved. See the OKIDATA Business Partner Exchange (BPX) for any updates to this material. (<http://bpx.okidata.com>)

Diagram: Printing Process

Here is an illustration of the printing process. The white arrows show the rotation of the image drum. The black arrows show the paper feed path.

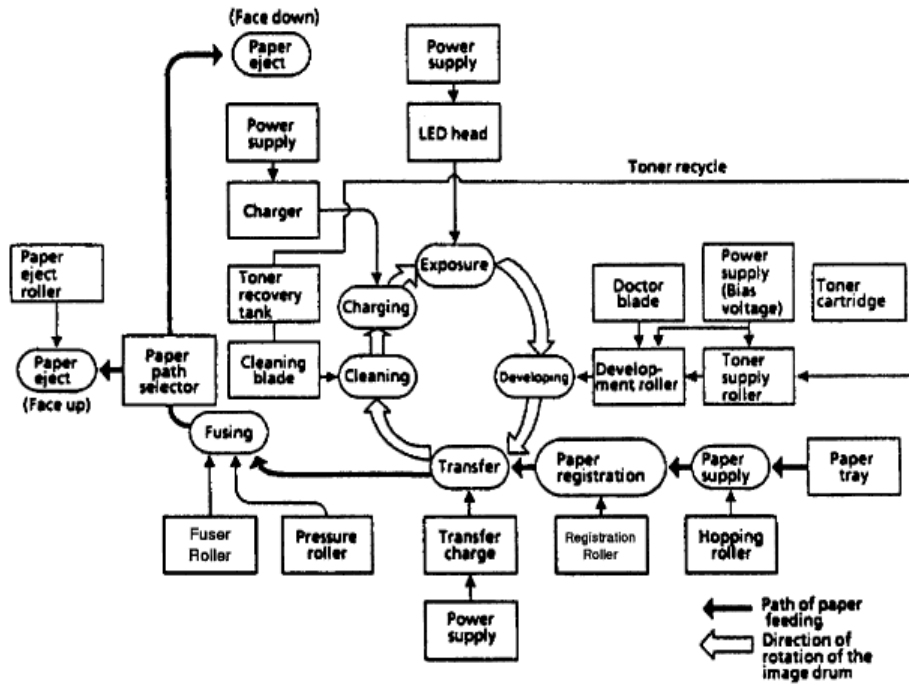

Processes

Hopping and Feeding

Hopping and feeding are accomplished by the registration motor, hopping roller, and registration rollers.

Turning the registration motor in the clockwise direction drives the hopping roller.

Turning the registration motor in the counter-clockwise direction drives the registration rollers.

Hopping

Hopping loads paper from the tray

The registration motor turns the hopping roller to advance the paper until the inlet sensor is enabled.

After the paper has enabled the inlet sensor, the hopping roller continues to advance the paper a predetermined distance. The paper contacts the registration roller. The registration roller, along with the free-spinning upper metal pressure roller, removes paper skew.

Feeding

At the end of the hopping process, the registration motor reverses direction and the registration rollers transport the paper through the printer.

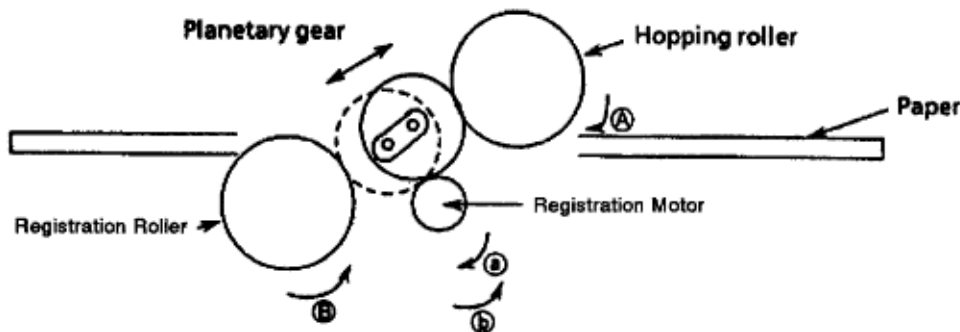

Charging

The surface of the photoconductive drum is uniformly charged.

-6 Kvdc is applied to the charge wire. This causes negative ions to be generated in the vicinity of the charge wire (corona discharge). The negative ions are discharged to the grid plate and the image drum surface. Since the drum surface is not conductive (in the dark), the negative charge (approximately -700 vdc) remains on the drum. To ensure that the drum surface is not charged with more than -700 vdc, a varistor is connected between the grid and ground. If the grid voltage exceeds -700 vdc, the varistor shunts this excess voltage to ground.

Exposure

The charged photoconductive drum is exposed to light, forming an electrostatic image associated with the print image on the drum.

Light emitted from the LED array strikes the image drum surface, which is charged with negative ions. The areas of the drum struck by light become conductive. This causes the surface potential in these areas to drop (from -700 vdc to approximately -100 vdc). This forms a latent image on the image drum.

Developing

Negatively charged toner is attracted to the latent image, making the image visible.

The toner supply roller is constructed of a porous material which absorbs toner. The toner supply roller contains a -550 vdc bias charge and the development roller contains a -400 vdc bias charge. Since the development roller charge is more positive than the toner supply roller charge, toner is transferred from the toner supply roller to the development roller.

The toner on the development roller is leveled by the doctor blade. This forms a thin coat of toner on the development roller surface.

Since the areas of the drum exposed to light are charged more positively (-100 vdc) than the toner (-400 vdc), toner is attracted to the exposed areas, making the latent image visible.

Transfer

The toner is attracted to positive charged paper.

As paper passes under the image drum surface, a positive charge (+5 Kvdc), is applied to the transfer charge wire. This causes the paper to acquire a positive charge through corona discharge. Since the papers charge (+5 Kvdc) is more positive than the toner charge (-100 vdc), the toner is transferred to the paper.

Cleaning

Residual toner is removed from the image drum surface.

Upon completion of transfer, residual toner on the image drum is scraped off by the cleaning blade and collected in the toner recovery unit.

Fusing

The toner image is fused to the paper using heat and pressure.

The toner image is fused on the paper by placing it between the heat roller and the pressure (back-up) roller. The heat roller is teflon coated and contains a 400 watt quartz lamp. A thermistor regulates the heat roller temperature at a predetermined temperature (about 150° C). A thermostat removes the supply voltage to the heat roller in the event of an abnormal temperature rise. The pressure (back-up) roller springs produce a pressure of 6.5 pounds on the paper.

Paper Ejection

Paper is transported from the fuser unit by the pressure (back-up) roller. If the face-up stacker is closed, paper is routed to the top of the printer for face-down delivery.

Toner Recycling

Unused toner collected during cleaning is returned to the developer unit.

Toner in the toner recovery tank is moved to the toner cartridge for reuse.

Copyright 1997, Okidata, Division of OKI America, Inc. All rights reserved. See the OKIDATA Business Partner Exchange (BPX) for any updates to this material. (<http://bpx.okidata.com>)

3.1 MAINTENANCE

3.1.01 General Information

This section lists the parts replacement procedures, printer adjustments, and procedures for cleaning and lubrication.

Disassembly should not be performed unless absolutely necessary. **NEVER** perform disassembly on a malfunctioning printer until you have followed the failure analysis procedures in

Section Four of this Service Handbook.

Follow the procedures listed in *Adjustments and Service Settings*. Counters may have to be reset and adjustments may be required when either consumables or parts are replaced. Failure to perform these procedures could result in unnecessary service calls.

The printer is a xerographic device. Cleaning procedures must be performed correctly if high print quality is to be achieved.

Copyright 1997, Okidata, Division of OKI America, Inc. All rights reserved. See the OKIDATA Business Partner Exchange (BPX) for any updates to this material. (<http://bpx.okidata.com>)

3.1.02 Maintenance Items

The following tools are required to service the printer.

#2 Phillips Screwdriver (with magnetic tip)

Straight-slot Screwdriver

Digital Multimeter

Needle Nose Pliers (4 Inch)

Copyright 1997, Okidata, Division of OKI America, Inc. All rights reserved. See the OKIDATA Business Partner Exchange (BPX) for any updates to this material. (<http://bpx.okidata.com>)

3.1.03 Maintenance Precautions

1. Do not disassemble the printer if it is operating normally.
2. Before starting disassembly and assembly, always turn the AC power switch OFF and pull out the AC plug.
3. Detach the interface cable, if installed.
4. Do not remove parts unnecessarily: try to keep disassembly to a minimum.
5. Use the recommended maintenance tools.
6. When disassembling, follow the listed sequence. Failure to follow the correct sequence may result in damaged parts.
7. Since screws, collars and other small parts are easily lost, they should be temporarily attached to the original positions.
8. When handling circuit boards use extreme care. ICs such as microprocessors, ROM and RAM can be destroyed by static electricity.
9. Do not place printed circuit boards directly on conductive surfaces.
10. Follow the recommended procedures when replacing assemblies and units.
11. After replacing the drum cartridge, clear the drum counter by following the Drum Counter Reset Procedure in Section 3.3 of this Service Handbook.
12. After replacing the fusing unit, clear the fusing unit counter by following the Fuser Counter Reset Procedure in Section 3.3 of this Service Handbook.
13. After replacing the LED head, check to see if the LED Head Drive Time rating needs to be set. Use the Setting the LED Head Drive Time Procedure in Section 3.3 of this Service Handbook.

3.2 DISASSEMBLY/ASSEMBLY PROCEDURES

General Information

This section contains the printer disassembly procedures. Only the removal procedures are explained here. Reverse the procedure for the installation.

At the bottom of each procedure is a listing of Okidata part numbers, item descriptions, and cross-references to Appendix B. Items included in the Recommended Spare Parts List are marked RSPL. N/A will appear where a part number is not available.

We have listed disassembly procedures for major components of the printer. If you decide to perform disassembly during this training, we recommend that you perform **only** the disassembly procedures for RSPL items. All other procedures are provided to assist you in identifying parts. It is not likely that you will perform these procedures while servicing a printer.

This section has a flowchart of the disassembly procedures. An index for the flowchart is also provided.

Copyright 1997, Okidata, Division of OKI America, Inc. All rights reserved. See the OKIDATA Business Partner Exchange (BPX) for any updates to this material. (<http://bpx.okidata.com>)

3.2.01 Preliminary Items

1. Turn the power switch (1) OFF.
2. Detach the AC power cord (2) from printer.
3. Remove the paper tray (3).
4. Detach the interface cable (4).
5. Remove the font cards (5), if installed.
6. Press the OPEN switch (6) and raise the stacker cover (7).
7. Push the lock levers (8) toward the rear of the printer and open the LED holder (9).
8. Lift and remove the image drum cartridge (10). To protect the image drum cartridge, place it back in the styrofoam shipping package.

NOTES:

The image drum counter should be reset when a new image drum is installed. Refer to Section 3.3 of this Service Handbook for details.

Refer to Appendix B for paper tray and font card part numbers.

The image drum and the toner cartridge are available in the consumables kits listed below.

P/N 56609701 Cord: AC (120 V) RSPL B.2.02

P/N 56624301 Cord: AC (220 V) Option B.2.02 and 12

P/N 56624501 Cord: AC 240 V (OL Series) UK Option B.2.02 and 12

P/N 56106601 Image Drum Cartridge Consumable B.2.04

Includes an Image Drum and Ozone Filter

P/N 52104201 Toner Cartridge Kit Consumable B.2.16

Includes a Toner Cartridge, a Fuser Cleaner Pad, and an LED Lens Cleaner Pad

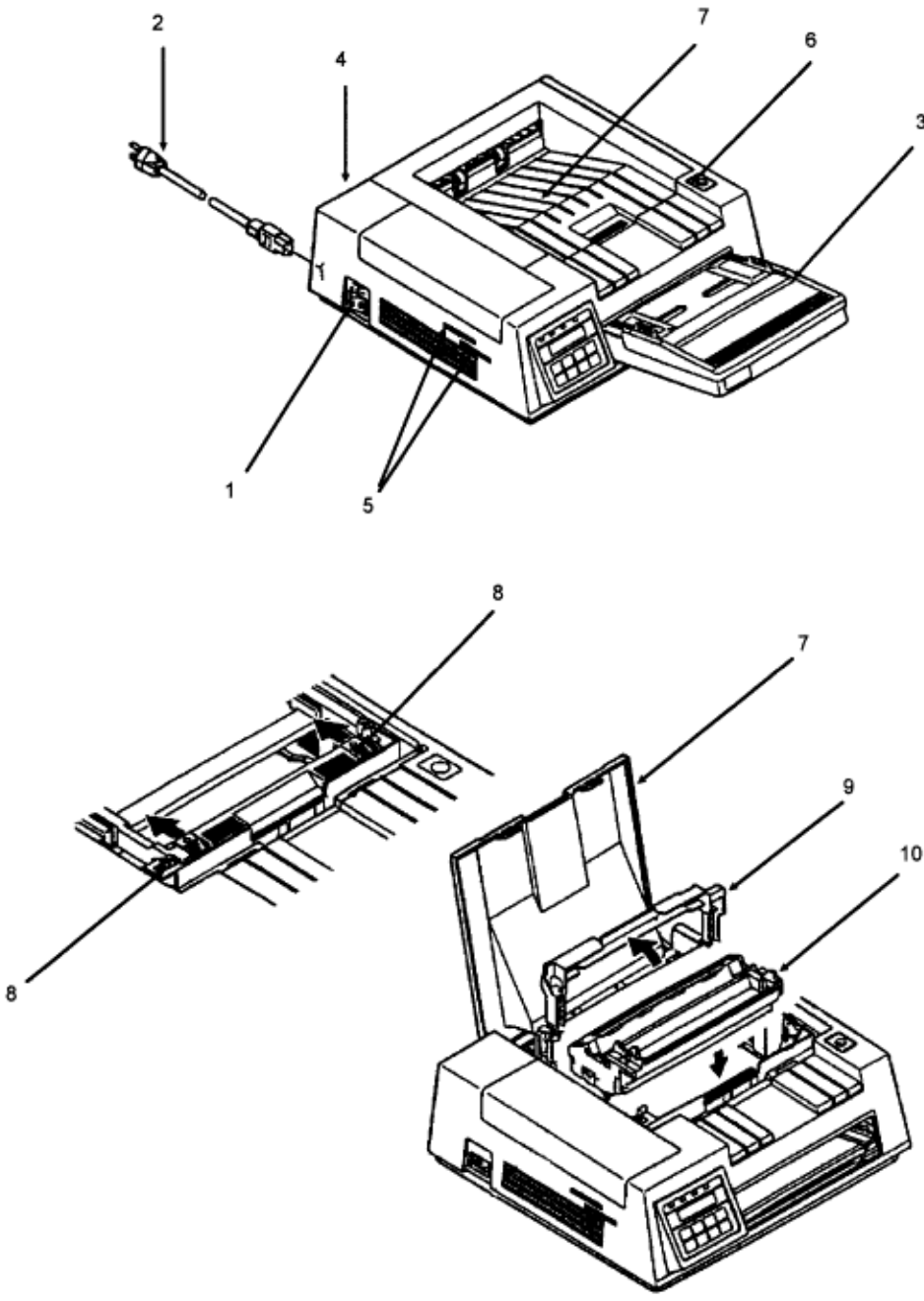

Copyright 1997, Okidata, Division of OKI America, Inc. All rights reserved. See the OKIDATA Business Partner Exchange (BPX) for any updates to this material. (<http://bpx.okidata.com>)

3.2.02 Upper Cover

1. Perform this procedure: 3.2.01.
2. Grasp the operator panel assembly (1) at its bottom and detach it.
3. Pull on the locking collar and then detach the connecting cable (2) from connector J1 (3) of the operator panel board (4).
4. Press the OPEN switch (5) and raise the stacker cover (6).
5. Remove the access cover (7).
6. Remove the two screws (8) and lift the front side of the upper cover (9).
7. Pivot the upper cover towards the rear and remove the upper cover.
8. Remove the stacker cover and two reset springs (10).
9. Remove the face-up stacker assembly (11).
10. The lower unit (12) contains the boards, shields, paper feed mechanism, transfer charger assembly and rollers.

Installation

11. Open the stacker cover.
12. Align the square slots of the upper cover with the claws of the lower cover. The claws are located on the back of the lower cover, at the left and right sides.
13. Lower the upper cover into position.

CAUTION:

When assembling the operator panel board, you must install the connecting cable with the blue strip to the left.

If the cover is not installed properly, paper jams will result.

P/N N/A Access Cover B.2.02

P/N 50066601 Stacker: Face-up Assembly RSPL B.2.02

P/N 50213508 Panel: Operator Assembly RSPL B.2.02

P/N 50213602 Unit: Lower RSPL B.2.02

P/N 50918001 Reset Spring B.2.02

P/N 53338203 Cover: Upper w/logo (OL810) RSPL B.2.02

P/N N/A Stacker Cover Assembly B.2.02

P/N 52046506 Logo: Plate OL810 RSPL B.2.02

P/N 52054004 Touch Sheet: Op Panel (OL810) RSPL B.2.02

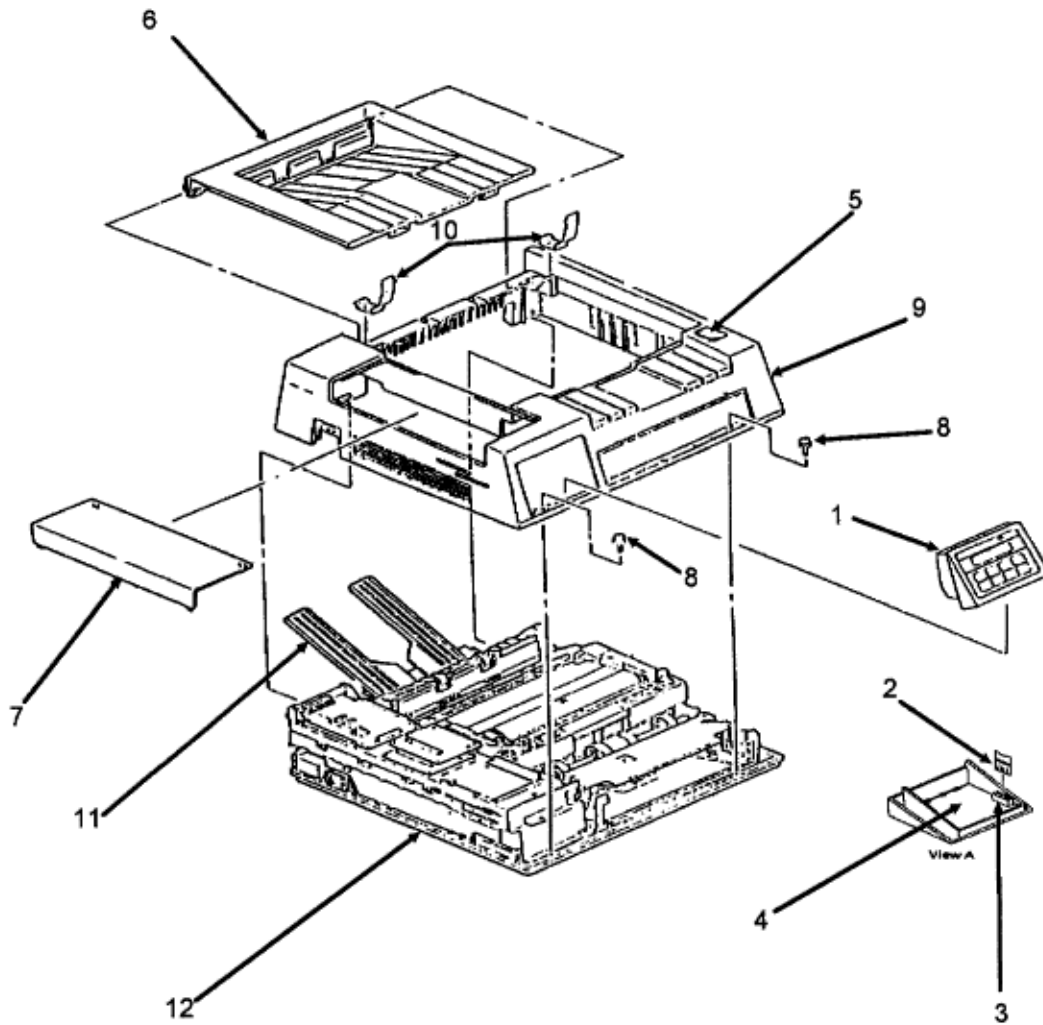

3.2.03 Stacker Open Switch Assembly

1. Perform these procedures: 3.2.01 and 3.2.02.
2. Turn the upper cover over and detach the spring (1).
3. Work the pins of the shaft (2) from the arms of the upper cover and remove the shaft.
4. Release the two claws and remove the metal plate and cover open switch (3).

NOTE:

The claws and metal plate are not shown.

P/N 50917901 Spring B.2.02

P/N 51111301 Shaft B.2.02

P/N 53527401 Button B.2.02

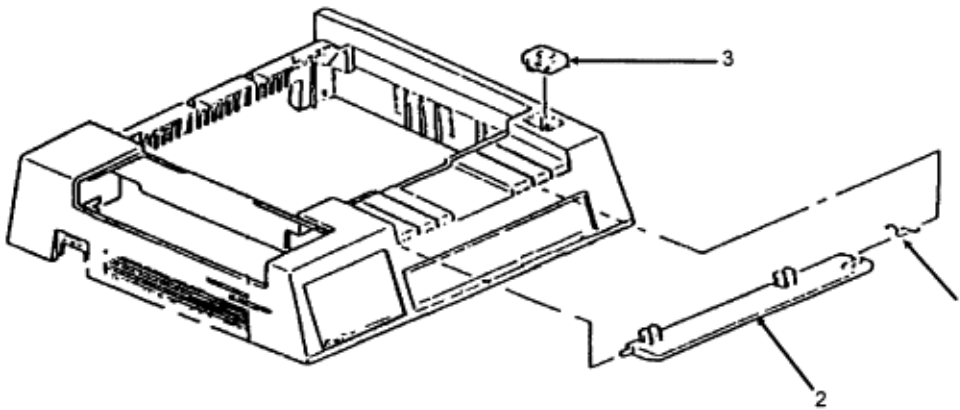



Service Guide OL810

Chapter 3 Maintenance

3.2.04 LED Head

1. Perform this procedure: 3.2.01.
2. Push the two blue lock levers (1) toward the rear of the printer and open the LED holder (2).
3. Squeeze the LED head (3) and the LED holder together. This eases the tension on the springs (4).
4. Use a screwdriver to remove the two clamps (5) on either side of the LED head.
5. Remove the LED head.
6. Remove the springs.

NOTES:

Avoid touching the LED array when squeezing the LED head.

Clean the LED array with the LED lens cleaner provided in the toner cartridge kit. Refer to Section 3.4 of this Service Handbook.

LED Head Replacement

When you replace one LED head with another, the LED head drive time may need to be reset. Refer to Section 3.3 of this Service Handbook for further information.

CAUTION:

The OL810 printhead should not be used in non-OST Okidata printers.

The barcoded intensity rating label on the upper left side of the LED head will tell you which LED head you are working with. A designation of 300T supports OST. A designation of 300S does not support OST.

When replacing the OL810 LED head, you must install an LED head with OST capability. If you install a standard (non-OST) LED head, the printer will not function properly. A "mirror image" of the desired data will print. The printer will print "mirror images", regardless of the Smoothing Setting in the Level 2 menu.

P/N 50914101 Spring: Bias (LED Head) RSPL B.2.06

P/N 50914301 Spring: Clamp (LED) RSPL B.2.06

P/N 55622301 Unit: LED Head (300 dpi OST) RSPL B.2.06

P/N 52104201 Toner Cartridge Kit Consumable B.2.16

Includes a Toner Cartridge, a Fuser Cleaner Pad, and an LED Lens Cleaner Pad

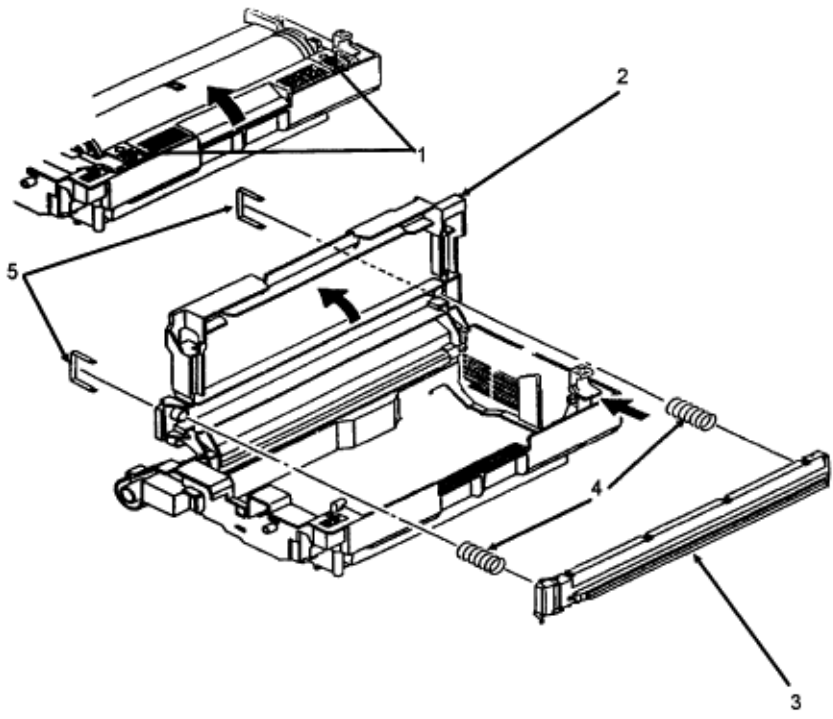

Copyright 1997, Okidata, Division of OKI America, Inc. All rights reserved. See the OKIDATA Business Partner Exchange (BPX) for any updates to this material. (<http://bpx.okidata.com>)

3.2.05 RS232 Interface Board (OLSA, Option)

1. Perform these procedures: 3.2.01 and 3.2.02.
2. Remove the two mounting screws (1).
3. Unlock the interface board (2) from shield plate B (3).
4. Disconnect the connector (4) as you lift and remove the interface board.

P/N 51008201 Plate: Shield B RSPL B.2.09

P/N 55067801 PCB: OLSA Serial I/F Option B.2.09 and 12

P/N 70021201 Serial Interface Kit Option B.2.12

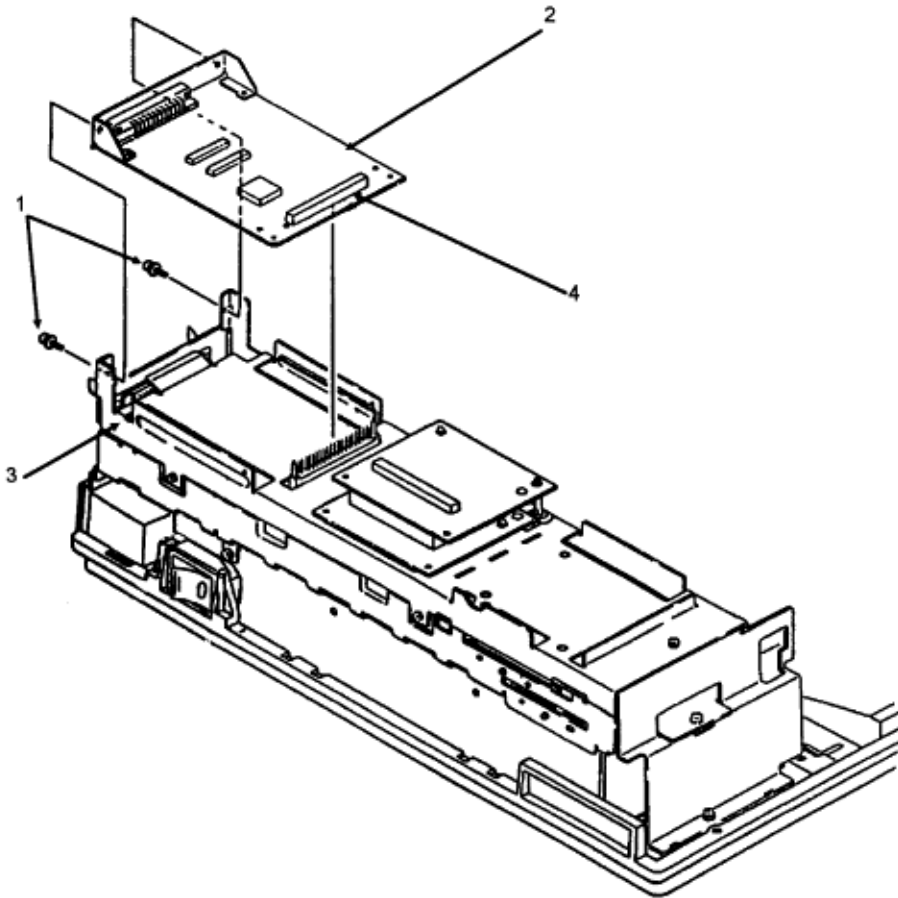

Copyright 1997, Okidata, Division of OKI America, Inc. All rights reserved. See the OKIDATA Business Partner Exchange (BPX) for any updates to this material. (<http://bpx.okidata.com>)



Service Guide OL810

Chapter 3 Maintenance

3.2.06 Memory Boards (OLRA-2 or OLRA, Options)

NOTE:

Two types of memory boards may be installed at the same time in the printer. Use the same procedure for each board.

Refer to Section 3.3 of this Service Handbook or the Printer Handbook for changing menu settings when the memory boards are installed.

Standard Memory (1 Mbyte)	Optional OLRA-2 (1 Mbyte)	Optional OLRA-2 (1 Mbyte)	Optional OLRA (2 Mbyte)	Optional OLRA (2 Mbyte)	Total Memory
Installed					1 Mbyte
Installed	Installed				2 Mbyte
Installed	Installed	Installed			3 Mbyte
Installed			Installed		3 Mbyte
Installed	Installed		Installed		4 Mbyte
Installed			Installed	Installed	5 Mbyte

Installed 1 Mbyte Installed 2 Mbyte Installed 3 Mbyte Installed 3 Mbyte Installed 4 Mbyte Installed 5 Mbyte

1. Perform these procedures: 3.2.01 and 3.2.02.
2. Press the OPEN switch and raise the stacker cover.
3. Remove the access cover.
4. Unlock the two circuit board supports (1).
5. Disengage the connector (2) as you remove the memory board (3).

P/N 55067901 PCB: OLRA Option B.2.09 and 12 2 Megabyte RAM

P/N 55067902 PCB: OLRA-2 Option B.2.09 and 12 1 Megabyte RAM

P/N 70021001 1 MB Memory Board Kit Option B.2.12

P/N 70021101 2 MB Memory Board Kit Option B.2.12

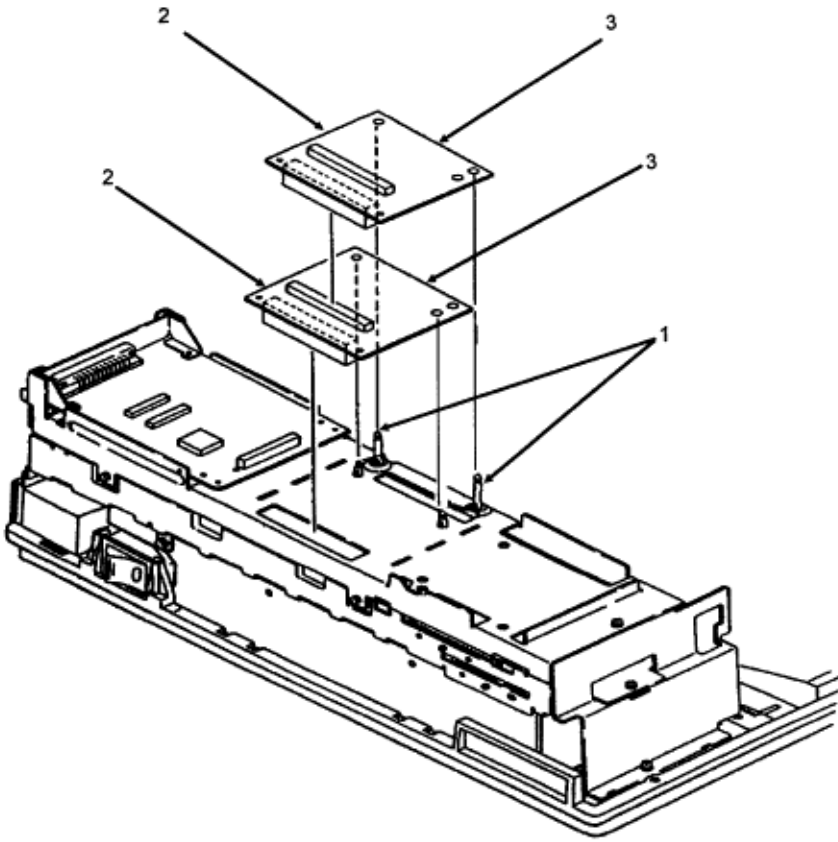

Copyright 1997, Okidata, Division of OKI America, Inc. All rights reserved. See the OKIDATA Business Partner Exchange (BPX) for any updates to this material. (<http://bpx.okidata.com>)

3.2.07 Main Controller Board (OLMA) and Second Font Card Board (OLCA)

1. Perform these procedures: 3.2.01, 3.2.02, 3.2.05, and 3.2.06.
2. Remove the four screws (1).
3. Remove shield B (2).
4. Remove the four screws (3).
5. Disconnect the connector (4) as you remove the main controller circuit board (5).
6. Remove the second font card circuit board (6).
7. Remove the two screws (7).
8. Remove the bracket (8) from the second font card circuit board.

P/N 51008401 Guide: Card (C) RSPL B.2.09

P/N 51708201 Bracket: Font Card Board RSPL B.2.09

P/N 55067601 PCB: OLMA Main RSPL B.2.09

P/N 55067701 PCB: OLCA 2nd Font Card RSPL B.2.09

P/N 55923901 IC: CU EEPROM RSPL B.2.09 MSM16811RS-NW

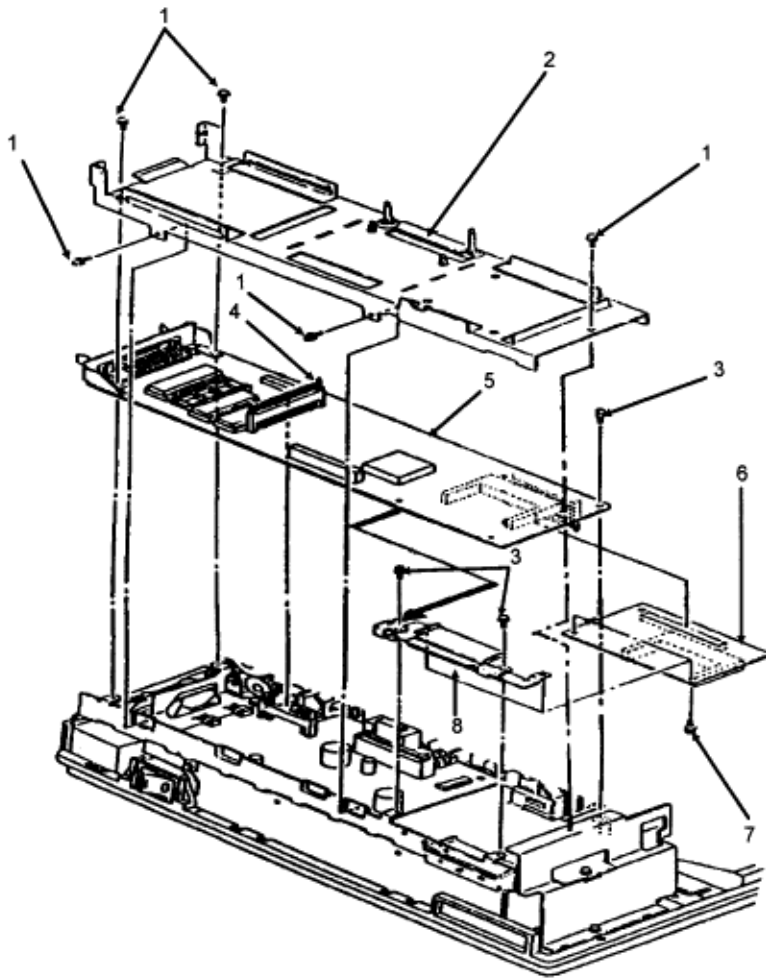

Copyright 1997, Okidata, Division of OKI America, Inc. All rights reserved. See the OKIDATA Business Partner Exchange (BPX) for any updates to this material. (<http://bpx.okidata.com>)

3.2.08 Engine Controller Board (LLAT)

1. Perform these procedures: 3.2.01, 3.2.02, 3.2.05, 3.2.06, and 3.2.07.
2. Disconnect the cables from the connectors J1 - DC fan (1), J2 - fuser thermistor (2), and J5 - paper supply unit (3).
3. Open the LED holder to allow access to the engine board mounting screw (4) and remove the mounting screw.
4. Close the LED holder and raise the upper unit.
5. Remove the three remaining mounting screws (5).
6. Lift the engine controller board (6) to disconnect it from the interconnect board (7).

CAUTION:

Be careful not to lose the plastic spacers (8) located between the shield frame and the engine controller board. When installing the engine controller board, be sure that the spacers are in place or the engine controller board will short against the shield frame. 7. On the engine controller board, press the pawls (9) to unlock and remove the print board cover (10).

Board Replacement

8. Remove EEPROM (Q2) (11). The program ROM is masked to the CPU.
9. Install the EEPROM and ROM on the new board.

Board Installation

10. Route the thermistor cable to J2 so it does not obstruct the movement of the outlet sensor.
11. Connect the paper supply unit cable to the engine controller circuit board via the groove in the shield plate.

P/N 50515801 Spacer: Board with 5 mm screw RSPL B.2.09

P/N 50515808 Spacer: Board with 18 mm screw RSPL B.2.09

P/N 53528401 Board Cover B.2.09

P/N 55067502 PCB: LLAT-2 Eng Controller RSPL B.2.09

P/N 55938201 IC: Eng EEPROM BR93LC46A RSPL B.2.09

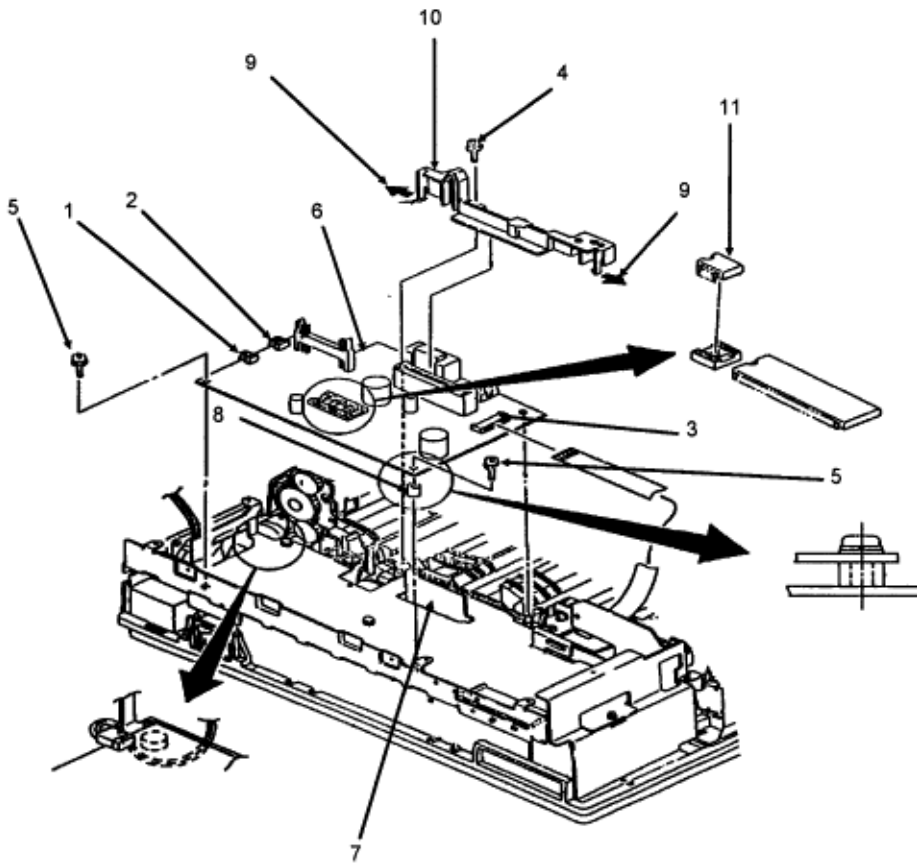

Copyright 1997, Okidata, Division of OKI America, Inc. All rights reserved. See the OKIDATA Business Partner Exchange (BPX) for any updates to this material. (<http://bpx.okidata.com>)

3.2.09 Main Motor

1. Perform these procedures: 3.2.01, 3.2.02, 3.2.05, 3.2.06, 3.2.07, and 3.2.08.
2. Remove the three mounting screws (1).
3. Remove shield plate A (2), which has shield plate C (3) attached.
4. Remove the screw (4).
5. Remove the shield plate C.
6. Remove the interconnect board (5). (Only the location of the board is shown)
7. Remove the two high voltage wires from the motor cover. (Not shown)
8. Working from the bottom of the printer, remove the motor cover (6) by releasing the two black claws (7).
9. Remove the motor cover.
10. Shift the main motor assembly (8) to the left and detach it from the posts of the lower unit .
11. Remove the main motor assembly.
12. Remove the two screws (9).
13. Remove the main motor from the motor bracket (10).

P/N 51008102 Plate: Shield A Assembly (OL810) RSPL B.2.09

P/N 51008301 Plate: Shield C RSPL B.2.09

P/N 53329301 Motor Bracket B.2.08

P/N 53528301 Motor Cover B.2.08

P/N 55046001 PCB: LLID RSPL B.2.09

P/N 56507701 Motor: Pulse (Main) RSPL B.2.08

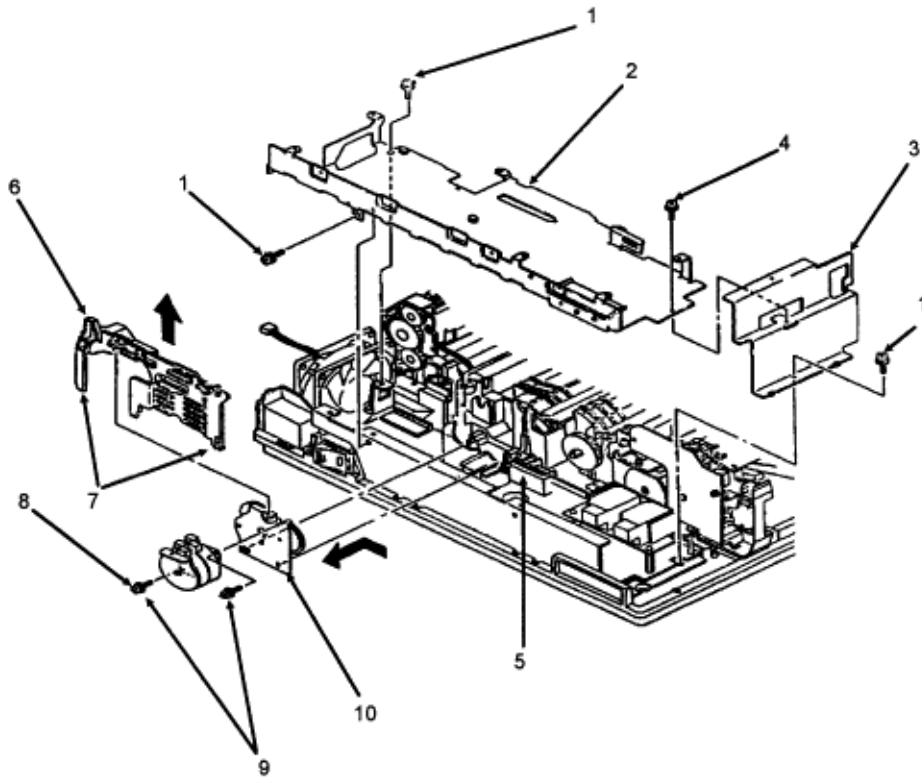

Copyright 1997, Okidata, Division of OKI America, Inc. All rights reserved. See the OKIDATA Business Partner Exchange (BPX) for any updates to this material. (<http://bpx.okidata.com>)

3.2.10 Idle Gear A, Idle Gear B, and Speed Reduction Gear

1. Perform these procedures: 3.2.01, 3.2.02, 3.2.05, 3.2.06, 3.2.07, 3.2.08 and 3.2.09.
2. Remove the idle gear B (1). This is the white gear with large teeth.
3. Remove the deceleration gear (2). This is the black double gear.
4. Remove idle gear A (3). This is the white gear with small teeth.

P/N 51218501 Gear: Idle "B" RSPL B.2.08

P/N 51218701 Gear: Speed Reduction RSPL B.2.08

P/N 51225701 Gear: Idle "A" RSPL B.2.08

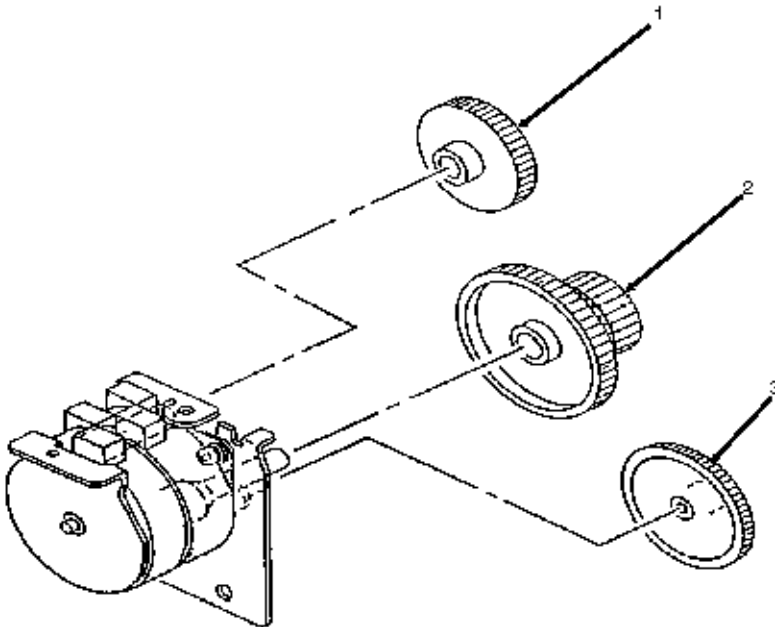

3.2.11 DC Fan Assembly

1. Perform these procedures: 3.2.01, 3.2.02, 3.2.05, 3.2.06, 3.2.07, and 3.2.08.
2. Disconnect the cable (1).
3. Remove the DC fan assembly (2).

P/N 56508501 Fan: DC (Assembly) RSPL B.2.07

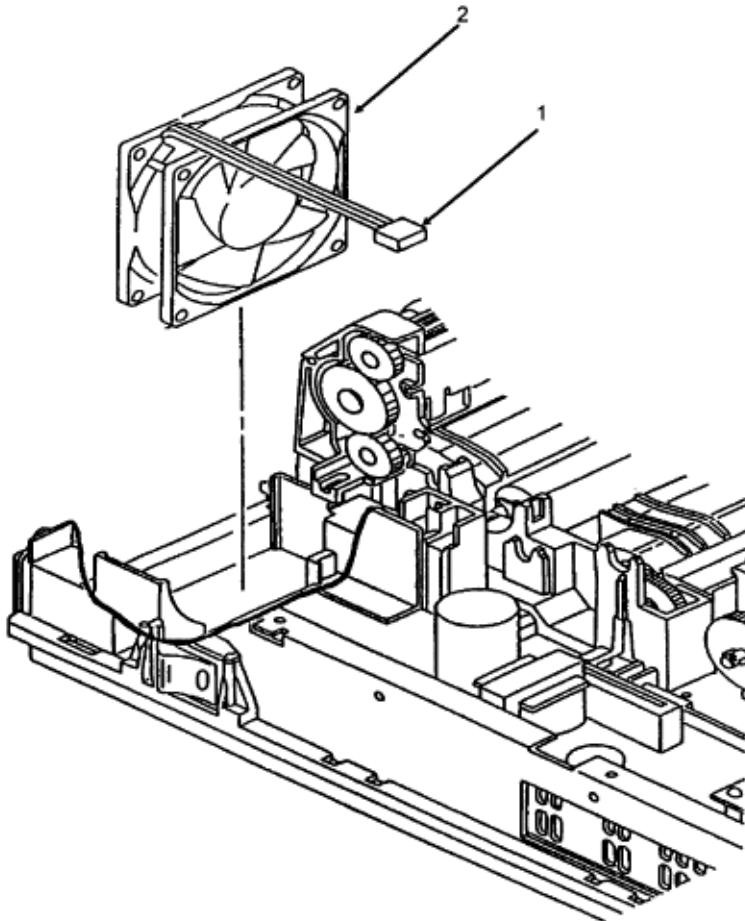

3.2.12 Power Supply Unit

1. Perform these procedures: 3.2.01, 3.2.02, 3.2.05, 3.2.06, 3.2.07, 3.2.08, 3.2.09, and 3.2.28.
2. Disconnect the two high-voltage cables (1).

NOTE:

When installing, the cables are keyed for correct placement. The larger connector is to the front of the printer.

3. Remove the screw (2) and detach the ground cable (3). [Only for 220/240 volt]
4. Remove the three screws (4).
5. Raise the upper unit .
6. Use needle nose pliers to remove the left torsion spring (5).
7. Lift the power supply unit (6) until it comes off the front guide (7) of the lower unit (8).
8. Slide the power supply unit towards the front to detach it from the rear claws (9) for removal.
9. Remove the AC cover (10) and AC contact plate (11). These items are located in the base frame. You must remove the power supply unit to access these items. However, you do not have to remove these items to remove the power supply unit.

P/N 50918101 Torsion Spring (Left) B.2.04

P/N 53057901 AC Contact Plate B.2.09

P/N 53502301 AC Cover B.2.09

P/N 56408708 Power Supply (220/240V) Option B.2.09 and 12

P/N 56408710 Power Supply (120V) RSPL B.2.09

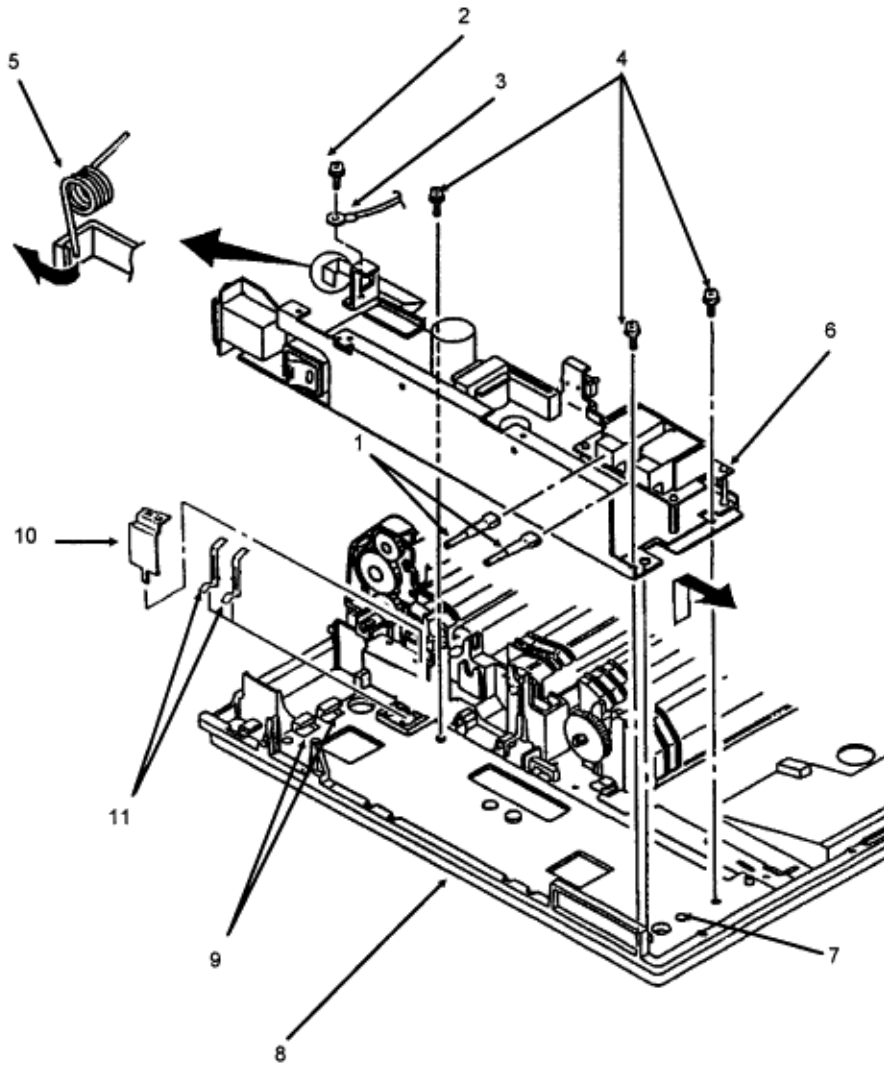

Copyright 1997, Okidata, Division of OKI America, Inc. All rights reserved. See the OKIDATA Business Partner Exchange (BPX) for any updates to this material. (<http://bpx.okidata.com>)

3.2.13 Cover Open Microswitch Assembly

1. Perform these procedures: 3.2.01, 3.2.02, 3.2.05, 3.2.06, 3.2.07, 3.2.08, and 3.2.09.
2. Remove the screw (1).
3. Detach the connector (2).
4. Remove the microswitch assembly (3).

N/A Microswitch Assembly (220-240V) Option RSPL B.2.09 and 12

P/N 55050721 Microswitch Assembly (120V) RSPL B.2.09

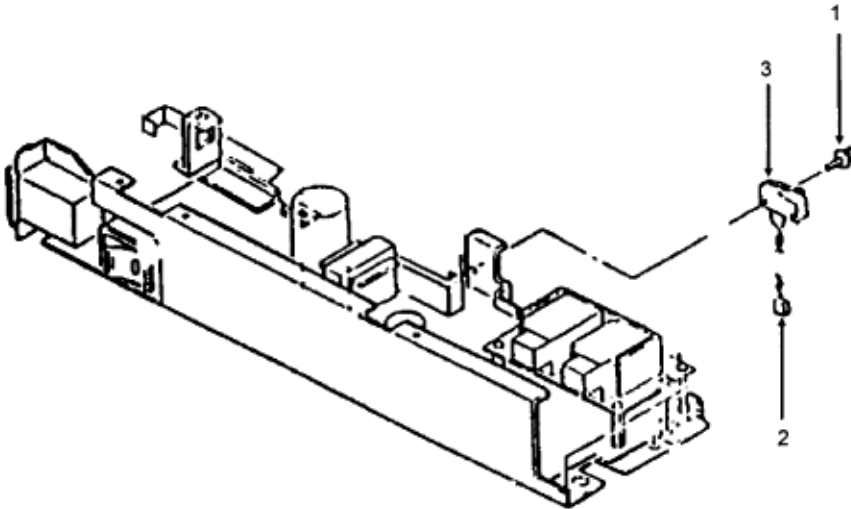

3.2.14 Paper Eject Roller Assembly

1. Perform these procedures: 3.2.01 and 3.2.02.
2. Place the face-up stacker assembly, located at the rear of the printer, down.
3. Press the lock lever and raise the upper unit.
4. Remove the mounting screw (1).
5. Remove the ground cable at the power supply (Not shown - 220/240 volt only).
6. Slightly lift the paper eject roller assembly (2) at its left end and slide the left end backward using the right end as a pivot.
7. Remove the paper eject roller assembly.
8. Separate the left (3) and right (4) springs and remove the bias rollers (5).

N/A Paper Eject Roller Assembly B.2.10

P/N 50918401 Bias Spring (Left) B.2.07

P/N 50918501 Bias Spring (Right) B.2.07

P/N 53334601 Bias Roller B.2.07

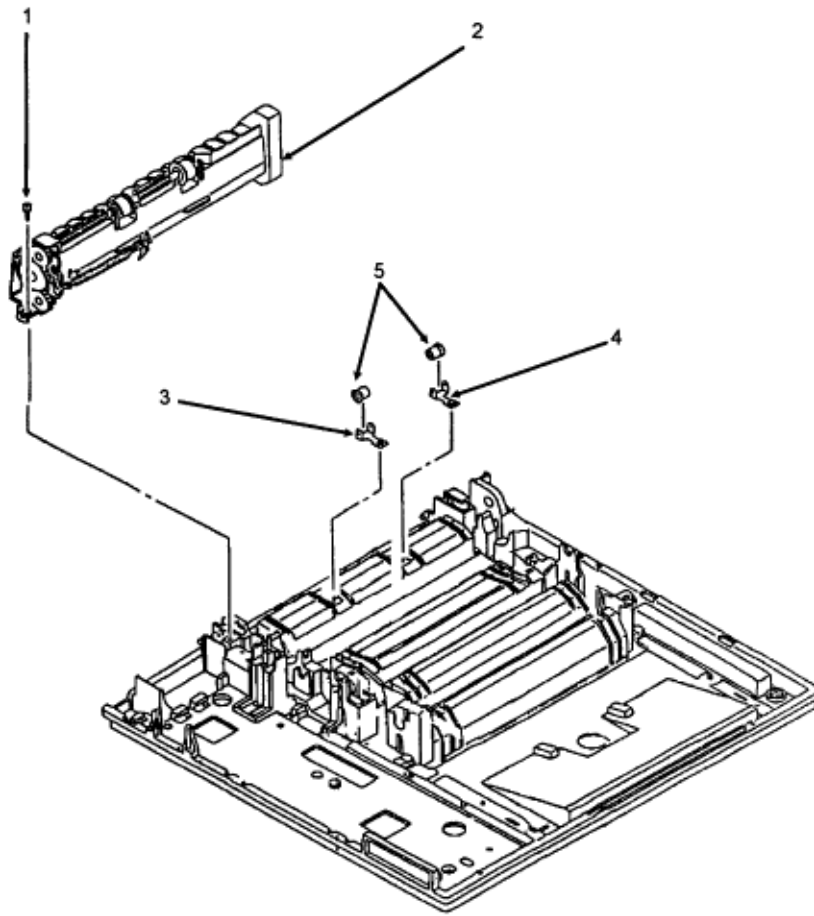

Copyright 1997, Okidata, Division of OKI America, Inc. All rights reserved. See the OKIDATA Business Partner Exchange (BPX) for any updates to this material. (<http://bpx.okidata.com>)

3.2.15 Paper Eject Sensor Lever and Rollers

1. Perform these procedures: 3.2.01, 3.2.02, and 3.2.14.
2. Turn the paper eject roller assembly over and remove the paper eject sensor lever (1).
3. Remove the E-ring (2) and remove the paper eject idle gear (3) from the sheet guide (4).
4. Remove the face-up paper eject roller shaft (5) with paper eject rollers (6).
5. Remove the paper eject roller shaft (7) with face-up paper eject rollers (8).
6. Detach the sheet separator (9).

NOTE:

The face-up paper eject roller shaft and the paper eject roller shaft are the same roller and have the same part number.

P/N 50705301 E-Ring B.2.10

P/N 51005201 Sheet Guide B.2.10

P/N 51223201 Idle Gear "C" (OL810) RSPL B.2.11

P/N 51111401 Paper Eject Roller Shaft B.2.10

P/N 51222801 Idle Gear (Paper Eject) B.2.10

P/N 53334401 Paper Eject Roller B.2.10

P/N 53334501 Paper Eject Roller (Face-up) B.2.10

P/N 53528101 Sensor Lever (Paper Eject) B.2.10

P/N 53528201 Sheet Separator B.2.10

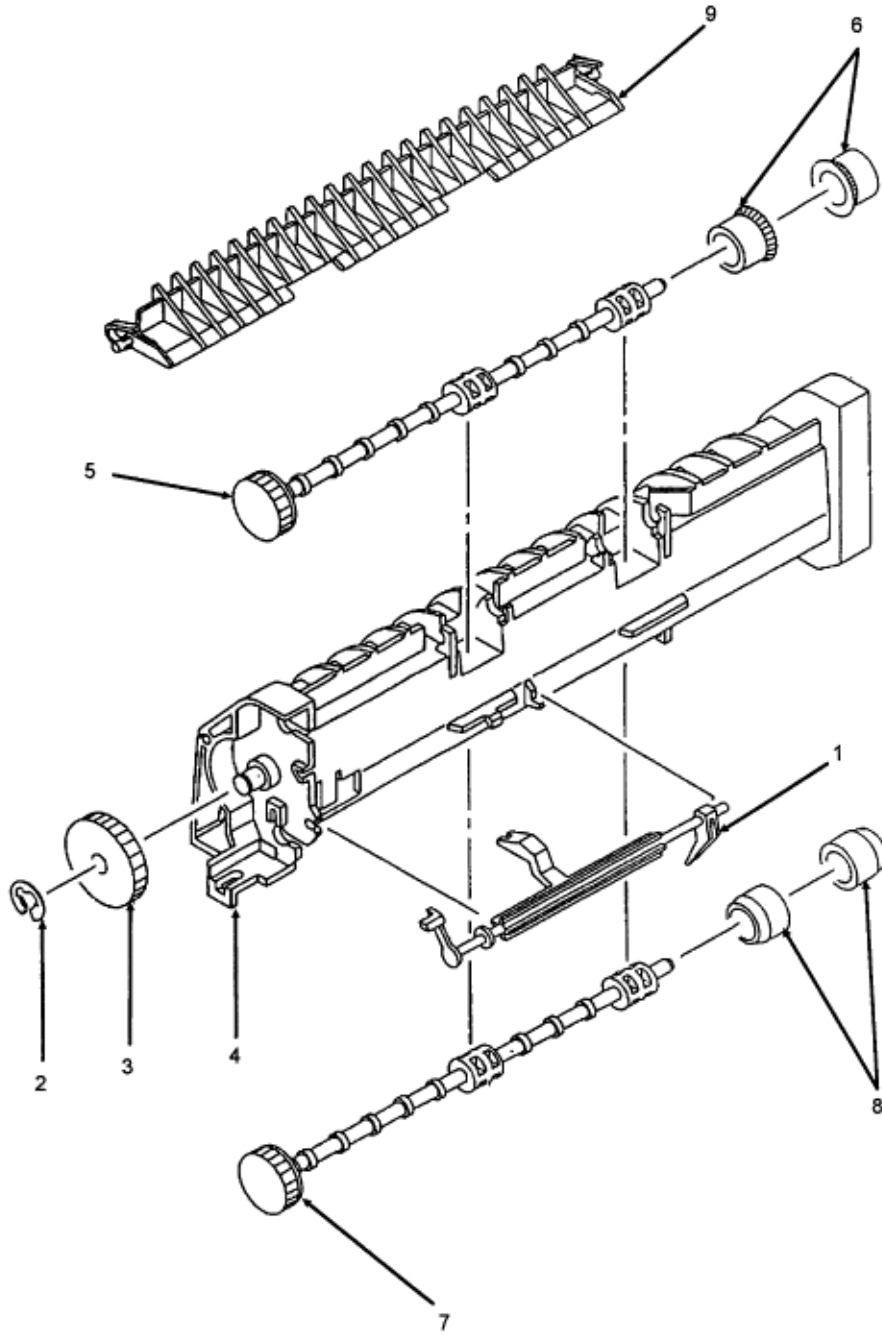

Copyright 1997, Okidata, Division of OKI America, Inc. All rights reserved. See the OKIDATA Business Partner Exchange (BPX) for any updates to this material. (<http://bpx.okidata.com>)

3.2.16 Upper Unit

1. Perform these procedures: 3.2.01, 3.2.02, 3.2.05, 3.2.06, 3.2.07, 3.2.08, and 3.2.11.
2. Use needle nose pliers to remove the left torsion spring (1).
3. Use needle nose pliers to remove the right torsion spring (2).
4. Loosen the two mounting screws (3).
5. Lift the upper unit (4).
6. Slide the upper unit to the right and work it free of the right slot to remove it.

CAUTION:

Be careful not to drop the fulcrum block (5) and the idle gear (6) when removing the upper unit.

P/N 50213706 Unit: Upper (120V) RSPL B.2.02

P/N 50213707 Unit: Upper (220/240V) Option B.2.02 and 12

P/N 50918101 Torsion Spring (Left) B.2.04

P/N 50918201 Torsion Spring (Right) B.2.04

P/N 51005001 Fulcrum Block B.2.04

P/N 51218501 Gear: Idle "B" RSPL B.2.04

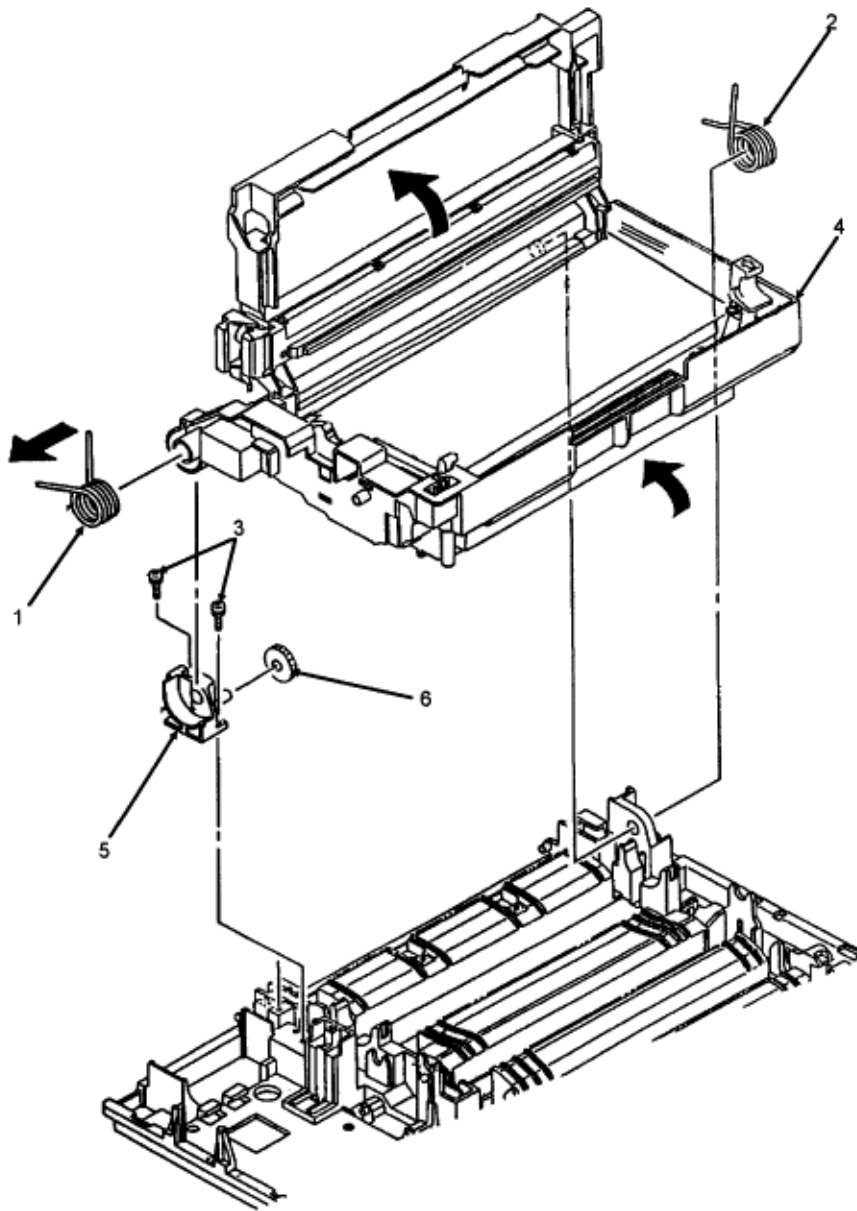

Copyright 1997, Okidata, Division of OKI America, Inc. All rights reserved. See the OKIDATA Business Partner Exchange (BPX) for any updates to this material. (<http://bpx.okidata.com>)

3.2.17 Cover Open Switch Actuator

1. Perform this procedure: 3.2.01.
2. Press the OPEN switch and raise the stacker cover.
3. Push the lock lever back and raise the upper unit.
4. Using a small screwdriver, push the actuator (1) from the bottom until it is released from the upper unit.
5. Remove the actuator.

P/N 50312501 Actuator B.2.04

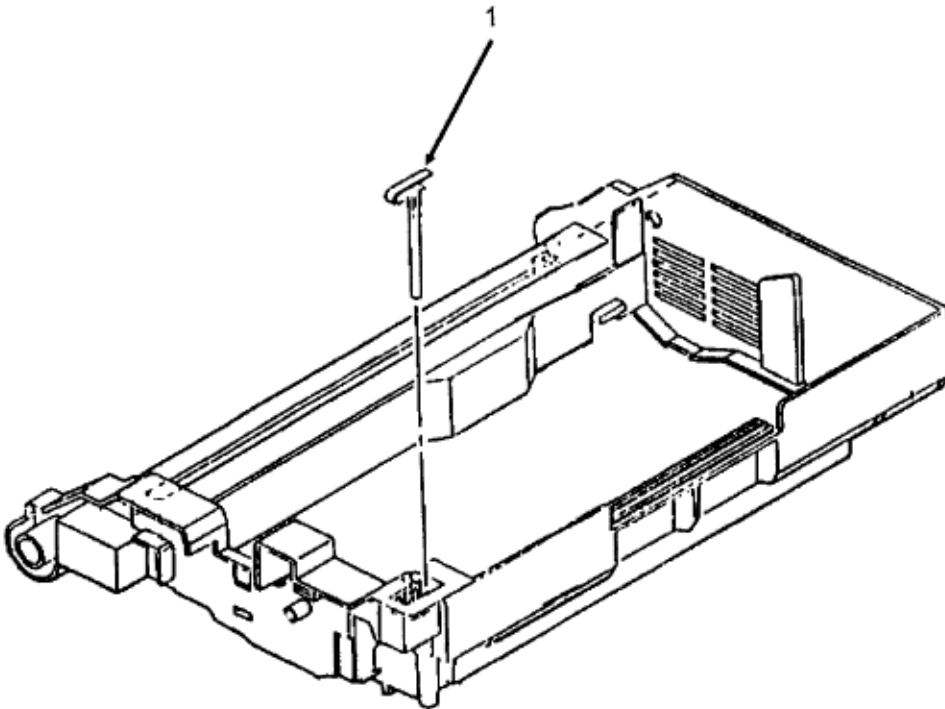

3.2.18 Paper Eject Sensor Levers B and C

1. Perform these procedures: 3.2.01, 3.2.02, and 3.2.14.
2. Use needle nose pliers to squeeze the claws (1) of the eject sensor "B" lever (2) to disengage it from the eject sensor "C" lever (3).
3. Remove both levers.

P/N 53527801 Paper Eject Sensor Lever B B.2.04

P/N 53527901 Paper Eject Sensor Lever C B.2.04

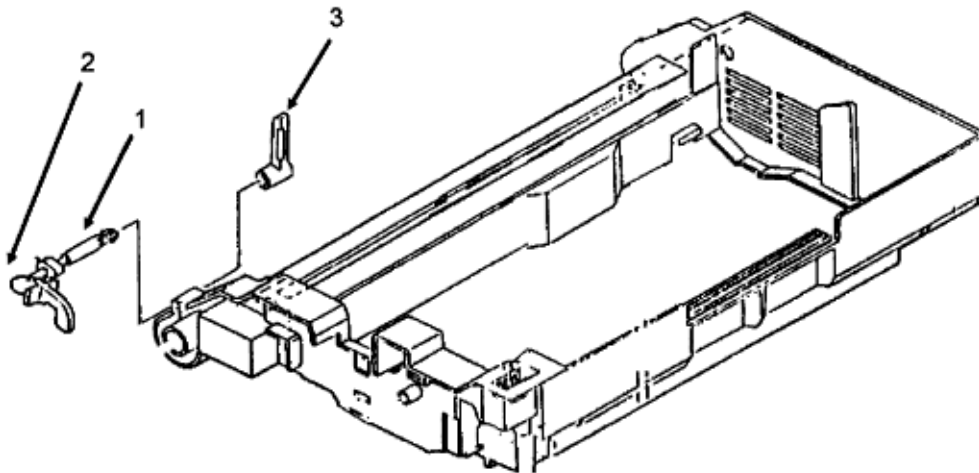

3.2.19 Fusing Unit

WARNING:

Allow the printer to cool before servicing the fusing unit.

1. Perform these procedures: 3.2.01, 3.2.02, 3.2.05, 3.2.06, 3.2.07, 3.2.08, 3.2.11, and 3.2.16.
2. Remove fuser cleaner pad (1).
3. Detach the cable (2) from the cable guide (3) of the upper unit.
4. Pass the connector (4) through the slot in the upper unit and work the cable from the upper unit guides.
5. Position the upper unit, its underside is facing you, with the fusing unit (5) at the top.
6. Squeeze the fusing unit against the upper unit until the two lock plates protrude from their slots. (Not shown)
7. Slide the fusing unit to the right until the lock plates disengage from the grooves of the upper unit. (Not shown)
8. Remove the fusing unit, being careful not to lose the springs (6).

Installation

9. The four separator claws must move freely within their grooves or paper jams will result.
10. Carefully position the fusing springs. At the grounding point, the latch plate will be positioned through the spring.
11. Be careful not to pinch the thermistor cable as you install the fusing unit. Be sure that the cable is placed in the notch.
12. Make sure that the fuser temperature cable is behind the heat shield and out of the path of the fuser cleaner pad.
13. After installing the fusing unit, reset the fusing unit counter. (Refer to Section 3.3 of this Service Handbook)

P/N 50914601 Spring: Fusing Unit RSPL B.2.05

P/N 53500901 Pad: Fuser Consumable B.2.04 and 16 In Toner Cartridge Kit

P/N 55044901 Unit: Fusing (120V) RSPL B.2.05

P/N 55044902 Unit: Fusing (220/240V) Option RSPL B.2.05 and 12

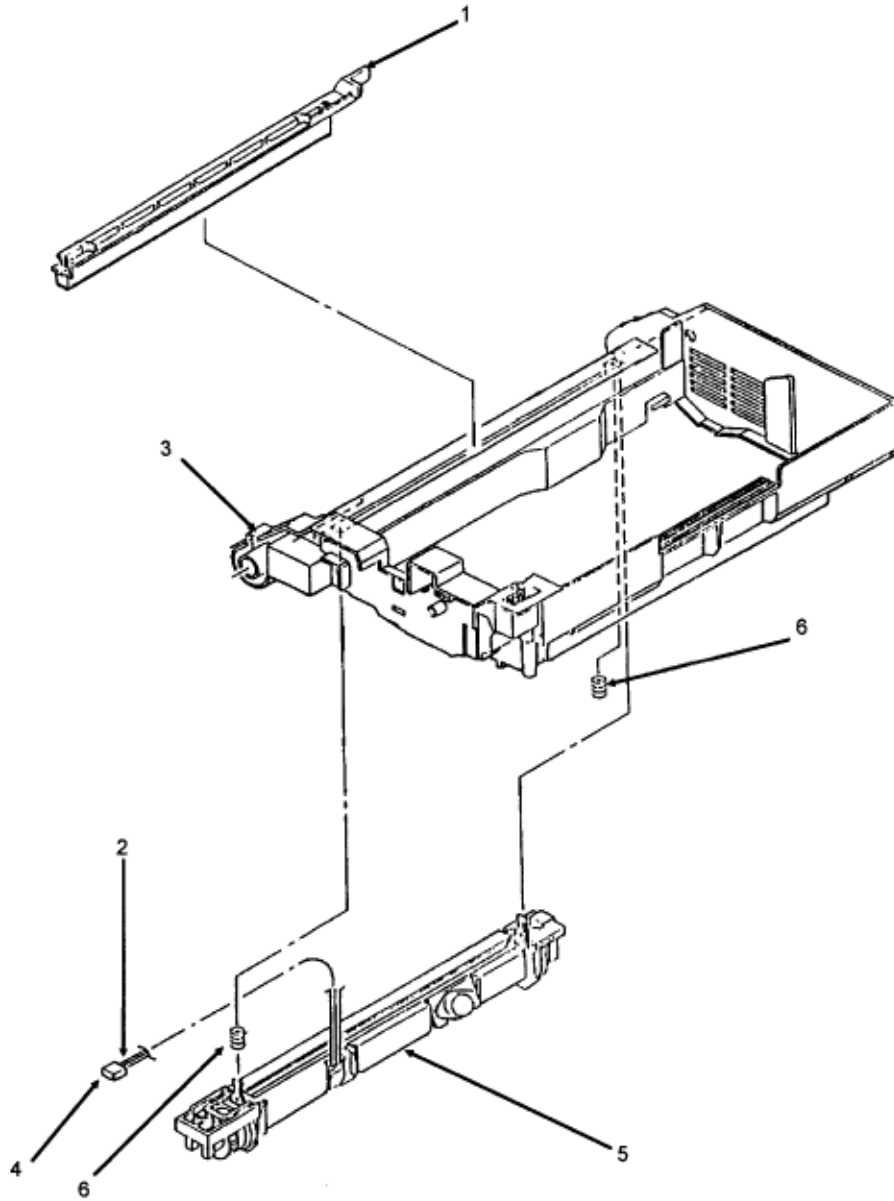

Copyright 1997, Okidata, Division of OKI America, Inc. All rights reserved. See the OKIDATA Business Partner Exchange (BPX) for any updates to this material. (<http://bpx.okidata.com>)

3.2.20 Metal Pressure Roller Assembly

1. Perform these procedures: 3.2.01, 3.2.02, 3.2.05, 3.2.06, 3.2.07, 3.2.08, 3.2.11, and 3.2.16.
2. Turn the upper unit over.
3. Firmly push down on both ends of the metal pressure roller (1) and slide the roller until the brackets (2) clear the guides. Be careful not to lose the springs (3).
4. Remove the brackets.
5. Remove the knock pin (4).
6. Remove the pressure roller gear (5).
7. Remove the registration ground plate (6).

P/N 50606208 Knock Pin B.2.05

P/N 50914501 Pressure Spring B.2.05

P/N 51222701 Pressure Roller Gear B.2.05

P/N 51605802 Bearing B.2.05

P/N 53334302 Pressure Roller B.2.05

P/N 56729701 Ground Plate (Registration) B.2.05

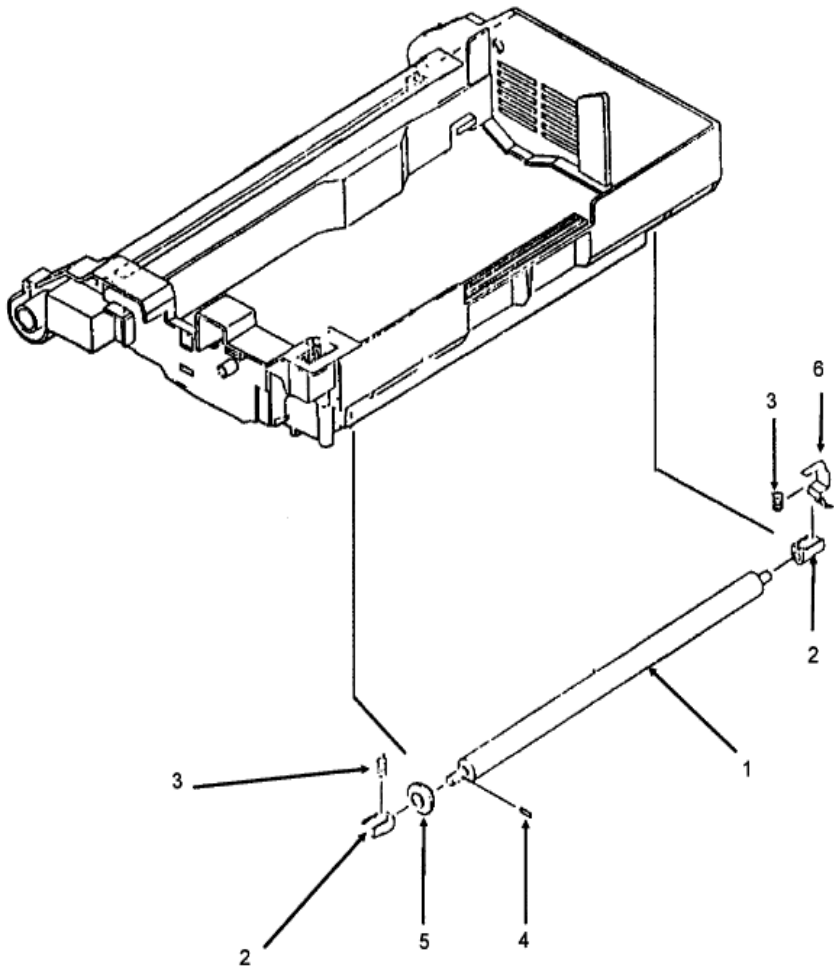

Copyright 1997, Okidata, Division of OKI America, Inc. All rights reserved. See the OKIDATA Business Partner Exchange (BPX) for any updates to this material. (<http://bpx.okidata.com>)

3.2.21 Registration Sensor Lever and Toner Sensor Lever

1. Perform this procedure: 3.2.01.
2. Press the lock lever and raise the upper unit.
3. Use needle nose pliers to squeeze the claws of the registration sensor flag (1) together and remove it from the registration sensor lever (2).
4. Use a small straight-slot screwdriver and detach the nylon rivet (3) from the toner sensor lever (4).

P/N 50606001 Rivet B.2.04

P/N 53329601 Sensor Flag (Registration) B.2.04

P/N 53503001 Sensor Lever (Registration) B.2.04

P/N 53527701 Sensor Lever (Toner) B.2.04

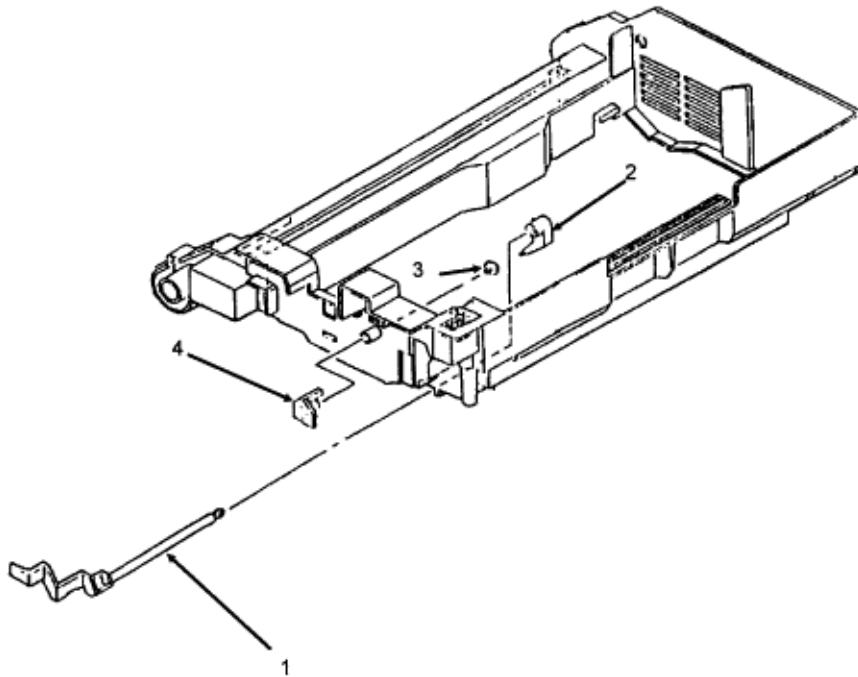

3.2.22 Lock Lever Assembly

1. Perform this procedure: 3.2.01.
2. Press the lock lever and raise the upper unit.
3. Detach the pressure springs (1) from the left (2) and right (3) lock levers.
4. Detach the claw of the left lock lever from the lock lever shaft (4).
5. Slide the left lock lever from the shaft until you can access the knock pin (5).
6. Use needle nose pliers to remove the knock pin.
7. Slide the lock lever shaft until you can remove the left lock lever.
8. Use needle nose pliers to remove the knock pin.
9. Remove the lock lever shaft and the right lock lever.

P/N 50606216 Knock Pin B.2.05

P/N 50917205 Spring: Image Drum Tray RSPL B.2.05

P/N 51110201 Lock Lever Shaft B.2.05

P/N 53502601 Lock Lever (Left) B.2.05

P/N 53502701 Lock Lever (Right) B.2.05

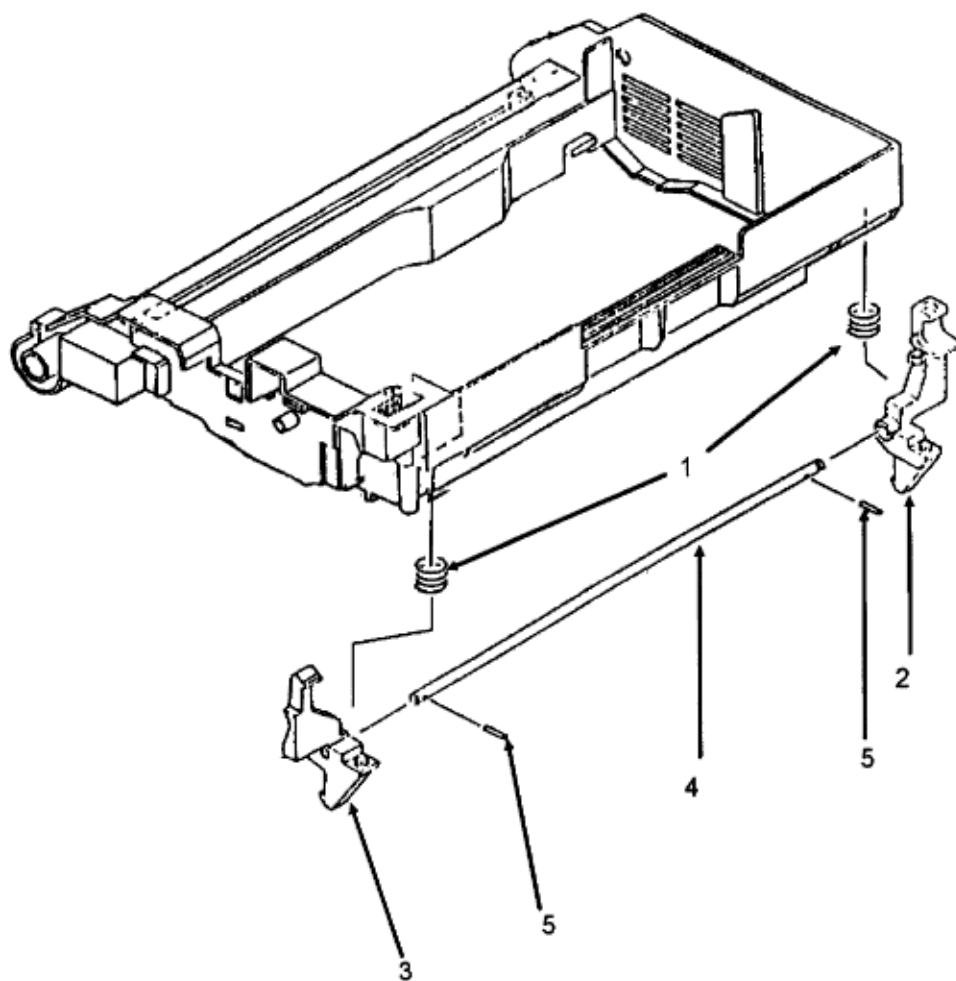

Copyright 1997, Okidata, Division of OKI America, Inc. All rights reserved. See the OKIDATA Business Partner Exchange (BPX) for any updates to this material. (<http://bpx.okidata.com>)

3.2.23 LED Head Holder

1. Perform these procedures: 3.2.01, 3.2.02, 3.2.05, 3.2.06, 3.2.07, 3.2.08, 3.2.11, and 3.2.16.
2. Press the release switches and open the LED head holder.
3. Using a straight-slot screwdriver, work the left support plate (1) free, being careful not to lose the drum ground plate (2).
4. Slide the LED head holder (3) until the shaft of the holder disengages from the point of the bracket of the upper frame (4).
5. Work the extension free of the opening and remove the LED head housing.

P/N 53058201 Ground Plate (Drum) B.2.04

P/N 53058901 Support Plate (Left) B.2.04

P/N 53329701 Upper Frame B.2.04

P/N 55619601 LED Head Housing B.2.06

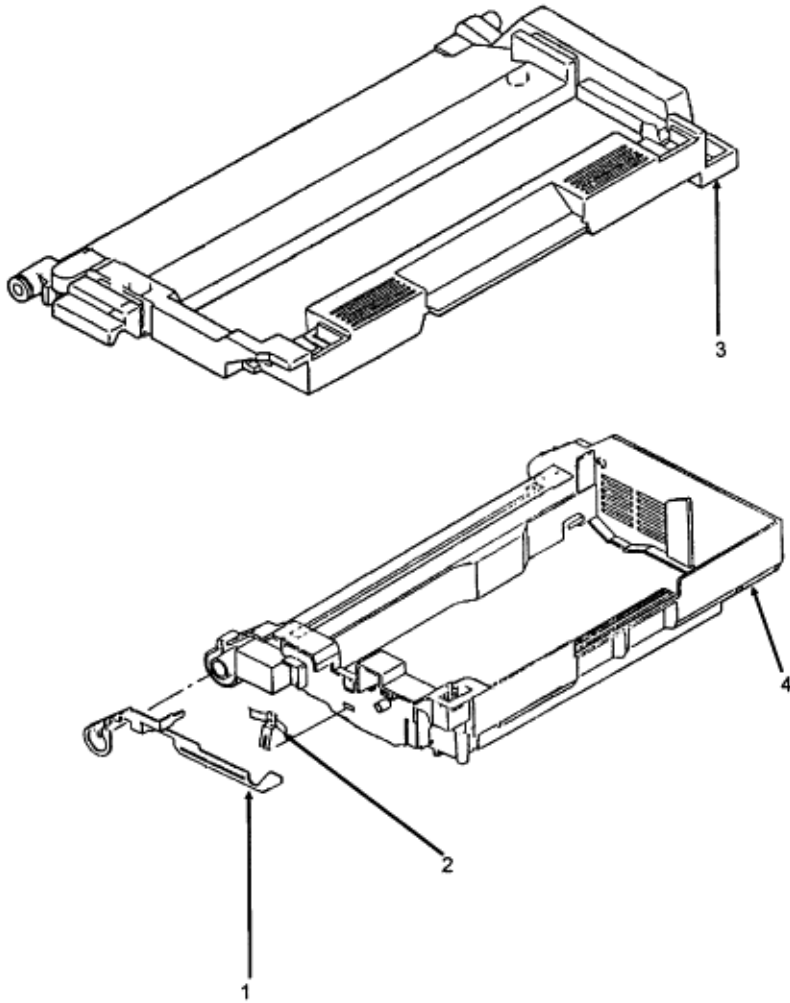

Copyright 1997, Okidata, Division of OKI America, Inc. All rights reserved. See the OKIDATA Business Partner Exchange (BPX) for any updates to this material. (<http://bpx.okidata.com>)

3.2.24 LED Holder Ground Plate

1. Perform this procedure: 3.2.01.
2. Press the release switches (1) and open the LED holder (2).

CAUTION:

DO NOT REMOVE THE RELEASE KNOBS AND SPRINGS (3).

3. Use a small straight slot screwdriver to pry the ground plate (4) free.
4. Remove the ground plate.

P/N 50918301 Pressure Spring B.2.06

P/N 51901301 Knob (Left) B.2.06

P/N 51901401 Knob (Right) B.2.06

P/N 53058401 Ground Plate (LED Head) B.2.06

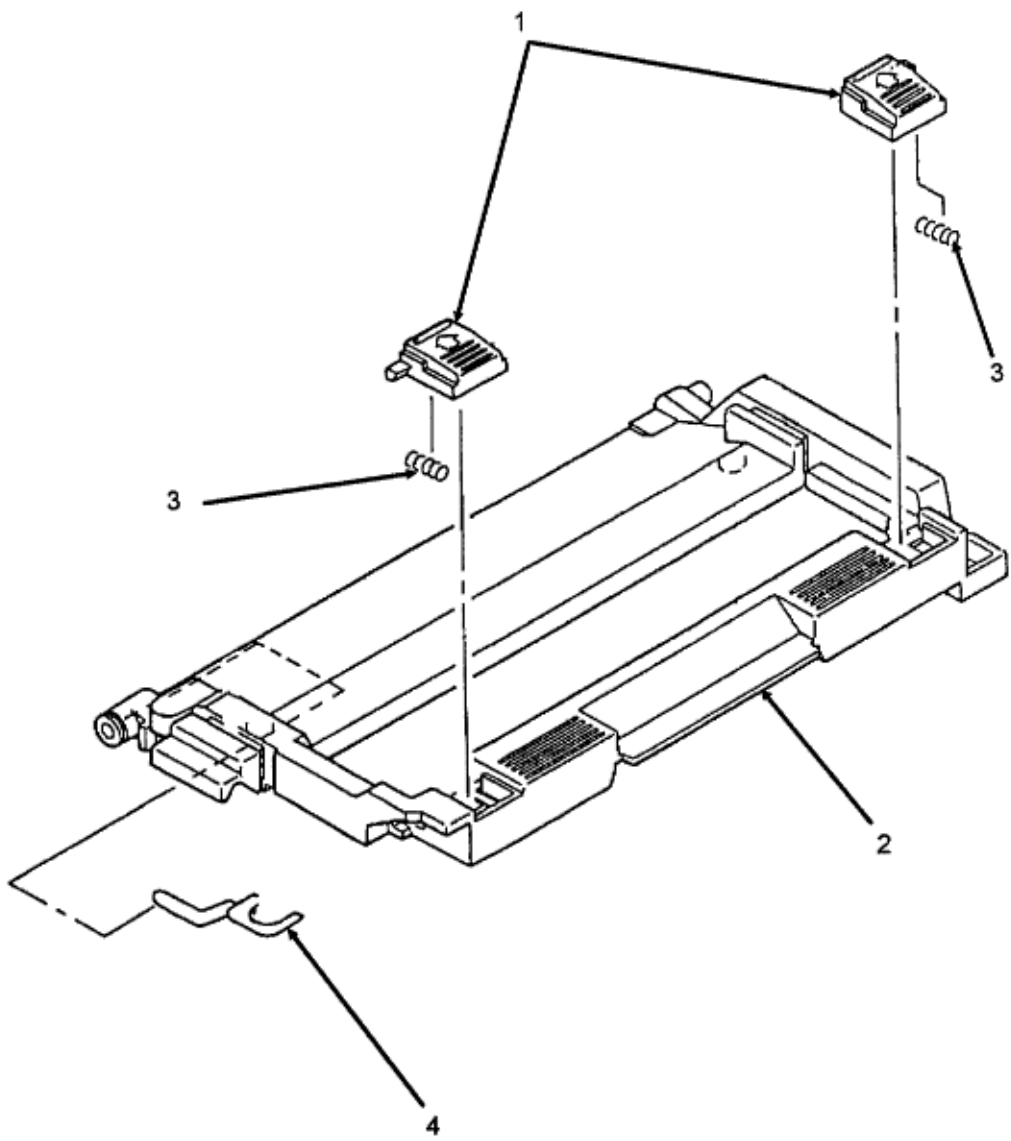

Copyright 1997, Okidata, Division of OKI America, Inc. All rights reserved. See the OKIDATA Business Partner Exchange (BPX) for any updates to this material. (<http://bpx.okidata.com>)

3.2.25 Pressure Roller Assembly

1. Perform these procedures: 3.2.01, 3.2.02, 3.2.05, 3.2.06, 3.2.07, 3.2.08, 3.2.11, and 3.2.16.
2. Remove the two mounting screws (1) to detach the sheet guide (2) and fusing guide (3).

NOTE:

You may have to use a straight slot screwdriver to detach the guides.

3. Remove the pressure roller (4).
4. Remove the pressure roller springs (5).
5. Remove the reinforcement plate (6).

P/N 50079201 Roller: Pressure (Assembly) RSPL B.2.07

P/N 50914801 Spring: Pressure Roller RSPL B.2.07

P/N 51003601 Sheet Guide B.2.07

P/N 51005101 Fusing Guide B.2.07

P/N 53335601 Reinforcement Plate B.2.07

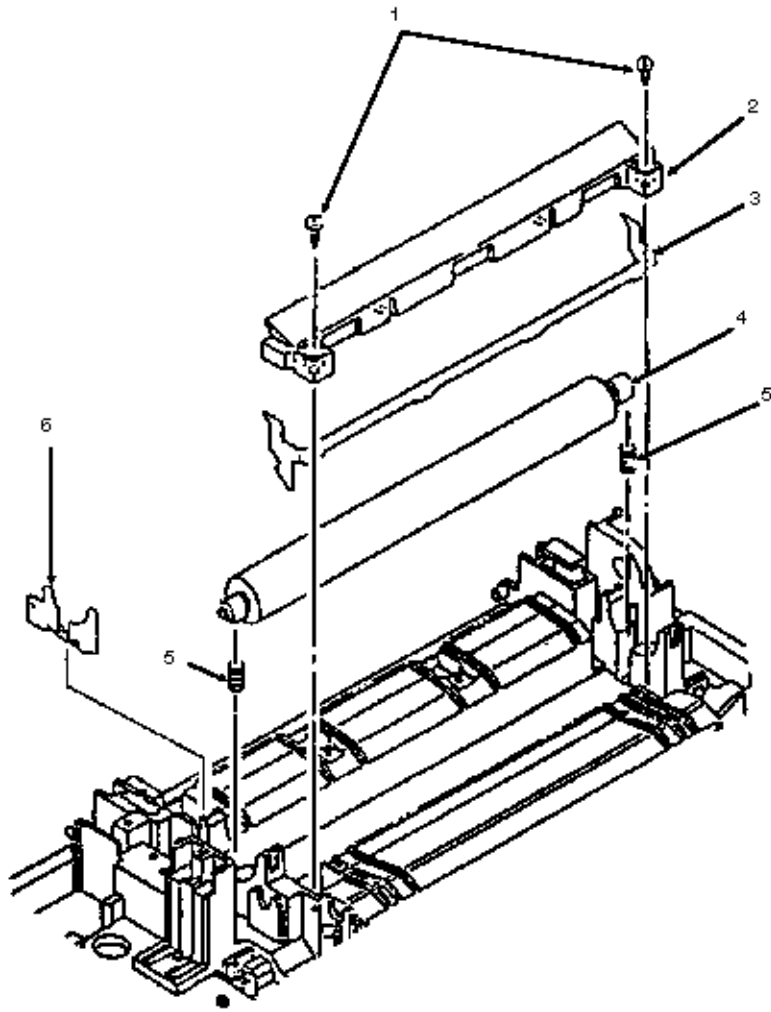

Copyright 1997, Okidata, Division of OKI America, Inc. All rights reserved. See the OKIDATA Business Partner Exchange (BPX) for any updates to this material. (<http://bpx.okidata.com>)

3.2.26 Transfer Charger Assembly

1. Perform this procedure: 3.2.01.
2. Push the lock lever towards the back of the printer and raise the upper unit.
3. Firmly push down and back on both sides (1) of the transfer charger assembly (2) until the lower cover claws are disengaged from the square holes on each end of the transfer charger assembly.

CAUTION:

When removing the transfer charger assembly, be careful not to break the tabs.

4. Lift and remove the transfer charger assembly.
5. Remove the end caps of the transfer charger assembly.
6. Using a needle nose pliers, detach the spring.
7. Detach the transfer wire from the clip and remove.
8. When installing the transfer wire, place it so the notch matches the dot in the diagram engraved at the bottom of the assembly.

CAUTION:

When installing the transfer charger assembly, make sure the assembly is locked under the claws. If the assembly is not locked, the image drum will be scratched.

NOTE:

When cleaning the transfer wire, use the cleaning tool (3) located under the LED holder. (Section 3.4, Cleaning)

P/N 50087401 Charger: Transfer (Assembly) RSPL B.2.07

P/N 53528001 Transfer Wire Cleaner B.2.04

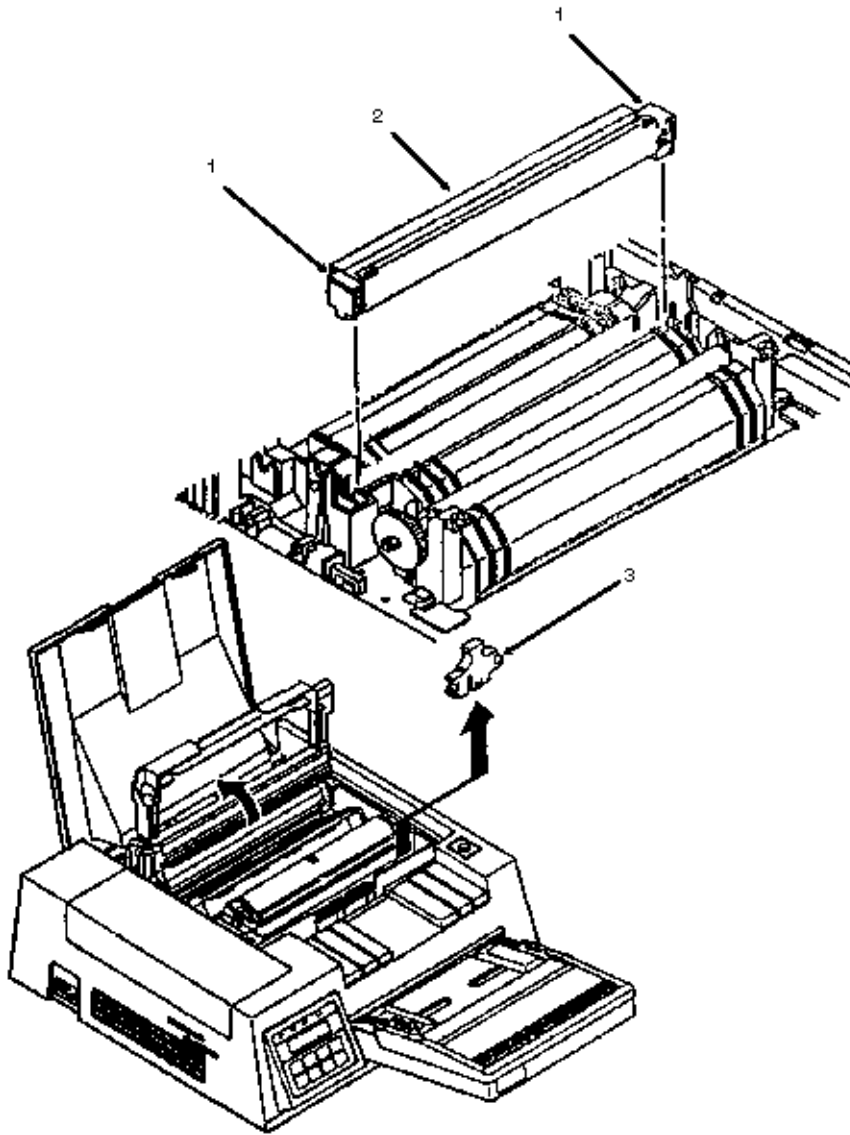

Copyright 1997, Okidata, Division of OKI America, Inc. All rights reserved. See the OKIDATA Business Partner Exchange (BPX) for any updates to this material. (<http://bpx.okidata.com>)

3.2.27 Registration Roller Assembly

1. Perform this procedure: 3.2.01.
2. Push the lock lever towards the rear of the unit and raise the upper unit.
3. Using a standard screwdriver, release the claws (1) from both sides of the registration roller assembly (2).

CAUTION:

The claws can be accessed from the bottom of the printer. Be careful when pushing on the claws.

Too much force could break them.

4. Remove the registration roller assembly.

P/N 50079101 Roller: Registration (Assembly) RSPL B.2.07

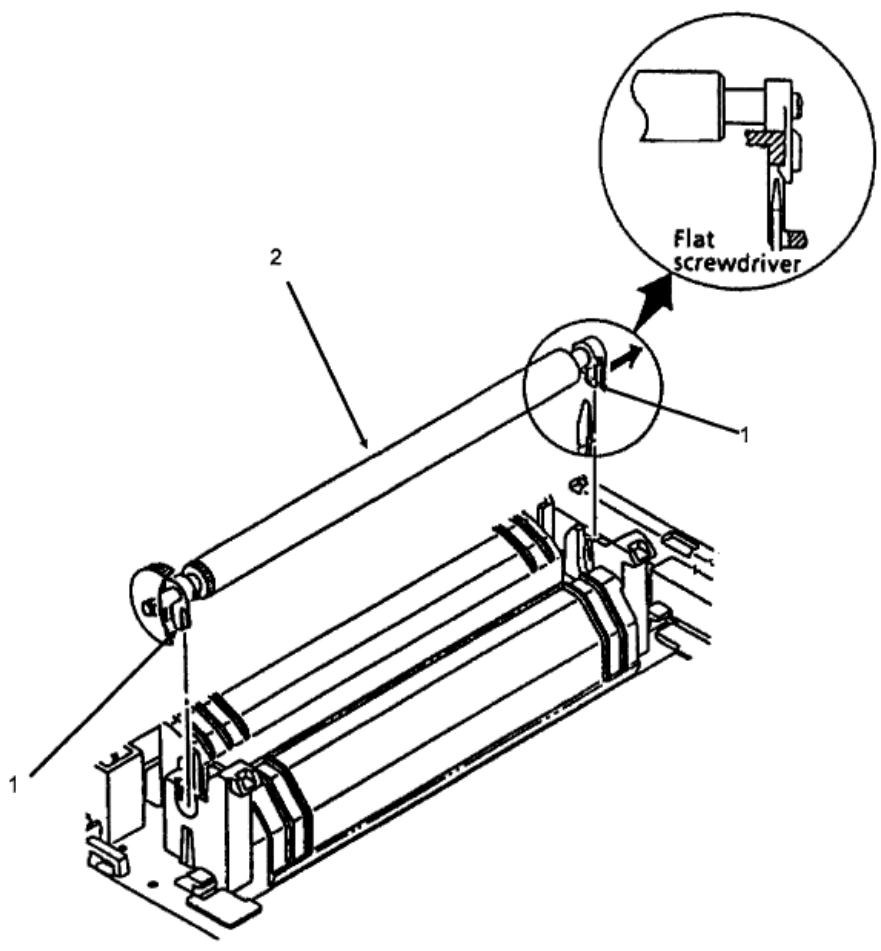

Copyright 1997, Okidata, Division of OKI America, Inc. All rights reserved. See the OKIDATA Business Partner Exchange (BPX) for any updates to this material. (<http://bpx.okidata.com>)

3.2.28 High Voltage Connector

1. Perform these procedures: 3.2.01, 3.2.02, 3.2.05, 3.2.06, 3.2.07, 3.2.08, and 3.2.09.
2. Working from the bottom of the unit, release the claw of the high voltage connector (1).
3. Set the unit down.
4. Use a straight-slot screwdriver and work the high voltage connector free.
5. Remove the high voltage connector.

P/N 56725901 High Voltage Connector B.2.08

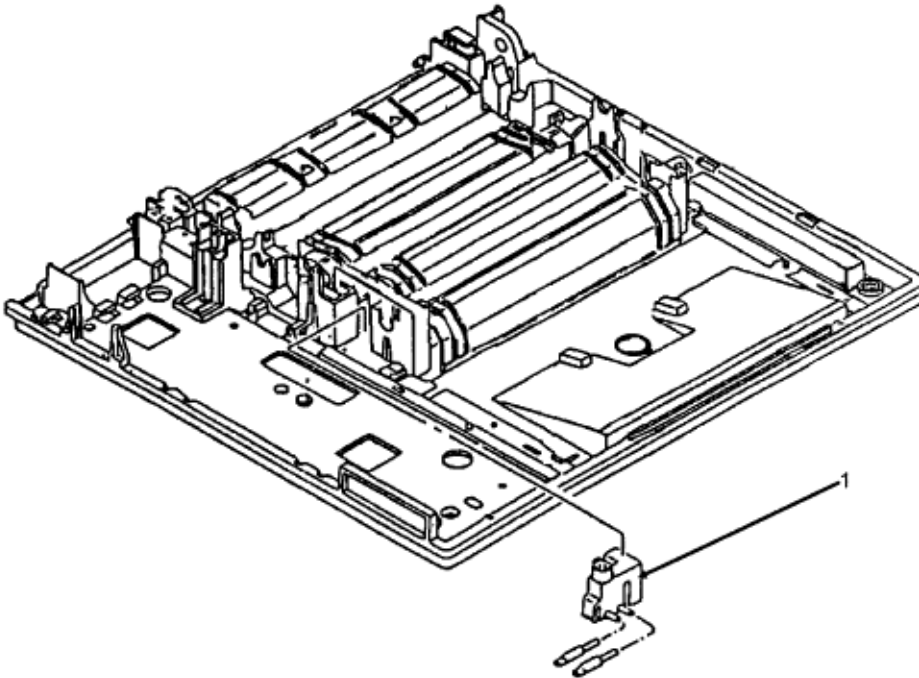

3.2.29 Idle Gear and Post

1. Perform these procedures: 3.2.01 and 3.2.26.
2. Use needle nose pliers to work the post (1) free of the guides.
3. Remove the post.
4. Remove base idle gear (2).

NOTE:

The cutout (3) on the post should be positioned to the left side of the printer and on the top when installing.

P/N 51218601 Gear: Idle (Base) RSPL B.2.08

P/N 53329501 Post RSPL B.2.08

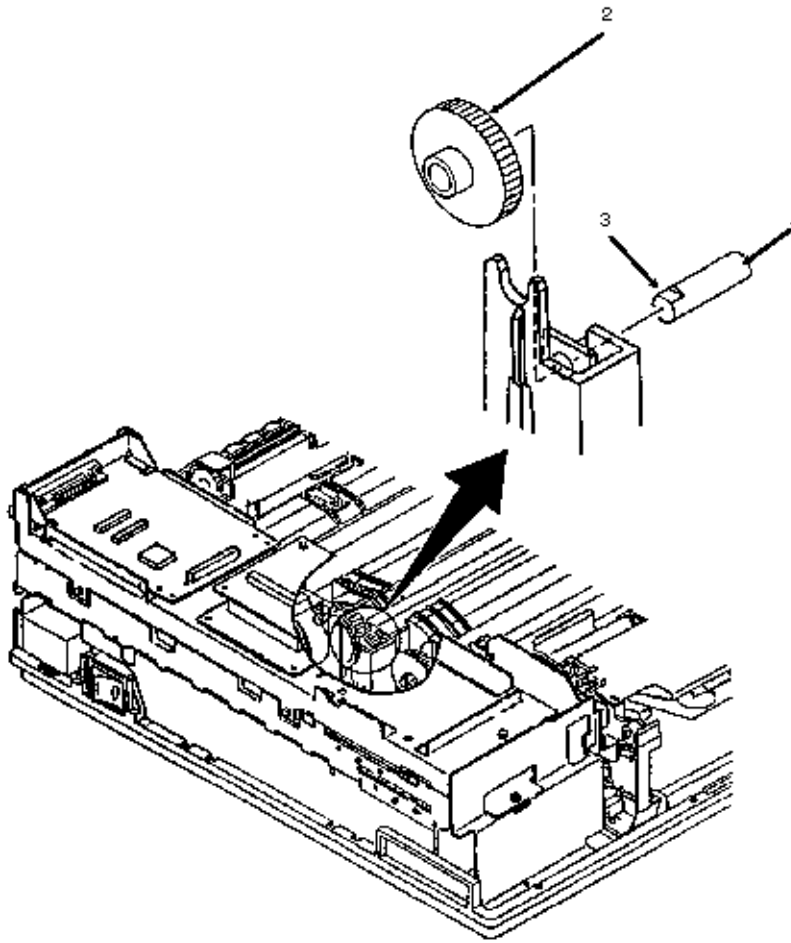

Copyright 1997, Okidata, Division of OKI America, Inc. All rights reserved. See the OKIDATA Business Partner Exchange (BPX) for any updates to this material. (<http://bpx.okidata.com>)

3.2.30 Paper Supply Unit

1. Perform these procedures: 3.2.01, 3.2.02, 3.2.05, 3.2.06, and 3.2.07.
2. Press the lock lever backward and raise the upper unit.
3. Disconnect the cable (1) from connector J5 (2) on the engine controller circuit board.
4. Remove the two mounting screws (3).
5. Lift the paper supply assembly (4) at its front until the frame of the unit comes off the guide pins, then move the unit towards you for removal.
6. Be careful not to lose the cassette spring (5).
7. Note the position of the static discharge cloth (6).

P/N 50214506 Unit: Paper Delivery RSPL B.2.07

P/N 50917001 Spring: Cassette RSPL B.2.07

P/N 51802501 Diselectrification Cloth B.2.08

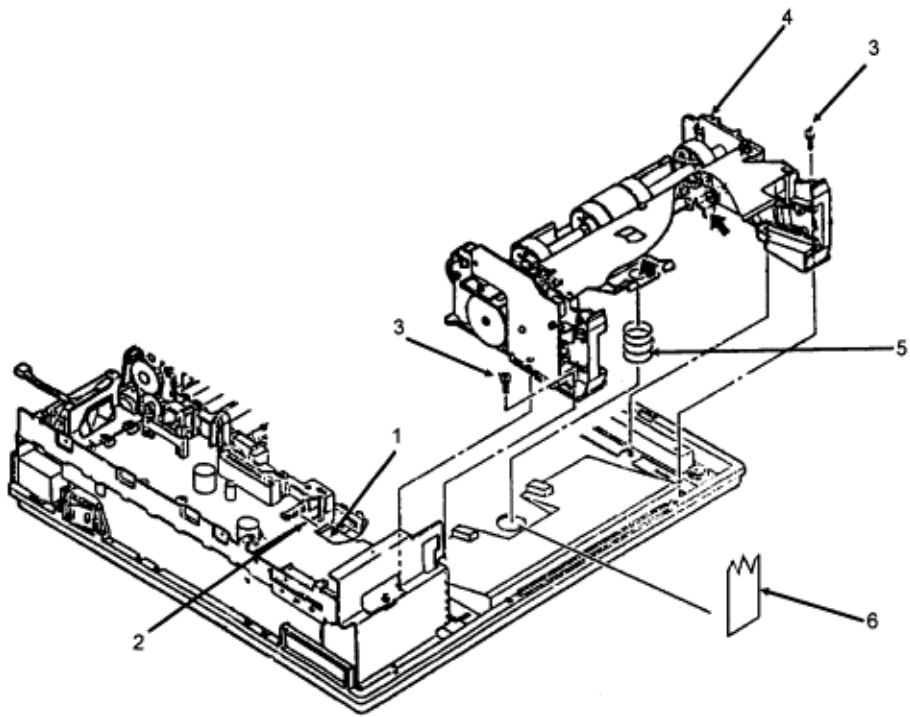

Copyright 1997, Okidata, Division of OKI America, Inc. All rights reserved. See the OKIDATA Business Partner Exchange (BPX) for any updates to this material. (<http://bpx.okidata.com>)

3.2.31 Registration Motor

1. Perform these procedures: 3.2.01, 3.2.02, 3.2.05, 3.2.06, 3.2.07, and 3.2.30.
2. Remove the screw (1).
3. Remove the two mounting screws (2).
4. Detach the registration motor (3) from the motor bracket (4).

P/N 53335002 Motor Bracket B.2.11

P/N 56507401 Motor: Pulse (Registration) RSPL B.2.11

P/N 51223101 Idle Gear "B" B.2.11

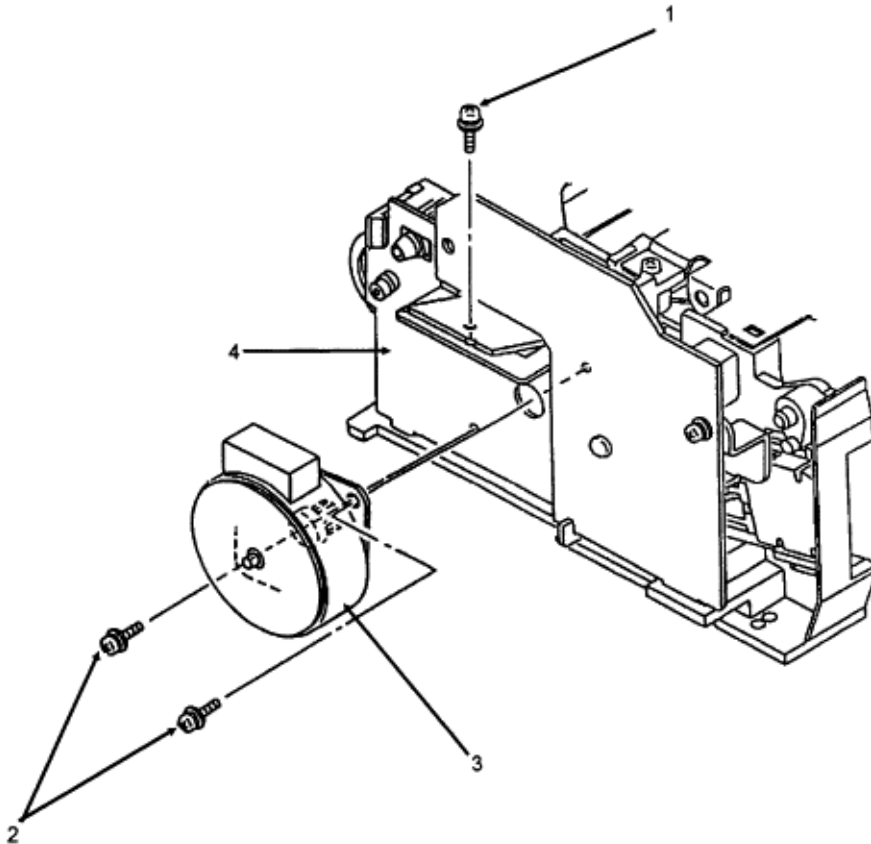

Copyright 1997, Okidata, Division of OKI America, Inc. All rights reserved. See the OKIDATA Business Partner Exchange (BPX) for any updates to this material. (<http://bpx.okidata.com>)

3.2.32 Engine Connector Board, LLCC

1. Perform these procedures: 3.2.01, 3.2.02, 3.2.05, 3.2.06, 3.2.07, and 3.2.30.
2. Remove the two mounting screws. (1)
3. On the paper supply unit, press the pointed end of the nylon latch (2) to push out the head (3)
4. Remove the latch.
5. Detach the engine connection board (4).

P/N 55044601 PCB: LLCC (Engine Connector) RSPL B.2.11

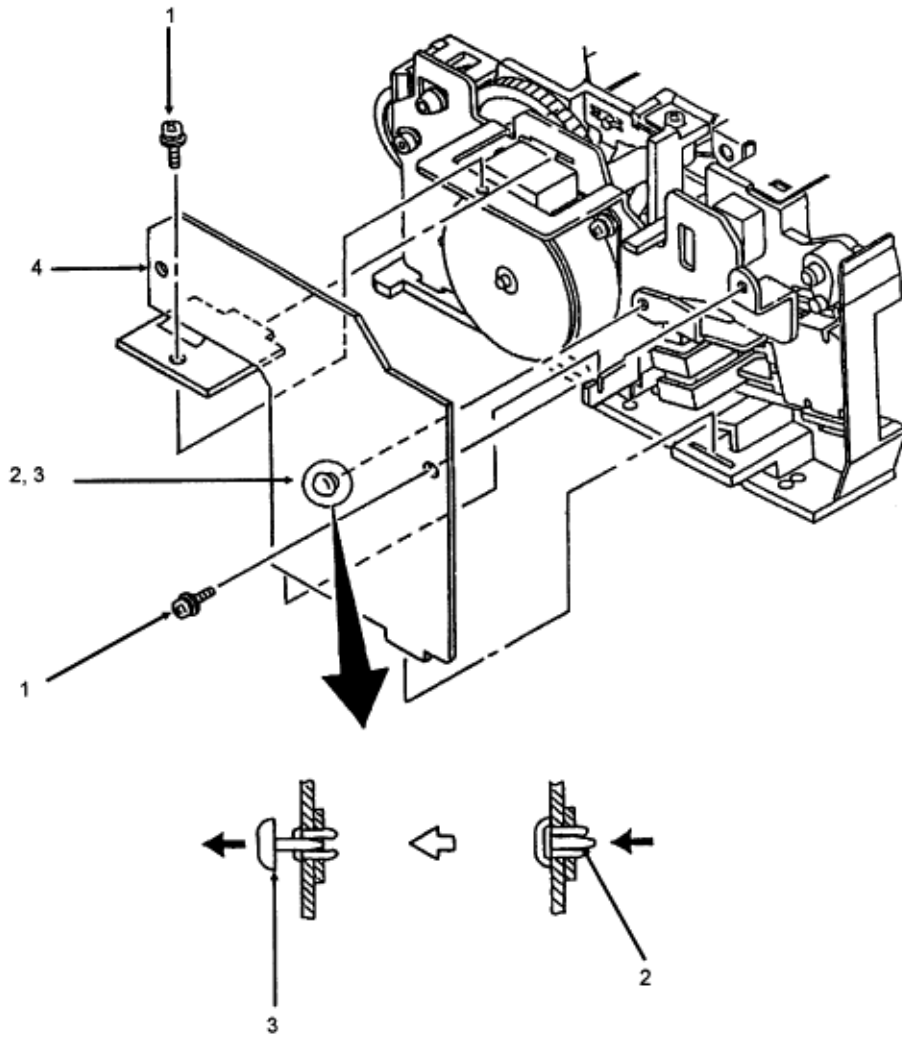

Copyright 1997, Okidata, Division of OKI America, Inc. All rights reserved. See the OKIDATA Business Partner Exchange (BPX) for any updates to this material. (<http://bpx.okidata.com>)

3.2.33 Hopping Roller A

1. Perform these procedures: 3.2.01, 3.2.02, 3.2.05, 3.2.06, 3.2.07, and 3.2.30.
2. Remove the two screws (1) and slide the upper plate assembly (2) until the claws (3) are unlocked.
3. Push the paper lever (4) down.
4. Remove the upper plate assembly.
5. Remove the screw (5).
6. Remove the ground plate (6).
7. Press the hopping roller shaft (7), then remove the pin (8) from the hopping roller gear (9).
8. Lift the right side of the hopping roller shaft and remove it.
9. Remove hopping roller B (10).
10. Remove the E-ring (11).
11. Remove hopping roller A (12).

NOTE:

When installing, always mount the hopping roller shaft above the ground plate, which is on the left side of the printer.

P/N 50081701 Roller: Hopping (Assembly) RSPL B.2.11

P/N 50705401 E-Ring B.2.11

P/N 51111501 Hopping Roller Shaft B.2.11

P/N 51222901 Hopping Gear B.2.11

P/N 51223001 Planet Gear B.2.11

P/N 53334901 Hopping Roller B B.2.11

P/N 53528501 Paper End Lever B.2.11

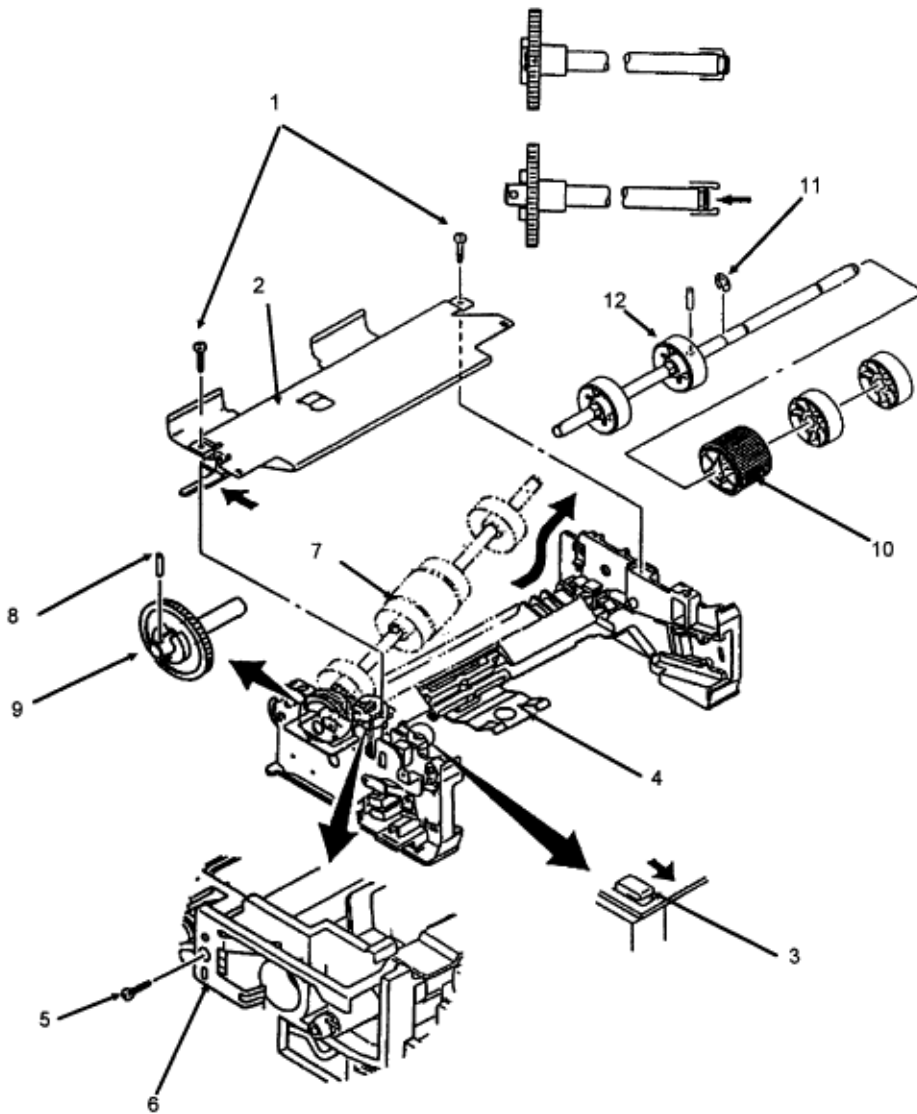

Copyright 1997, Okidata, Division of OKI America, Inc. All rights reserved. See the OKIDATA Business Partner Exchange (BPX) for any updates to this material. (<http://bpx.okidata.com>)

3.2.34 Separator

1. Perform these procedures: 3.2.01, 3.2.02, 3.2.05, 3.2.06, 3.2.07, and 3.2.30.
2. Hold the separator (1) down and remove the escape lever (2) from the pins on the paper supply unit. Be careful not to lose the separator spring (3).
3. Remove the separator.

P/N 50917101 Spring: Separator RSPL B.2.11

P/N 53500501 Separator RSPL B.2.11

P/N 53528601 Escape Lever B.2.11

P/N 50918601 Latch Spring B.2.11

P/N 51111601 Latch Shaft B.2.11

P/N 53335101 Upper Plate B.2.11

P/N 53335201 Side Frame Assembly (Left) B 2 11

P/N 53335301 Side Frame Assembly (Right) B.2.11

P/N 53335401 Separator Frame B.2.11

P/N 53528701 Setting Lever B.2.11

P/N 53528801 Latch Lever B.2.11

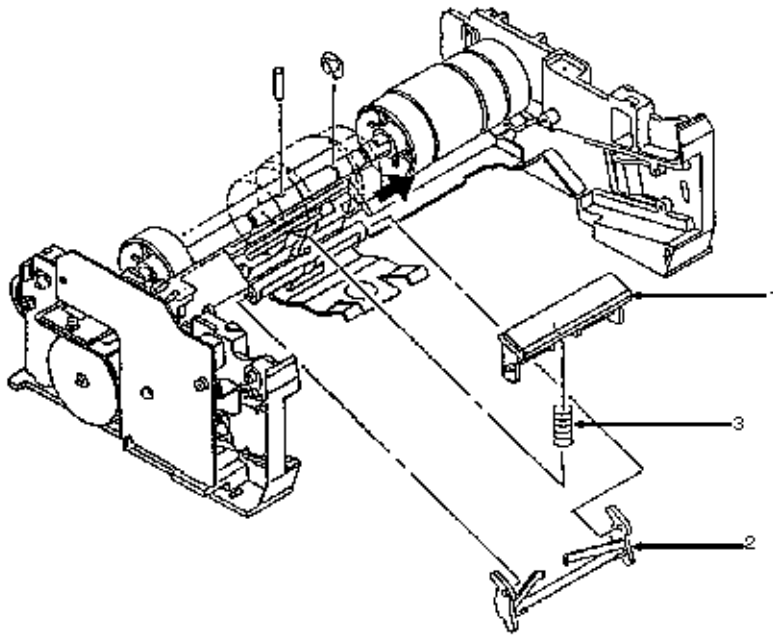

Copyright 1997, Okidata, Division of OKI America, Inc. All rights reserved. See the OKIDATA Business Partner Exchange (BPX) for any updates to this material. (<http://bpx.okidata.com>)

3.2.35 Base Frame

NOTE

The base frame is the plastic base for the printer. All previous disassembly procedures must be performed to reach the base frame.

The connector cap (1) may be accessed from the underneath the printer. No other disassembly procedures are required to access this part.

P/N 53057801 Base Frame B.2.07

N/A Cap B.2.08

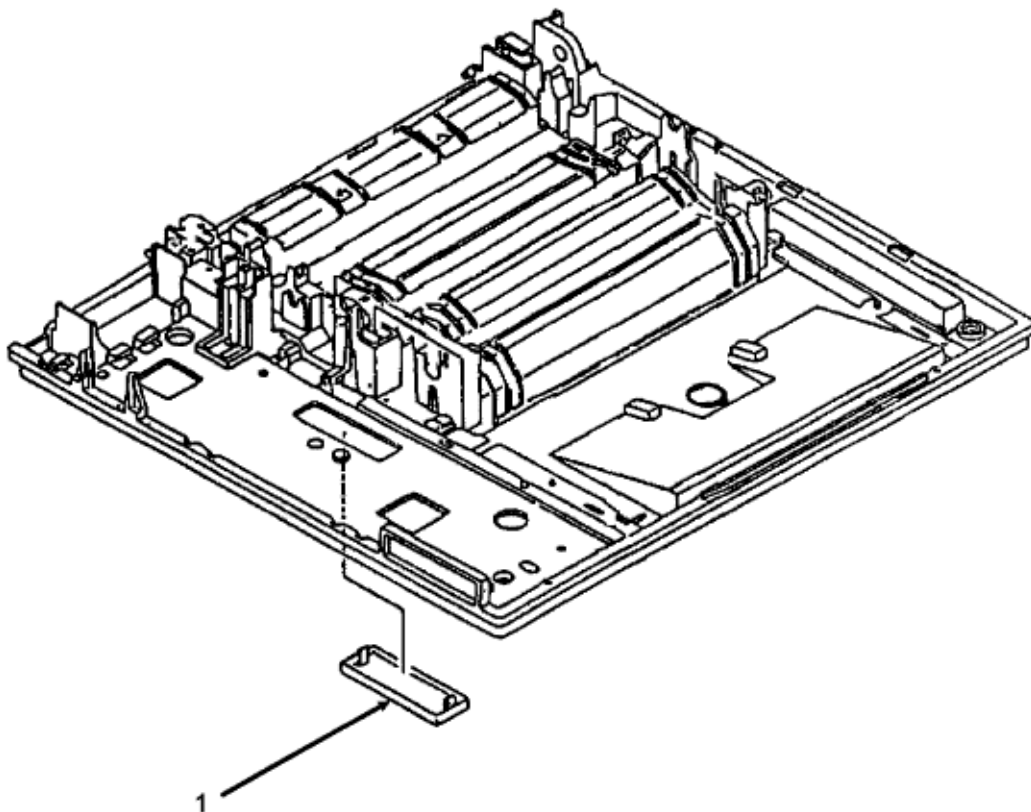

3.2.36 Ozone Filter**NOTE:**

A replacement ozone filter is provided with the image drum cartridge kit. The filter should be replaced when the image drum cartridge is replaced.

1. Perform this procedure: 3.2.01.
2. Using a screwdriver, insert the blade under the lower portion of the fan cover (1) and twist the screwdriver to remove the fan cover.
3. Remove the ozone filter (2) from the fan cover.

P/N 53527301 Fan Cover B.2.02

P/N 55503501 Filter: Ozone Consumable B.2.02 and 16 In Image Drum Cartridge Kit

P/N 56106601 Image Drum Kit Consumable B.2.16 Includes an Image Drum and Ozone Filter

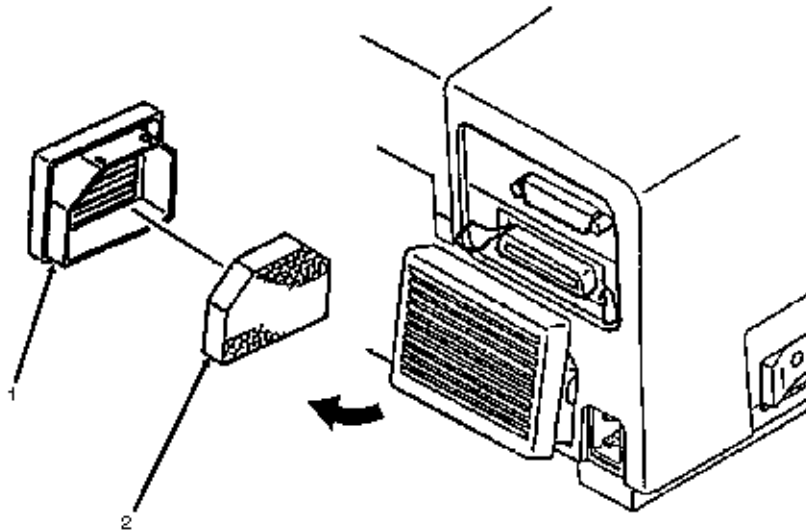

3.2.37 Second Paper Feed Unit (Option)

1. Perform this procedure: 3.2.01.
2. Lift the printer from the second paper feed unit (1).

Installation

When installing the optional second paper feed unit, you must remove the connector cap. The cap is accessed from the bottom of the printer.

3. Use a small straight-slot screwdriver to release the tabs of the cap (2).
4. Remove the cap.

P/N 51901701 Cap B.2.08

P/N 70018601 Second Paper Feed Unit Option B.2.12 and 14

P/N N/A Blind Cover B.2.14

P/N N/A Blind Cover (Rear Panel) B.2.14

P/N N/A Shield Base B.2.14

P/N N/A Thumb Screw B.2.14

P/N N/A Top Plate Assembly B.2.14

P/N 53059401 Lower Base B.2.14

P/N 53059501 Blind Cover B.2.14

P/N 53505301 Rubber Foot B.2.14

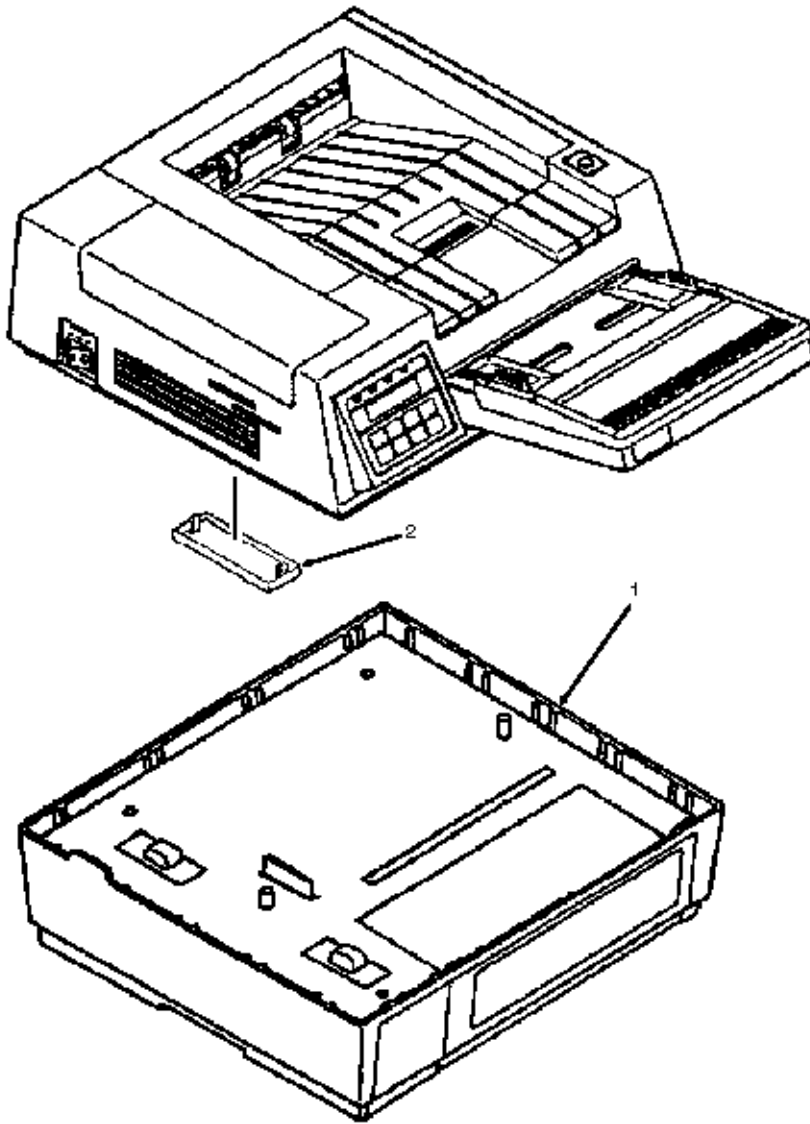

Copyright 1997, Okidata, Division of OKI America, Inc. All rights reserved. See the OKIDATA Business Partner Exchange (BPX) for any updates to this material. (<http://bpx.okidata.com>)

3.2.38 Second Paper Feed Unit Boards and Connectors

1. Perform these procedures: 3.2.01 and 3.2.37.
2. Squeeze the clamps on the ends of the connector (1) and lift to remove it.
3. Remove the eight screws (2).
4. Remove the shield (3).
5. Remove the connection board, LLIG (4).
6. Remove the four screws (5).
7. Remove the LLIF board (6).
8. Remove the screw (7).
9. Remove the shield (8) with connector AKJ-40AG (9).
10. Work the connector free of the bracket and remove the connector.

P/N 55067001 PCB: LLIF B.2.14

P/N 55067101 Connection PCB (LLIG) B.2.14

P/N 56725201 Connector AKJ-40AG B.2.14

P/N 56726001 Connector PM8DOX B.2.14

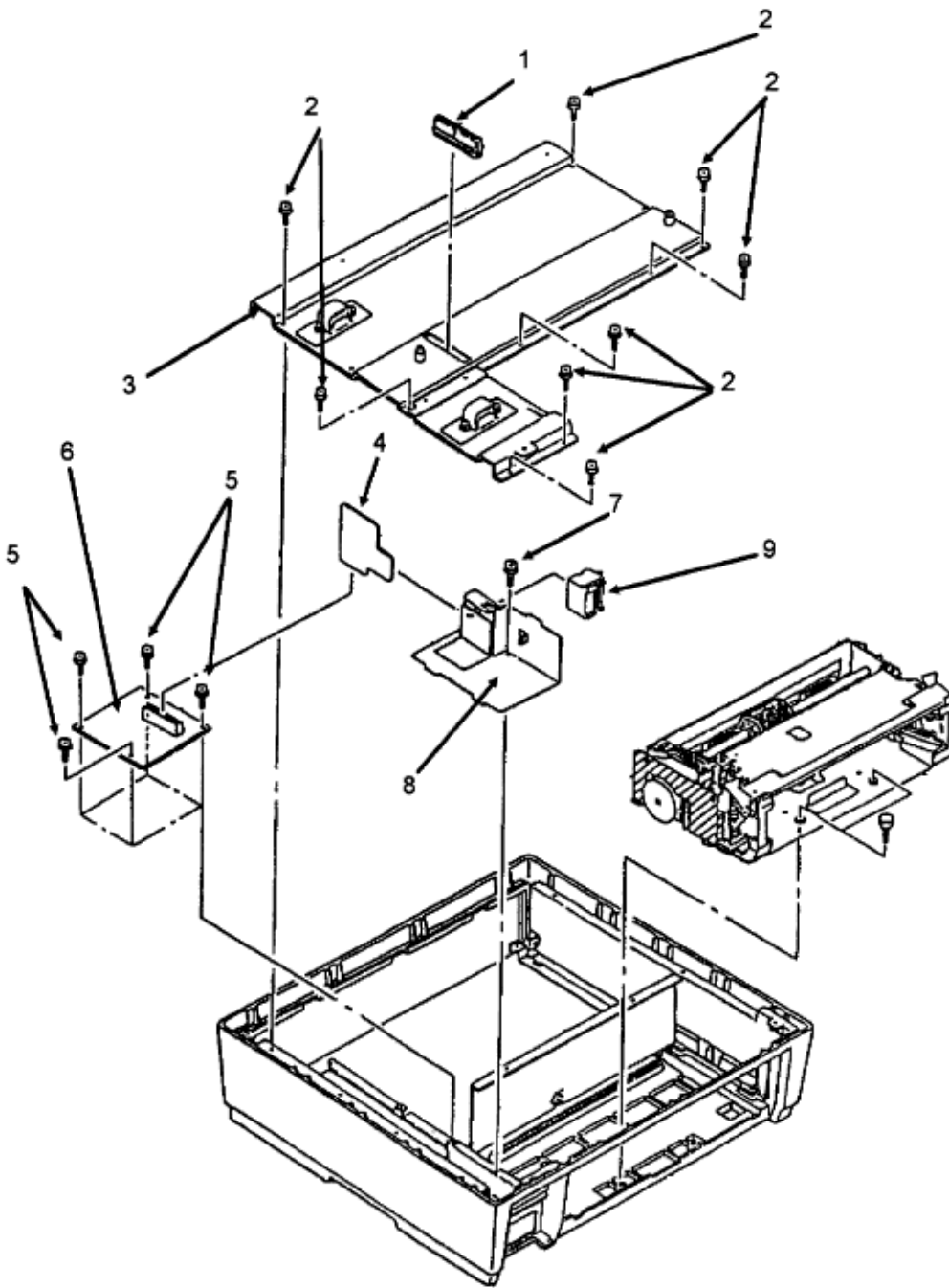

Copyright 1997, Okidata, Division of OKI America, Inc. All rights reserved. See the OKIDATA Business Partner Exchange (BPX) for any updates to this material. (<http://bpx.okidata.com>)

3.2.39 Second Paper Supply Unit (Option)

1. Perform these procedures: 3.2.01 and 3.2.37.
2. Remove the front panel (1).
3. Remove the two screws (2).
4. Press the paper supply unit release lever (3) down.
5. Remove the second paper supply unit (4).

P/N 50063501 Second Paper Supply Unit Option RSPL B.2.12 and 14

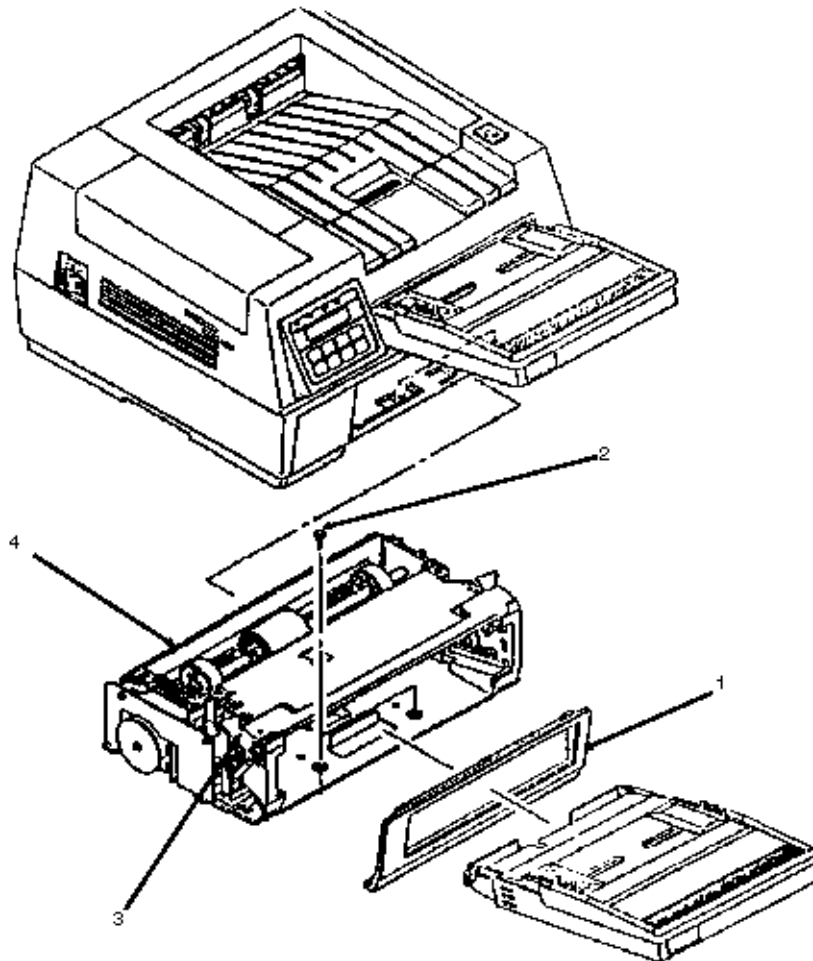

Copyright 1997, Okidata, Division of OKI America, Inc. All rights reserved. See the OKIDATA Business Partner Exchange (BPX) for any updates to this material. (<http://bpx.okidata.com>)

3.2.40 Cassette Spring (Second Paper Supply Unit)

1. Perform these procedures: 3.2.01, 3.2.37, and 3.2.39.
2. Raise the latch lever (1).
3. Remove the cassette spring (2).

Installation

When installing the cassette spring, keep the latch lever pressed down and the cassette set lever (3) pushed up. After the cassette spring is installed, press the cassette set lever down.

P/N 50917001 Spring: Cassette RSPL B.2.14

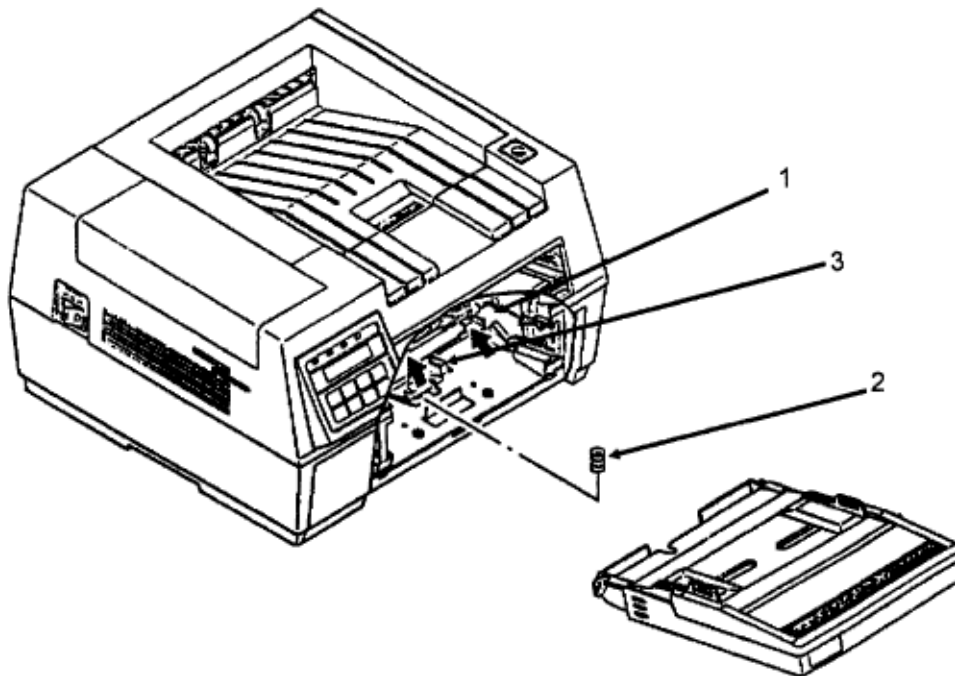

3.2.41 Registration Motor (Second Paper Supply Unit)

1. Perform these procedures: 3.2.01, 3.2.37, and 3.2.39.
2. Remove the two screws (1) and detach the pulse motor (2), being careful not to damage the pins.

Installation

Set the pulse motor on the bracket (3). Be careful not to scrape the pins against the LLFC Circuit Board (4).

Check that the pins of the pulse motor are securely in contact with the LLFC Circuit Board. Then, attach the pulse motor with the two screws.

P/N 56507401 Motor: Pulse (Registration) B.2.14

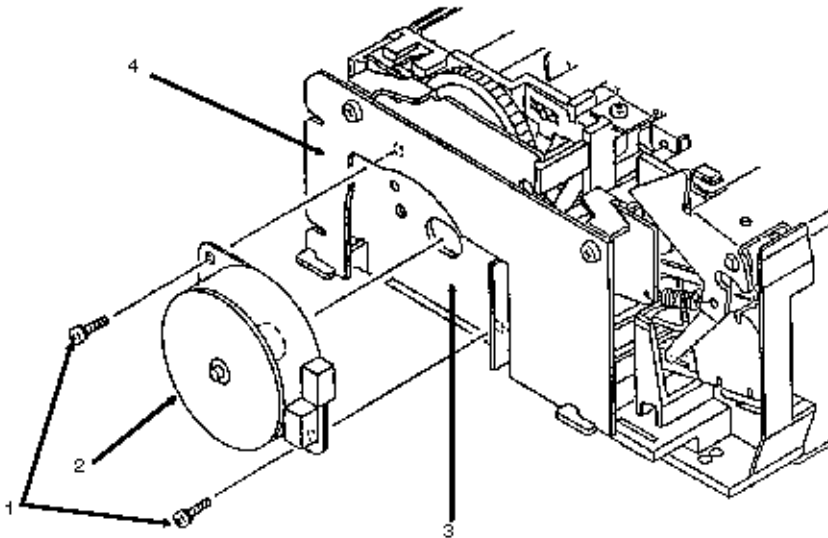

3.2.42 Second Paper Supply Unit Control Board, LLFC

1. Perform these procedures: 3.2.01, 3.2.37, and 3.2.39.
2. Remove the two screws (1).
3. Remove the second paper supply unit control board (2) from the guides (3).

P/N 55051401 PCB: LLFC (2nd Tray) Option RSPL B.2.12 and 14

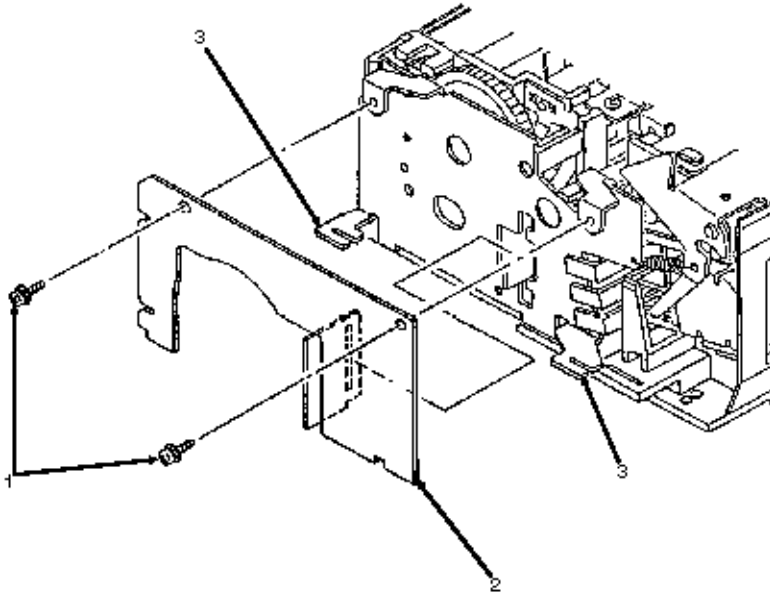

3.3 ADJUSTMENTS AND SERVICE SETTINGS

General Information

This section contains the procedures for resetting counters and performing adjustments and service settings. These procedures may be required when replacing either consumables or parts. The disassembly/assembly procedures list the required adjustments and refer you to this section. Failure to perform these procedures may result in unnecessary service calls.

There are three modes available to the service technician.

- Maintenance Mode
- System Maintenance Mode
- Switch 1 Maintenance Mode

Some adjustments and service settings are accomplished through Switch 1 (SW1) on the engine controller board. SW1 accesses the addresses on the EEPROM located on the engine controller board.

3.3.01 Drum Counter Reset

The drum counter is stored in EEPROM Address 2.

Reset the drum counter when a new image drum is installed.

The drum counter is reset through the operator panel.

1. Power OFF the printer.
2. Press and hold the MENU 1 / Menu 2 switch while powering ON the printer.
3. The message MAINTENANCE MODE will be displayed on the operator panel.
4. Press the MENU 1 / Menu 2 switch three times.
5. The message DRUM COUNT RESET will be displayed on the operator panel.
6. Press the ENTER / Quiet switch.
7. The messages listed below will be displayed.

DRUM COUNT RESET

RESETTING

INITIALIZING

WARMING UP

ON-LINE

8. The printer will initialize and return to an ON-LINE condition.

NOTE:

The CHANGE DRUM message will appear on the operator panel display when the image drum reaches 90% of its life. If a new image drum is installed, but the counter is not reset, the message will continue to be displayed.

3.3.02 Darkness Control

The Darkness Control Setting is stored in EEPROM Address 10.

It is adjusted from the Level 2 MENU. This adjustment changes the degree of character density.

The default value is 0. You may choose between -2, -1, 0, +1, and +2.

The setting for Darkness Control does not change when the printers emulation is changed.

1. Place the printer OFF-LINE.
2. Press the MENU 1 / Menu 2 switch and hold it in for more than 2 seconds.
3. The first MENU category of the Level 2 MENU will appear on the display.
4. Press the MENU 1 / Menu 2 switch until the word "Darkness" appears on the display.
5. Press the NEXT / + switch to toggle the values until the desired setting is reached.
6. Press ENTER / Quiet to store the new setting.

3.3.03 Switch 1 Maintenance Mode

Some adjustments and service settings are accomplished through the operator panel. Others are accomplished through Switch 1 (SW1) on the engine controller board. SW1 accesses the addresses on the EEPROM located on the engine controller board.

To perform procedures which use SW1, setup the printer for maintenance mode.

1. Press the OPEN switch and raise the stacker cover.
2. Press the two lock levers and open the LED holder.
3. Lift and remove the image drum cartridge. To protect the image drum cartridge, place it back in its styrofoam shipping package.
4. Close the LED holder.
5. Press the lock lever and raise the upper unit.
6. Override the cover open switch (1).
7. Power ON the printer while pressing SW1 (2) on the engine controller board.
8. The LED (3) will flash once, then pause. The LED will continue to flash once, then pause. This indicates that the printer is in Parameter 1 of the maintenance mode.

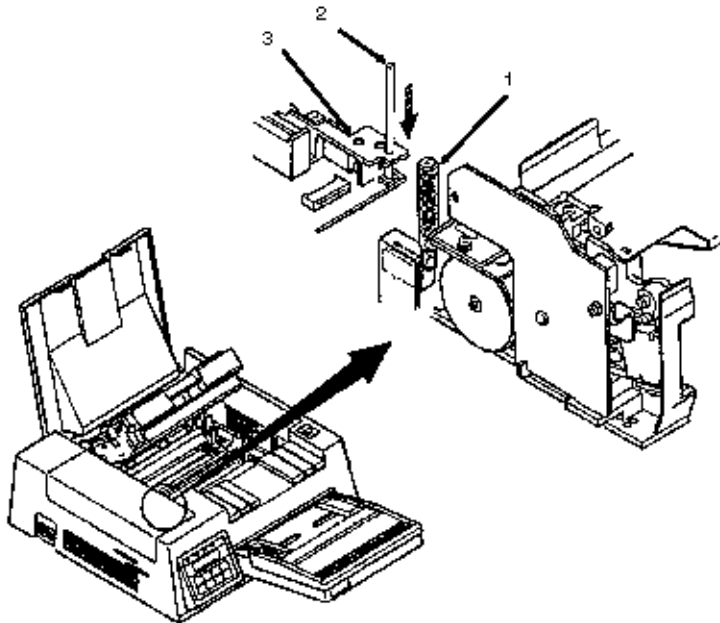

Copyright 1997, Okidata, Division of OKI America, Inc. All rights reserved. See the OKIDATA Business Partner Exchange (BPX) for any updates to this material. (<http://bpx.okidata.com>)

Actual Page Count

NOTE:

The actual page count cannot be changed.

The Actual Page Count is stored in EEPROM Address 1.

The Actual Page Counter counts the number of sheets printed by the printer.

The value of the Actual Page Counter will be displayed as follows:

1. Setup the printer for Switch 1 Maintenance Mode.
2. Press Switch 1 for five seconds.
3. The LED will display the contents of the Parameter 1 (Actual Page Counter) register.

The long flash indicates start of count.

Short flashes indicate counter contents (most significant digit first).

Ten flashes = 0.

There will be a pause between digits.

Upon completion of the count, a long flash will indicate start of count.

This process will loop until you press Switch 1 for five seconds. This will cause the Modified Page Count to be displayed.

4. Press Switch 1 for one second.
5. Power OFF the printer.

Actual Page Count Example

The Actual Page Count = 235 pages.

Switch 1 Action	LED Display	Description
Press at Power ON	Flashes ON/OFF	Parameter 1 selected
Press for 5 seconds	Long Flash	Start of Count
None	On-Off-On-Pause	1st Digit = 2

None	On-Off-On-Off-On-Pause	2nd Digit = 3
None	On-Off-On-Off-On-Off-On-Off-On-Pause	3rd Digit = 5
None	Long Flash	Start of Count
Press for 5 seconds	Long Flash	Start of Modified Page Count

Copyright 1997, Okidata, Division of OKI America, Inc. All rights reserved. See the OKIDATA Business Partner Exchange (BPX) for any updates to this material. (<http://bpx.okidata.com>)

Modified Page Count

NOTE:

The Modified Page Count cannot be changed.

To access the Modified Page Count, you must first view the Actual Page Count.

The Modified Page Count is stored in EEPROM Address 1, after the Actual Page Count.

The Modified Page Counter combines the main motor revolution time and the number of printed sheets. Drum replacement is determined by the Modified Page Count. The Modified Page Count considers the type of printing being performed. For example, if the printer performs many single page print jobs, the Modified Page Count will be greater than the Actual Page Count.

The value of the Modified Page Count will be displayed as follows.

1. Setup the printer for Switch 1 Maintenance Mode.
2. View the Actual Page Count.
3. Press Switch 1 for five seconds.
4. The LED will display the contents of the Parameter 1 (Modified Page Count) register.

The long flash indicates start of count.

Short flashes indicate counter contents (most significant digit first).

Ten flashes = 0.

There will be a pause between digits.

Upon completion of the count, a long flash will indicate start of count.

This process will loop until you press Switch 1.

5. To end this procedure, press Switch 1 for 1 second.
6. The LED will perform one short flash to indicate Parameter 1 is selected.
7. Power OFF the printer.

Modified Page Count Example

The Modified Page Count = 142 pages.

Switch 1 Action	LED Display	Description
The first step in this table is also the last step in the Actual Page Counter Example Table		
Press for 5 seconds	Long Flash	Start of Modified Page Count
None	On-Pause	1st Digit = 1
None	On-Off-On-Off-On-Off-On-Pause	2nd Digit = 4
None	On-Off-On-Pause	3rd Digit = 2
None	Long Flash	Start of Count

Copyright 1997, Okidata, Division of OKI America, Inc. All rights reserved. See the OKIDATA Business Partner Exchange (BPX) for any updates to this material. (<http://bpx.okidata.com>)

Fuser Counter Reset

The fuser counter is stored in EEPROM Address 3.

This counter should be reset when a new fusing unit is installed.

Follow this procedure to reset the fuser counter.

1. Setup the printer for Switch 1 Maintenance Mode.
2. Press Switch 1 twice (one second each time) to access Parameter 3.
3. The LED will flash three times, indicating Parameter 3.
4. Press Switch 1 once for five seconds.
5. The LED will display the contents of Parameter 3.

The long flash indicates start of count.

Short flashes indicate counter contents (most significant digit first).

Ten flashes = 0.

There will be a pause between digits.

Upon completion of the count, a long flash will indicate start of count.

This process will loop until you press Switch 1.

6. Press Switch 1 for five seconds. This will reset the counter to zero.
7. To end the adjustment, press Switch 1 for five seconds.
8. The LED will flash three times, indicating Parameter 3.
9. Power OFF the printer.

Vertical Print Start Position Adjustment

The Vertical Printer Start Position is stored in EEPROM Address 9.

The Vertical Print Start Position Adjustment is used to set the top of form position. Use this adjustment to correct print start variations between different printers, or to achieve 4.6 mm Vertical Print Start Position, the default value. The default value is stored in the EEPROM Parameter 0 of the EEPROM Address 9.

Follow this procedure to change the Vertical Print Start Position.

1. Setup the printer for Switch 1 Maintenance Mode.
2. Press Switch 1 eight times (one second each time) to access Parameter 9.
3. The LED will flash nine times, indicating Parameter 9.
4. Press Switch 1 once for five seconds.
5. The LED will display the contents of Parameter 9.

The long flash indicates start of count.

Short flashes indicate counter contents (most significant digit first).

Ten flashes = 0.

There will be a pause between digits.

Upon completion of the count, a long flash will indicate start of count.

This process will loop until you press Switch 1.

6. Press Switch 1 for X times.

X = the increments needed to move from the stored parameter contents to the desired parameter.

To move from the default value of 0 (0 Parameter) to -0.5 millimeter (Parameter 15), press Switch 1 fifteen times.

7. To end the adjustment, press Switch 1 for five seconds.
8. The LED will flash nine times, indicating Parameter 9.
9. Power OFF the printer.

Copyright 1997, Okidata, Division of OKI America, Inc. All rights reserved. See the OKIDATA Business Partner Exchange (BPX) for any updates to this material. (<http://bpx.okidata.com>)

Chart of EEPROM Parameters and Print Start Positions

0 follows 15 when incrementing through the parameters.

EEPROM Parameter	Print Start Position
	(in millimeters)
0	+/- 0.0
1	+ 0.5
2	+1.0
3	+1.5
4	+2.0
5	+2.5
6	+3.0
7	+3.5
8	-4.0
9	-3.5
10	-3.0
11	-2.5
12	-2.0
13	-1.5
14	-1.0
15	-0.5

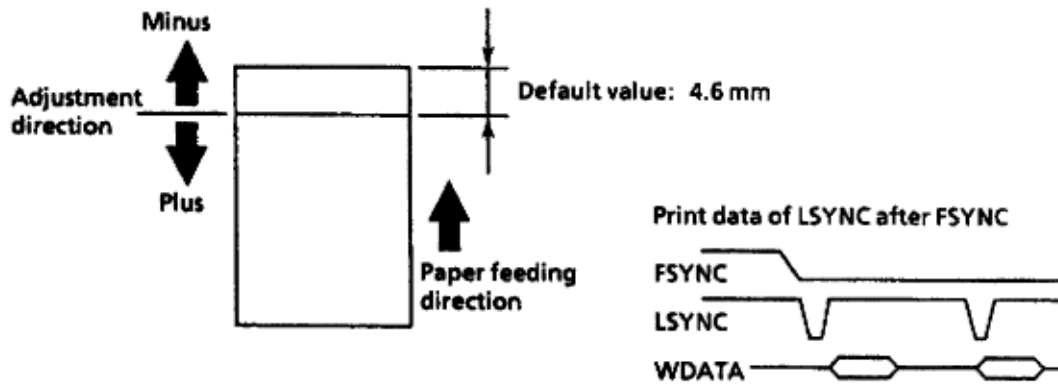

Copyright 1997, Okidata, Division of OKI America, Inc. All rights reserved. See the OKIDATA Business Partner Exchange (BPX) for any updates to this material. (<http://bpx.okidata.com>)

Setting the LED Head Drive Time

The LED Head Drive Time setting is stored in EEPROM Address 13.

This adjustment may need to be performed when an LED head is replaced. However, if the luminous energy ratings of the new and original LED Heads are the same, adjustment is not necessary. The luminous energy rating is on the label on the LED Head. The third and second digits, reading from the right, are the drive time rating.

Follow this procedure to change the LED Head Drive Time.

1. Setup the printer for Switch 1 Maintenance Mode.
2. Press Switch 1 twelve times (one second each time) to access Parameter 13.
3. The LED will flash thirteen times, indicating Parameter 13.
4. Press Switch 1 once for five seconds.
5. The LED will display the contents of Parameter 13.

The long flash indicates start of count.

Short flashes indicate counter contents (most significant digit first). Ten flashes = 0.

There will be a pause between digits.

Upon completion of the count, a long flash will indicate start of count.

This process will loop until you press Switch 1.

6. Press Switch 1 for X times. X = the increments needed to move from the stored parameter contents to the desired parameter. The moves are made in increments.
7. To end the adjustment, press Switch 1 once for five seconds.
8. The LED will flash thirteen times, indicating Parameter 13.
9. Power OFF the printer.
10. Perform a Continuous Print Test. If the print quality is not satisfactory, reset the drive time to the parameter immediately before or after the value just set. Determine which parameter is appropriate by comparing print samples.

CAUTION:

The OL810 printhead should not be used in non-OST Okidata printers.

The barcoded intensity rating label on the upper left side of the LED head will tell you which LED head you are working with. A designation of 300T supports OST. A designation of 300S does not support OST.

When replacing the OL810 LED head, you must install an LED head with OST capability. If you install a standard (non-OST) LED head, the printer will not function properly. A "mirror image" of the desired data will print. The printer will print "mirror images", regardless of the Smoothing Setting in the Level 2 menu.

Chart of LED Head Drive Time Settings

NOTE:

0 follows 15 when incrementing between parameters.

Luminous Intensity Rating on LED Head	Drive Time Setting (Parameter)
14 and 15	0
12 and 13	1
11	2
10	3
	4
	5
30	10
26 to 29	11
23 to 25	12
20 to 22	13
18 and 19	14
16 and 17	15

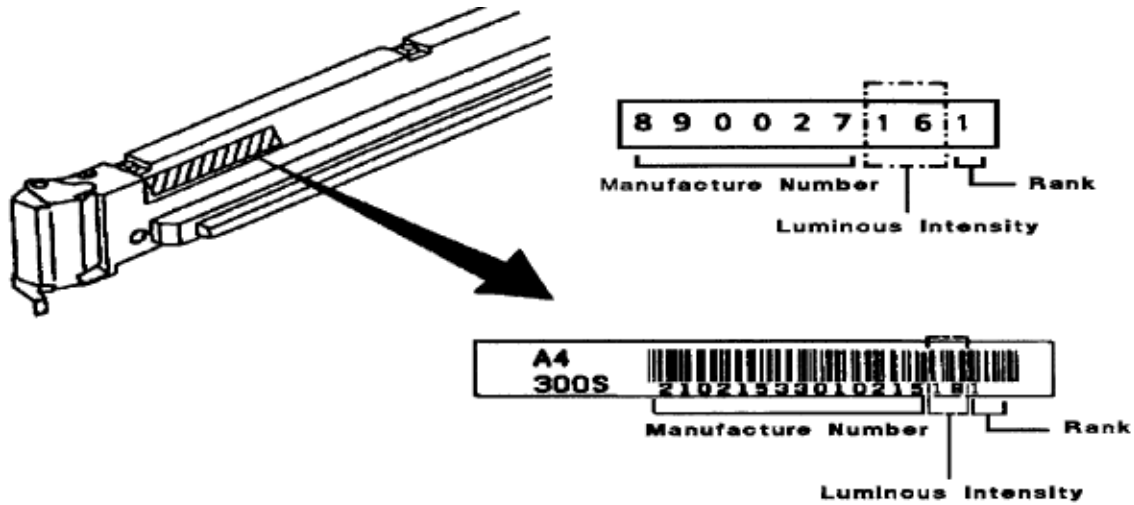

Copyright 1997, Okidata, Division of OKI America, Inc. All rights reserved. See the OKIDATA Business Partner Exchange (BPX) for any updates to this material. (<http://bpx.okidata.com>)

3.3.04 Smoothing Select

The Smoothing Select setting is stored in EEPROM Address 11.

Smoothing may be set ON or OFF. The default value is ON. With Smoothing ON, the printer utilizes Okidata Smoothing Technology (OST).

1. Place the printer OFF-LINE.
 2. Press and hold the LAST - / Smoothing switch.
 3. Use either LAST - or NEXT + to toggle between the settings ON and OFF.
 4. Press ENTER / Quiet to save your selection.
 5. The printer will go ON-LINE.
-

Copyright 1997, Okidata, Division of OKI America, Inc. All rights reserved. See the OKIDATA Business Partner Exchange (BPX) for any updates to this material. (<http://bpx.okidata.com>)

3.3.05 DC Voltage Check (+5 vdc)

NOTE:

You can check the voltage level, but it cannot be adjusted.

1. Remove the upper cover.
2. Remove the image drum cartridge.
3. Remove the paper supply unit.
4. Remove the engine controller circuit board (LLAB-2).
5. Remove the main motor assembly.
6. Use a digital multimeter which has an input impedance of 10 Mohms and is capable of displaying to the second decimal place or farther.
7. Check the voltage at CN1 of the interconnect board between Pin 31, 5V and Pin 27, 0V
8. The value should be + 5.0 vdc (+/- 0.1)

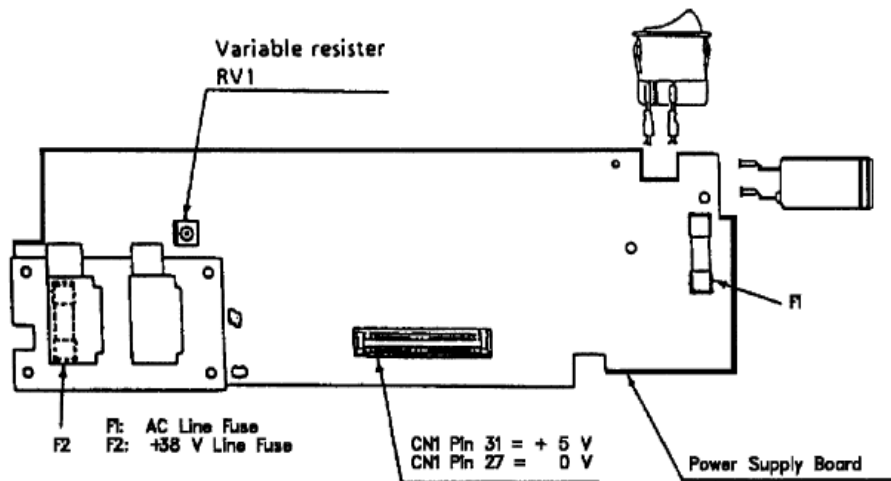

3.3.06 Menu Operation

NOTE:

Using the commands sent from the computer will override the features set in the menu. However, when the printer is powered OFF, features set by this method will be canceled. Features set in the menu will stay in effect, even when the printer is powered OFF.

General Information

Menu Mode allows customization of printer settings and features. Selections made are stored in the printers EEPROM. However, they can be changed through software commands or by resetting the menu.

The Menu is made up of a number of Categories.

Each Category has a list of Settings.

Current Settings are indicated with an asterisk (*).

Refer to the Printer Handbook for a full explanation of menu selections.

Menu Mode

1. Verify that the printer is ON-LINE. The READY light is lit.
2. Press ON-LINE to place the printer OFF-LINE. The READY light IS NOT lit.
3. To access the desired menu, follow one of the steps listed below.

For the Primary Menu, press and release MENU 1.

For the Secondary Menu, press and hold MENU 1 / Menu 2 for more than two seconds.

4. The first menu category will appear on the operator panel display.
5. To move between categories, press MENU 1 / Menu 2.
6. Each category has several possible settings.

To view the settings, follow either of the steps listed below.

Press NEXT + / Demo to view the next setting.

Press LAST - / Smoothing to view the previous setting.

7. When the desired setting is displayed, press ENTER to store the setting.

Current settings are displayed with an ASTERISK (*).

8. To exit Menu Mode, press RESET.

Printing the Menu

The Menu Print can provide the following information to the service technician.

- Program ROM Revision Level (CU and PU)
- Font ROM Revision Level
- Amount of Printer Page Memory
- Factory Menu Settings
- User Selected Menu Settings

Printing the Menu provides a reference of current menu settings.

This will help you move through the menu.

Okidata STRONGLY RECOMMENDS printing the Menu *before* resetting the Menu to factory defaults.

Once the Menu is reset, all customized settings are LOST.

To print the Menu, follow these steps.

1. Power ON the printer and wait for the printer to go ON-LINE.
2. Press the ON-LINE switch to take the printer OFF-LINE.
3. Press the PRINT FONTS/*Print Menu* switch for 3 seconds.
4. The DATA lamp will turn ON, the READY lamp will flash and the message MENU PRINT will be displayed on the operator panel.
5. The Menu will print.
6. When printing is completed, the printer will be OFF-LINE. Press the ON-LINE switch to place the printer ON-LINE.

Sample

OL810 LED PAGE PRINTER

Program ROM : CU 01.92 A00 PU 00.07 FONT 00.16
Page Memory : 4M Bytes Installed

Operator Panel Menu Settings**Level-1**

Common	Factory	User
EMULATION	HP LJ III	HP LJ III
COPIES	1	1
PAPER FEED	TRAY1	TRAY1
AUTO TRAY SWITCH	OFF	OFF
TRAY1 PAPER SIZE	UNIVERSAL=A4	UNIVERSAL=A4
TRAY2 PAPER SIZE	UNIVERSAL=A4	UNIVERSAL=A4
HP LaserJet III Emulation		
ORIENTATION	PORTRAIT	PORTRAIT
FONT SOURCE	RESIDENT	RESIDENT
FONT No.	1000	1000
SYMBOL SET	Roman-8	Roman-8
HP CARTRIDGE	NONE	NONE
LINES PER PAGE	60 LINES	60 LINES
A4 PRINT WIDTH	78 COLUMN	78 COLUMN

Level-2

SMOOTHING	ON	ON
PAGE PROTECTION	OFF	OFF
HOST INTERFACE	PARALLEL	RS232C
FLOW CONTROL	DTR HI POLARITY	DTR HI POLARITY
BAUD RATE	9600 BAUD	19200 BAUD
DATA BITS	8 BITS	7 BITS
PARITY	NONE	EVEN
MIN.BUSY TIME	200mSEC	200mSEC
DARKNESS	0	+2
TIME TO QUIET	8 MINUTES	8 MINUTES
AUTO CONTINUE	OFF	OFF
LEGAL LENGTH	14 INCH	14 INCH
LANGUAGE	ENGLISH	ENGLISH

Copyright 1997, Okidata, Division of OKI America, Inc. All rights reserved. See the OKIDATA Business Partner Exchange (BPX) for any updates to this material. (<http://bpx.okidata.com>)

Reset Menu to Factory Defaults

CAUTION:

Once the menu has been reset, all customized menu settings will be lost.

Always print the menu before resetting the printer to factory defaults.

To reset the menu to factory default settings, follow this procedure.

1. Power OFF the printer.
2. Press and hold MENU 1 / Menu 2 while powering ON the printer.
Continue to hold MENU 1 / Menu 2 until MAINTENANCE MODE is displayed on the operator panel.
3. Press MENU 1 / Menu 2.
4. Press ENTER / QUIET.

Copyright 1997, Okidata, Division of OKI America, Inc. All rights reserved. See the OKIDATA Business Partner Exchange (BPX) for any updates to this material. (<http://bpx.okidata.com>)

Menu Settings

Primary Menu - HP LaserJet III Emulation

Factory default settings are printed in ***Bold Italic***.

Selections marked with an asterisk (*) appear ONLY when an option is installed.

Category	Selection	Explanation
Emulation	<i>HP LJ III</i> IBM PPR III XL	Change Emulation
Copies	<i>01</i> to 99	Select the number of copies to print by cycling through the numbers with the NEXT + and LAST - buttons.
Paper Feed	<i>Tray 1</i> Tray 2 * Manual Feed	Select whether paper will be fed from the upper paper tray (Tray 1) the optional lower paper tray (Tray 2) or the manual feed tray.
Auto Tray Switch *	<i>Off</i> On	Automatically switch to the lower tray when the upper tray is empty. This feature is active ONLY when the optional lower tray is installed.
Tray 1 Paper Size *		Select paper / envelope size when the optional universal paper tray or envelope tray is installed as Tray 1.
	Universal = LETTR	
	Universal = Exec	
	<i>Universal = A4</i>	A4 = 210 x 297 millimeters
	Universal = A5	A5 = 148 x 210 millimeters
	Universal = A6	A6 = 105 x 148 millimeters
	Universal = B5	B5 = 182 x 257 millimeters
	Envelope = COM10	COM10 = 4.12 x 9.5 inches
	Envelope = MONRC	MONRC = 3.87 x 7.5 inches
	Envelope = DL	DL = 111 x 223 millimeters

	Envelope = C5	CF = 163 x 234 millimeters
Tray 2 Paper Size *		This feature displays ONLY when the optional second paper tray is installed.
		DO NOT feed envelopes from Tray 2.
	Universal = LETTR	
	Universal = Exec	
	Universal = A4	A4 = 210 x 297 millimeters
	Universal = A5	A5 = 148 x 210 millimeters
	Universal = B5	B5 = 182 x 257 millimeters
Orientation	Portrait or Landscape	Select the direction of print on the paper.
		Portrait printing is normal printing across the width of the paper.
		Landscape printing prints across the length of the paper.

Factory default settings are printed in **Bold Italic**.

Selections marked with an asterisk (*) appear ONLY when an option is installed.

Category	Selection	Explanation
Font Source	Resident Upper Card * Lower Card * Downloaded *	<i>This specifies whether the default is the internal (resident) font set a font card or a downloaded set.</i>
		<i>Card and Downloaded selections appear ONLY if these options are installed in the printer.</i>
Font Number	1000	Select the default font by identification number from the available fonts based on selected orientation and font source.
		The prefix indicates the font source.
		I = Internal (Resident)
		U = Upper Card
		L = Lower Card
		S = Soft (Downloaded)
		Refer to the Font Print Sample.
Symbol Set	Roman-8	Select the default symbol set.

		Roman-8 is the standard Hewlett-Packard set.
		Many other special purpose sets are available.
		Refer to Appendix C in the Printer Handbook for a comprehensive list of symbol sets.
HP Cartridge	None F B	These are Hewlett-Packard Font cartridge designations.
		When printing documents formatted for the OL400 verify that this setting works with the software. Otherwise use the default setting NONE.
Line Per Page	60 Lines 5 to 128 Lines	
A4 Print Width	78 column 80 column	A4 paper is slightly narrower than standard letter size.
		Eighty 10-pitch characters WILL NOT fit in the printable area of an A4 page.
		When this selection is set to 80 column the printer condenses the characters slightly so that 80 characters will fit on a line.

Menu Settings

Primary Menu - IBM ProPrinter III XL Emulation

Factory default settings are printed in ***Bold Italic***.

Selections marked with an asterisk (*) appear ONLY when an option is installed.

Category	Selection	Explanation
Copies	01 to 99	Select the number of copies to print by cycling through the numbers with the NEXT + and LAST - buttons.
Paper Feed	Tray 1 Tray 2 * Manual Feed	Select whether paper will be fed from the upper paper tray (Tray 1) the optional lower paper tray (Tray 2) or the manual feed tray.
Auto Tray Switch *	Off On	Automatically switch to the lower tray when the upper tray is empty. This feature is active ONLY when the optional lower tray is installed.
Tray 1 Paper Size *		Select paper / envelope size when the optional universal paper tray or envelope tray is installed as Tray 1.
	Universal = LETTR	
	Universal = Exec	
	Universal = A4	A4 = 210 x 297 millimeters
	Universal = A5	A5 = 148 x 210 millimeters
	Universal = A6	A6 = 105 x 148 millimeters
	Universal = B5	B5 = 182 x 257 millimeters
	Envelope = COM10	COM10 = 4.12 x 9.5 inches
	Envelope = MONRC	MONRC = 3.87 x 7.5 inches
	Envelope = DL	DL = 111 x 223 millimeters
	Envelope = C5	CF = 163 x 234 millimeters

Tray 2 Paper Size *		This feature displays ONLY when the optional second paper tray is installed.
		DO NOT feed envelopes from Tray 2.
	Universal = LETTR	
	Universal = Exec	
	Universal = A4	A4 = 210 x 297 millimeters
	Universal = A5	A5 = 148 x 210 millimeters
	Universal = B5	B5 = 182 x 257 millimeters
Orientation	Portrait or Landscape	Select the direction of print on the paper.
		Portrait printing is normal printing across the width of the paper.
		Landscape printing prints across the length of the paper.

Factory default settings are printed in **Bold Italic**.

Selections marked with an asterisk (*) appear ONLY when an option is installed.

Category	Selection	Explanation
Character Pitch	10 12 17 20 CPI Proportional	Choose the number of characters per inch.
Font Style	Normal Emphasize Italic	
Enlarge Font	Height x 1 Width x 1 Height x 2 Width x 1 Height x 1 Width x 2 Height x 2 Width x 2	Choose the parameters to enlarge the current font.
Character Set	Set 1 Set 2	Choose between IBM Character Sets 1 and 2.
Symbol Set	IBM-437	There are many symbol sets to choose from.
		Refer to Appendix C in the Printer Handbook for a comprehensive list.
Line Length	80 column 136 column	Choose the line length.
Form Length	11 inch (Letter) 11.7 inch (A.4) 12 inch	Choose the paper size for the current tray.
Auto CR / LF	CR = CR LF = LF CR = CR + LF LF = CR + LF CR = CRLF LF = CRLF	

Form Feed at TOF	Feed Enable Feed Disable	Turn the form feed feature on or off.
Font Condense	12 cpi to 20 cpi 12 cpi to 12 cpi	
Zero Style	Without Slash With Slash	Choose a slashed or unslashed zero.
Slash Letter O	Disable Enable	Choose a slashed or unslashed letter O.

Copyright 1997, Okidata, Division of OKI America, Inc. All rights reserved. See the OKIDATA Business Partner Exchange (BPX) for any updates to this material. (<http://bpx.okidata.com>)

Menu Settings

Secondary Menu - Both Emulations

Factory default settings are printed in ***Bold Italic***.

Selections marked with an asterisk (*) appear ONLY when an option is installed.

Category	Selection	Explanation
Smoothing	<i>On</i> Off	<i>Turn OKI Smoothing Technology ON or OFF.</i>
<i>Page Protection</i> *	<i>Off</i> Letter Legal A4	This feature IS NOT active unless the optional memory is installed. Choose the type of paper you are using.
Host Interface	<i>Parallel</i> RS232C *	
I-PRIME	<i>Off</i> On	This choice displays ONLY if a parallel interface is being used.
Flow Control *	<i>DTR Hi Polarity</i> DTR Lo Polarity SSD Hi Polarity SSD Lo Polarity XON / XOFF	This choice displays ONLY if the optional serial interface is being used.
Baud Rate RS232 *	<i>9600</i> 19200	This choice displays ONLY if the optional serial interface is being used.
Data Bits RS232 *	<i>8 bits</i> 7 bits	This choice displays ONLY if the optional serial interface is being used.
Parity RS232 *	<i>None</i> Even Odd	This choice displays ONLY if the optional serial interface is being used.
Min. Busy RS232 *	<i>200 ms</i> 1 second	This choice displays ONLY if the optional serial interface is being used.
Robust XON RS232 *	<i>Off</i> On	This choice displays ONLY if the optional serial interface is being used.
Darkness	- 2 - 1 <i>0</i> 1 2	Controls the density of the print.

Time to Quiet	8 minutes 1 minute Disable	Set the time to wait before entering Quiet Mode.
Auto Continue	Off On	Choose ON if you want the printer to continue after an error.
Legal Length	14 inches 13 inches	Select the type of legal paper being used.
Language	English Deutch (German) Francais (French) Italiano (Italian) Castellano (Spanish)	Select the language for the Menu.

Copyright 1997, Okidata, Division of OKI America, Inc. All rights reserved. See the OKIDATA Business Partner Exchange (BPX) for any updates to this material. (<http://bpx.okidata.com>)

3.3.07 Key Combinations

Key Combinations	Description
MENU 1 / Menu 2 (Hold during power ON until MAINTENANCE MODE is displayed on the operator panel)	Access the Maintenance Mode.
RECOVER / Reset (Hold during power ON until SYS. MAINTENANCE is displayed on the operator panel)	Access the System Maintenance Mode. The end user SHOULD NOT access this mode.
	Press MENU 1 / Menu 2 to move between the four settings.
	Paper Count
	Displays the total number of pages printed as calculated by the engine
	section.
	Refer to Section 3.3 of this Service Handbook.
	To exit power OFF the unit.
	Continuous Print
	Activates the Continuous Print (Rolling ASCII) Test.
	Refer to Section 4.8 of this Service Handbook.
	To exit power OFF the unit. To exit power OFF the unit.
	Loop Test
	Activates the Serial Interface Loopback Test
	Refer to Section 4.8 of this Service Handbook.
	To exit power OFF the unit. To exit power OFF the unit.
	EEPROM Reset
	Resets <i>all</i> menu settings (Menu 1 <i>and</i> Menu 2) to factory defaults.

	Refer to Section 3.3 of this Service Handbook.
	To exit power OFF the unit. To exit power OFF the unit.
	Press ENTER / Quiet to access the setting options.
MENU 1 / Menu 2 (Hold while printer is OFF-LINE until MENU MODE message is displayed on the operator panel)	Access the primary menu (Menu 1)
MENU 1 / Menu 2 (Hold while printer is OFF-LINE [more than two seconds] until MENU 2 MODE message is displayed on the operator panel)	Access the secondary menu (Menu 2)

Copyright 1997, Okidata, Division of OKI America, Inc. All rights reserved. See the OKIDATA Business Partner Exchange (BPX) for any updates to this material. (<http://bpx.okidata.com>)

3.3.08 Resets

Reset Menu to Factory Defaults

CAUTION:

Once the menu has been reset, all customized menu settings will be lost.

Always print the menu before resetting the printer to factory defaults.

To reset the menu to factory default settings, follow this procedure.

1. Power OFF the printer.

2. Press and hold MENU 1 / Menu 2 while powering ON the printer.

Continue to hold MENU 1 / Menu 2 until MAINTENANCE MODE is displayed on the operator panel.

3. Press MENU 1 / Menu 2.

4. Press ENTER / QUIET.

Reset the Drum Counter

The drum counter is stored in EEPROM Address 2.

Reset the drum counter when a new image drum is installed.

The drum counter is reset through the operator panel.

1. Power OFF the printer.

2. Press and hold the MENU 1 / Menu 2 switch while powering ON the printer.

3. The message MAINTENANCE MODE will be displayed on the operator panel.

4. Press the MENU 1 / Menu 2 switch three times.

5. The message DRUM COUNT RESET will be displayed on the operator panel.

6. Press the ENTER / Quiet switch.

7. The messages listed below will be displayed.

DRUM COUNT RESET

RESETTING

INITIALIZING

WARMING UP

ON-LINE

8. The printer will initialize and return to an ON-LINE condition.

NOTE:

The CHANGE DRUM message will appear on the operator panel display when the image drum reaches 90% of its life. If a new image drum is installed, but the counter is not reset, the message will continue to be displayed.

Reset the Fuser Counter

The fuser counter is stored in EEPROM Address 3.

This counter should be reset when a new fusing unit is installed.

Follow this procedure to reset the fuser counter.

1. Setup the printer for Switch 1 Maintenance Mode.
2. Press Switch 1 twice (one second each time) to access Parameter 3.
3. The LED will flash three times, indicating Parameter 3.
4. Press Switch 1 once for five seconds.
5. The LED will display the contents of Parameter 3.

The long flash indicates start of count.

Short flashes indicate counter contents (most significant digit first).

Ten flashes = 0.

There will be a pause between digits.

Upon completion of the count, a long flash will indicate start of count.

This process will loop until you press Switch 1.

6. Press Switch 1 for five seconds. This will reset the counter to zero.
 7. To end the adjustment, press Switch 1 for five seconds.
 8. The LED will flash three times, indicating Parameter 3.
 9. Power OFF the printer.
-

Copyright 1997, Okidata, Division of OKI America, Inc. All rights reserved. See the OKIDATA Business Partner Exchange (BPX) for any updates to this material. (<http://bpx.okidata.com>)

3.4 CLEANING

3.4.01 General Information

Routine inspection and cleaning should be performed every six months.

1. Remove any dropped toner and dust.
2. Clean inside and around the printer with a vacuum cleaner (designed to pick-up toner) when necessary.

CAUTION

If you use a vacuum cleaner that does not have a toner filter, you may severely damage the vacuum cleaner.

Cleaning Table

Item	Action	Disassembly Procedure
LED Lens Array	1.Clean the LED lens array when vertical white lines or stripes (voids and/or light printing) are present on printer output.	
	2.Use the LED lens cleaner provided in the image drum kit. or Use isopropyl alcohol (90%) and a clean cotton swab.	
	3.Place the LED head cleaner pad (or a cotton swab that has a small amount of alcohol on it) against the LED lens array.	
	4.Slide the cleaner pad (or swab) across the lens array several times to clean the head. Use a clean portion of the pad on each pass. DO NOT scrub or scratch the LED. If you are using a swab and alcohol DO NOT allow alcohol to spill or drip inside the printer on any components or onto the image drum.	
	5.Discard the used pad.	

Hopping Roller	Clean with ethyl alcohol.	
	Remember to clean the hopping roller on the second paper supply if installed.	
Registration Roller	Clean with ethyl alcohol.	
Pressure Roller	Clean with ethyl alcohol.	
Printer Unit	Clean the inside of the unit with a vacuum cleaner designed to handle toner. If you use a vacuum cleaner that does not have a toner filter you may severely damage the vacuum cleaner.	
Covers	Clean as needed. Use a soft clean cloth and a general purpose cleaner.	

Copyright 1997, Okidata, Division of OKI America, Inc. All rights reserved. See the OKIDATA Business Partner Exchange (BPX) for any updates to this material. (<http://bpx.okidata.com>)

3.4.02 Static Charger

Clean the static charger if vertical black lines, vertical black stripes, or toner blotching are present on printer output.

1. Power OFF the printer.
2. Press the OPEN switch raise the stacker cover.
3. Move the wire cleaner (1) of the image drum cartridge all the way to the left and then back to the right.

NOTE:

After the cleaning, be sure to return the wire cleaner to its original position. If you do not, a vertical black stripe will appear on printer output.

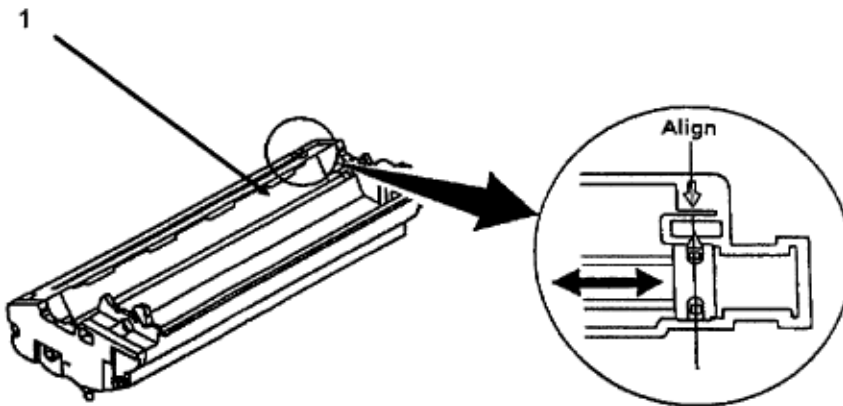
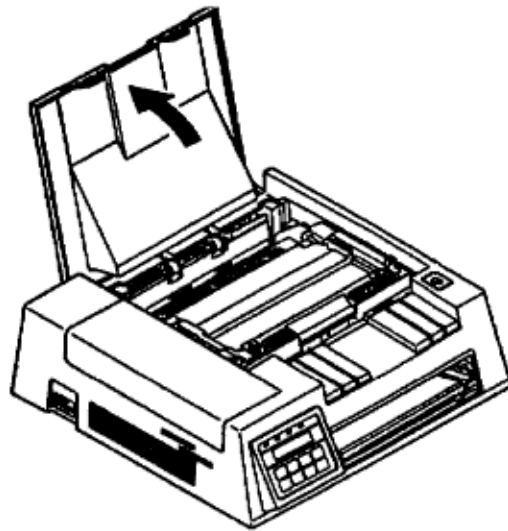
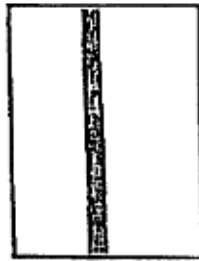

3.4.03 Transfer Charger

Clean the transfer charger if vertical white lines or stripes (printed lightly) are present on printer output.

1. Turn OFF the power supply switch.
2. Press the OPEN switch and raise the stacker cover.
3. Push the lock lever backward to lift the LED holder.
4. Remove out the wire cleaner (1).
5. Position the wire cleaner in the transfer charger assembly as shown in Figure A.
6. Slide the wire cleaner left and right several times across the wire. This cleans the transfer wire.

Do not press strongly when wiping or you will break the wire.

7. Return the wire cleaner to its storage clip.

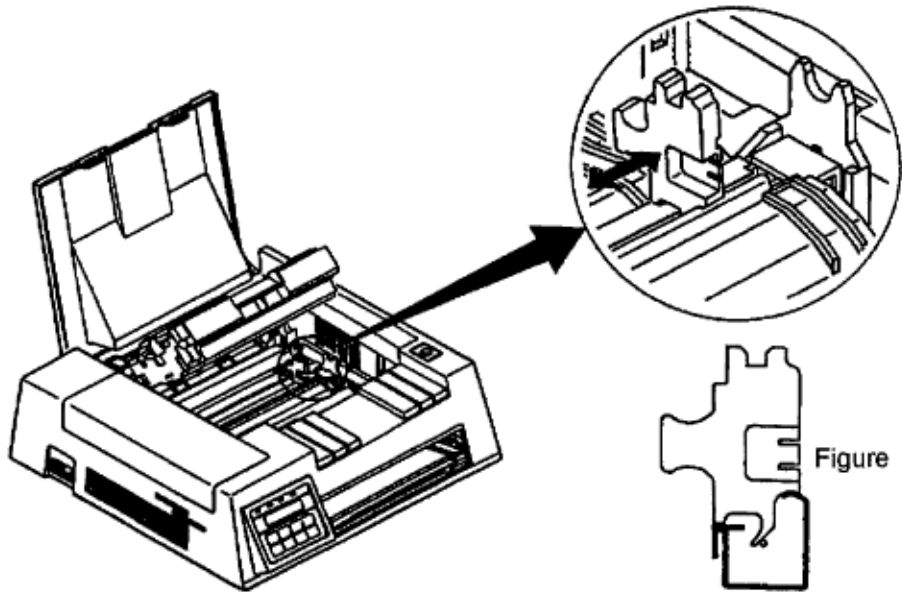
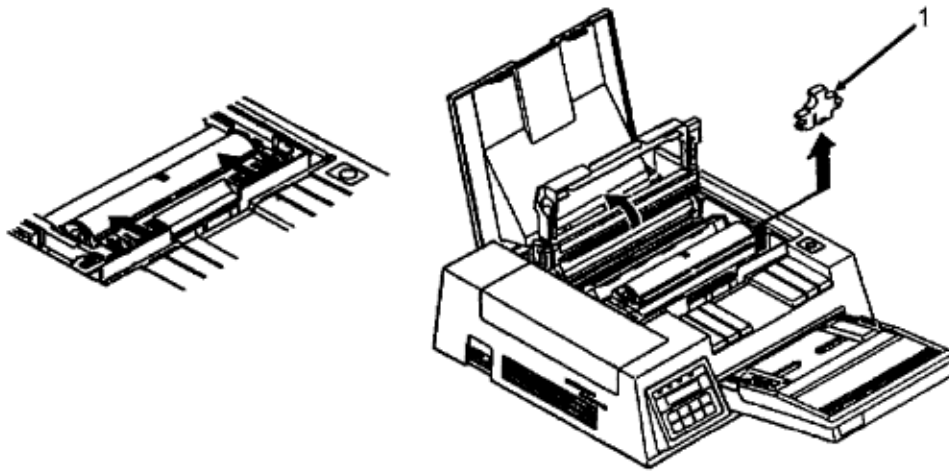
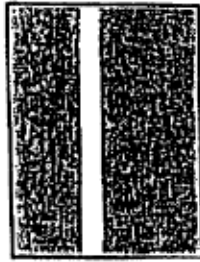

3.5 LUBRICATION

3.5.01 General Information

Silicon oil should be applied once a year to the gears.

Copyright 1997, Okidata, Division of OKI America, Inc. All rights reserved. See the OKIDATA Business Partner Exchange (BPX) for any updates to this material. (<http://bpx.okidata.com>)

3.6 SHIPPING INSTRUCTIONS

3.6.01 Return for Service

CAUTION:

When shipping the printer, use the original foam packaging to prevent damage.

A "toner bomb" (sever toner spillage) WILL OCCUR if the image drum is not properly packaged for shipping.

Okidata charges a cleaning fee for ALL products sent in for service and received by Okidata with a "toner bomb" condition.

If the shipping instructions are NOT followed, Okidata may levy a surcharge against the dealership.

1. Locate the original foam packaging or order replacement packaging from Okidata. Refer to Appendix B of this Service Handbook.
2. Remove the image drum cartridge.
3. Place the image drum into a black plastic velostat bag. Refer to Appendix B.
4. Store the image drum in a safe place, away from sunlight. Install the drum when the printer is returned.
5. Pack the unit, using the materials from Step 1.

3.6.02 All Other Returns

CAUTION:

The product MUST be returned in the original packaging.

The product MUST be returned with ALL originally supplied factory items.

A "toner bomb" (sever toner spillage) WILL OCCUR if the image drum is not properly packaged for shipping.

Okidata charges a cleaning fee for ALL products sent in for service and received by Okidata with a "toner bomb" condition.

If the shipping instructions are NOT followed, Okidata may levy a surcharge against the dealership.

1. Locate the original foam packaging or order replacement packaging from Okidata. Refer to Appendix B of this Service Handbook.

2. Locate the originally supplied factory items. Refer to Getting Started in the Printer Handbook.
3. Remove the image drum cartridge, with the toner cartridge installed.
4. Place the image drum into a black plastic velostat bag (part of the original packaging). Refer to Appendix B.
5. Install the image drum into the printer.
6. Fold the opening of the black plastic bag twice.
7. Tape the fold closed.
8. Gently closed the LED holder and stacker cover.
9. Pack the unit, using the materials from Step 1.
10. Pack the items listed below.

Software Support Diskette(s)

Printer Handbook

Power Cord

Paper Tray (with cover)

Copyright 1997, Okidata, Division of OKI America, Inc. All rights reserved. See the OKIDATA Business Partner Exchange (BPX) for any updates to this material. (<http://bpx.okidata.com>)

4.1 OVERVIEW

4.1.01 Introduction

This section is used to isolate problems to the assembly level. Application problems and detection of faulty components on the printed circuit boards are NOT addressed.

When troubleshooting a defective unit, follow these steps.

1. Refer to Section 4.3, which explains where to check for updates to the troubleshooting information.
2. Section 4.4 contains tips on preventing problems.
3. Section 4.5 shows samples of abnormal outputs.
4. Section 4.6 provides tables of error messages.
5. Section 4.7 contains the Repair Analysis Procedures (RAPs). Each RAP will ask you questions or require you to make observations. The answers to these questions and the results of your observations determine your next course of action. Use the RAP Index to identify which RAP should be used to resolve the problem with the machine.
6. Section 4.8 provides the procedures for various printer tests.
7. Section 4.2 lists methods for reporting problems. If you encounter a situation that is NOT addressed by the documentation in this kit, please report the problem to Okidata, using one of the methods listed.

Refer to the Service Center Reference Guide for information on contacting Okidata.

Copyright 1997, Okidata, Division of OKI America, Inc. All rights reserved. See the OKIDATA Business Partner Exchange (BPX) for any updates to this material. (<http://bpx.okidata.com>)

4.1.02 Printer Serial Number Identification

To identify the revision level of a printer, record the serial number from the back of the printer.

Refer to the following to decode the serial number.

Example Printer Serial Number: 401A0154693

Date of Manufacture Code 401 (4 = year. 01 = month) January, 1994

Product Revision A

Product Serial Number 0154693

Copyright 1997, Okidata, Division of OKI America, Inc. All rights reserved. See the OKIDATA Business Partner Exchange (BPX) for any updates to this material. (<http://bpx.okidata.com>)

4.1.03 Firmware Revision Identification

To identify the revision level and part number of the firmware, print the menu.

Refer to Section 4.8 or Section 3.3 of this Service Handbook or the Printer Handbook.

Copyright 1997, Okidata, Division of OKI America, Inc. All rights reserved. See the OKIDATA Business Partner Exchange (BPX) for any updates to this material. (<http://bpx.okidata.com>)

4.2 REPORTING PROBLEMS

4.2.01 General Information

Okidata strives to provide accurate and detailed service information through its training materials. The Technical Training Group realizes that service technicians have valuable experience, knowledge, and opinions. Okidata strongly encourages you to report any problems you may encounter when using the materials of this training kit. Please be as specific and detailed as possible. Your comments, suggestions, and criticisms are used to update and revise training kits.

You should reference the training materials when servicing Okidata products. Most problems can be solved by using the information provided in the training materials. If you encounter a situation that cannot be solved, please let Okidata know.

Refer to the Service Center Reference Guide for information on contacting Okidata.

4.2.02 Problem Lists

Technicians frequently request a list of common problems specific to a product. Technical Training Kits are written before a product is shipped to customers. Therefore, such information is NOT available when a product is first released.

However, Okidata wants to respond to these requests. Okilink II provides round-table discussions on technical problems. Errors and corrections in the training materials are listed in the Training Section of Okilink II. The Technical Service Bulletins (also known as Okidatas Monthly Mail) are available via Okilink II. Situations that are NOT addressed in the reference documentation, technical service bulletins, or round-tables may be reported to the Dealer Service and Support Engineers (Contact Technical Support) or the Technical Training Group. You will receive a response to your message within one business day.

The information on Okilink II is the most accurate and up-to-date technical information available from Okidata. This is only possible with your assistance. By reporting your suggestions, concerns, and problems, Okidata can provide the best possible information.

Your cooperation is greatly appreciated. Thank you for your help!

4.2.03 Reporting Methods

Okilink II

You may use Okilink II to report your findings. Refer to the Service Center Reference Guide for information on using Okilink II.

Course Critique

Use the Course Critique to report any problems you find as you are completing the self-paced training.

Fax Number

If you wish to fax your response, please use the numbers listed in the Service Center Reference Guide.

Mailing Address

If you respond by mail, please use the appropriate address listed in the Service Center Reference Guide.

Information Provided

Please provide the following information when reporting problems.

Okidata Dealer Number

Technicians Name

Company Name

Companys Address (Street, City, State/Province, ZIP / Postal Code, Country)

Telephone and Fax Numbers (with area / country access codes)

Product Name

Units Serial Number

Firmware Revision Level

Description of Problem

Document Name (with page number or procedure) with error or problem.

Copyright 1997, Okidata, Division of OKI America, Inc. All rights reserved. See the OKIDATA Business Partner Exchange (BPX) for any updates to this material. (<http://bpx.okidata.com>)

4.3 TROUBLESHOOTING UPDATES

4.3.01 General Information

Okidata distributes updated troubleshooting information in three ways.

Okilink II

Faxable Facts

Technical Service Bulletins

4.3.02 Okilink II

Okilink II is Okidatas Bulletin Board Service. This service is available to all Okidata Certified Service Technicians. Okilink II provides troubleshooting and service information. Technicians can download files, ask questions of Okidatas technical support personnel, and participate in round table discussions about Okidata products and services. Technical Service Bulletins, Recommended Spare Parts Lists, Printer Drivers, Product Specifications, and Service Training Information are also available.

Refer to the Service Center Reference Guide for information on accessing Okilink II.

4.3.03 Faxable Facts

Okidatas Faxable Facts is an automated fax document retrieval system. It is maintained by Okidatas Customer Information Center. Answers to common questions about Okidata products are available through Faxable Facts.

Refer to the Service Center Reference Guide for information on accessing Faxable Facts.

4.3.04 Technical Service Bulletins

Okidatas Technical Service Bulletins (TSBs) contain technical information developed after product release. Firmware updates, part number changes, and procedural changes are some of the subjects covered by these bulletins. The TSBs are distributed through Okilink II.

Refer to the Service Center Reference Guide for information on accessing Okilink II.

4.4 TROUBLESHOOTING TIPS

4.4.01 Preliminary Checks

1. Is the product being operated under the proper ambient conditions?
2. Is the paper being used made specifically for xerographic printing?
3. Has the toner cartridge been replaced as recommended?
4. Has the image drum cartridge been replaced as recommend?
5. Is the toner cartridge properly installed?
6. Is the image drum cartridge properly installed?
7. Is an Okidata toner cartridge being used?
8. Is an Okidata image drum being used?
9. Is the firmware the latest (current) revision?
10. Are the printer drivers being used correct for the printer?
11. Is the printer driver being used the latest (current) release?

4.4.02 Tips for Preventing Image Problems

1. Do not let anything touch the surface of the image drum.
2. NEVER expose the image drum to direct sunlight.
3. Do not touch the fuser unit. Oil from the skin can cause uneven fusing temperature.
4. Do not expose the image drum to light for more than 5 minutes.

4.4.03 Problem Categories

There are three categories of problems that you might encounter when servicing the printer.

1. Unacceptable or missing output.

Refer to Section 4.5 of this Service Handbook. 

Is there a sample resembling the problem?

YES Refer to the specified RAP.

NO Contact Technical Support.

2. Error Message displayed on the operator panel.

Is the Operator Lamp flashing?

YES Refer to Section 4.6 of this Service Handbook.

NO Refer to Section 4.6 of this Service Handbook.

3. Printer does not initialize.

Refer to RAP 01.

Copyright 1997, Okidata, Division of OKI America, Inc. All rights reserved. See the OKIDATA Business Partner Exchange (BPX) for any updates to this material. (<http://bpx.okidata.com>)

4.5 ABNORMAL OUTPUT

4.5.01 Output Samples

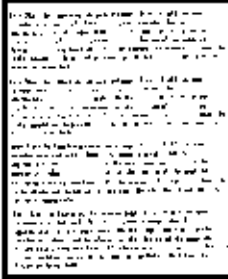

Light Output
Refer to RAP 15



Dark Background
Refer to RAP 16

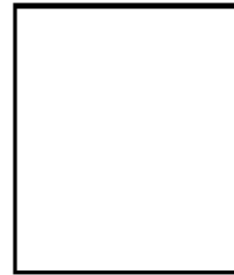

Blank Output
Refer to RAP 17



Black Vertical Stripes / Streaks
Refer to RAP 18

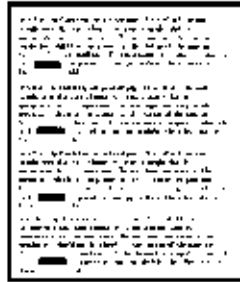

Repetitive Marks
Refer to RAP 19

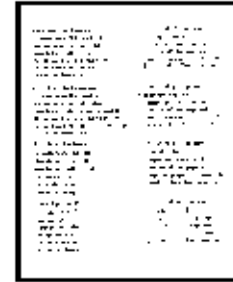

Blank Output (in spots) or
White Vertical Stripes / Streaks
Refer to RAPs 20 and 21



Black Output
Refer to RAP 22

Copyright 1997, Okidata, Division of OKI America, Inc. All rights reserved. See the OKIDATA Business Partner Exchange (BPX) for any updates to this material. (<http://bpx.okidata.com>)

4.6 FAULT ALARMS

4.6.01 Using the Error Message Charts

The LCD Error Message Charts provide the following information.

- LCD Display Message
- Description of the Error Message
- Possible solution to the problem

There are two groups of LCD Error Messages.

- Section 4.6.02

Operator Lamp flashes

- Section 4.6.03

Operator Lamp does not flash

Make sure you refer to the appropriate section when troubleshooting.

4.6.02 Error Messages: Operator Lamp Flashes (Chart A)

Category	LCD Display Message	Description	Solution
Printer Unit (PU) Errors	ERROR PU CONTROL	Overrun of the program on the Printer Unit (PU) side.	Refer to RAP 06.
	ERROR PU EEPROM WRITE	While writing to the EEPROM on the PU an error has occurred.	Refer to RAP 06.
	ERROR PU EEPROM ERROR	The EEPROM on the PU cannot be detected.	1. Make sure the EEPROM is properly installed.
			2. Replace the EEPROM.
	ERROR PU ROM/RAM CHECK	An error has occurred during the PU ROM/RAM check.	Refer to RAP 06.
	ERROR PU FAN MOTOR	The DC Fan has stopped or the +38 vdc is not being supplied to the fan.	Refer to RAP 06.
	ERROR PU FUSER UNIT	The fuser temperature has not reached the prescribed setting.	Refer to RAP 05.
Interface Errors	ERROR CU-PANEL I/F TIMEOUT	A communication error has occurred between the Control Unit (CU) and the Operator Panel.	Refer to RAP 07.
	ERROR CU-PU I/F TIMEOUT	A communication error has occurred between the Control Unit (CU) and the Printer Unit (PU).	Refer to RAP 08.

	ERROR PU-OPTION TIMEOUT	After the PU sends data no response is received from the Option.	1. Replace the engine controller board.
			2. Replace the Option.
	ERROR CU-OPTION I/F TIMEOUT	After the CU sends data no response is received from the Option.	1. Replace the engine controller board.
			2. Replace the Option
	ERROR SERIAL COMMUNICATION	An error has occurred on the serial interface board.	1. Check the serial interface settings in the printer menu.
			2. Replace the serial interface board.
Controller Errors	ERROR OPTION RAM CHECK	A RAM Write/Read compare error occurred on the optional RAM Board.	Refer to RAP 10.
	ERROR CU RAM CHECK	A RAM Write/Read compare error occurred on the RAM of the main controller board.	Refer to RAP 10.
	ERROR CU FONT ROM CHECK	There is a checksum error in the resident font ROM of the main controller board.	Replace the main controller board.
	ERROR CU PROG. ROM CHECK	There is a checksum error in the Program ROM of the main controller board.	Refer to RAP 11.
	ERROR CONTROLLER nnaaaaa Where: nn< >=< >Vector Number aaaaaa = Error Address	An error has occurred on the main controller board.	Replace the main controller board.
EEPROM Error	ERROR EEPROM (The Service Lamp is off)	The printer was powered OFF while writing to the EEPROM. EEPROM data was erased.	Press the RECOVER switch. This will reset the EEPROM to factory (default) settings.

Font Card Errors	ERROR CARD FORMAT CHECK	There is a checksum error on the font card.	Refer to RAP 12.
	ERROR CARD REMOVED ON-LINE	The font card was removed while the printer was ON-LINE.	Power OFF the unit then power ON
	CARD NOT FOUND	The CU could not detect the font card.	Install the card.
Cover Open	COVER OPEN	The upper cover is open.	1. Close the upper cover.
			2. Replace the cover open switch.
			3. Replace the engine controller board.
Jam Errors	PAPER FEED JAM CHECK TRAY n	A jam occurred in the paper tray area. The leading edge of the paper failed to reach the registration sensor within two seconds after hopping.	Refer to RAP 02.
	PAPER INPUT JAM CHECK TRAY n	The leading edge of the paper failed to reach the exit sensor within 9.6 seconds after passing the registration sensor.	Refer to RAP 03.
	PAPER EXIT JAM REMOVE THE PAPER	The exit sensor remained ON longer than expected.	
	ERROR PAPER SIZE CHECK TRAY n	This error occurs when the actual paper length (detected by the registration sensor) differs from the paper length indicated by the tray identification switches.	Refer to RAP 04.
Connection Error	Block Character displayed or missing display	If the block character or missing display occurs for over 30 seconds there is an operator panel malfunction.	Refer to RAP 01.
Paper Out	PAPER OUT TRAY n	The tray has run out of paper.	1. Load paper into the tray.

			2. Check the paper-end sensor for proper operation.
Tray Requests	EXECUTIVE TRAY n CASSETTE REQUEST	Executive Tray is requested.	Replace with the appropriate tray or Press the RESET Switch to force printing with existing tray.
	LETTER TRAY n CASSETTE REQUEST	Letter Tray is requested.	
	A4 TRAY n CASSETTE REQUEST	A4 Tray is requested.	
	A5 TRAY n CASSETTE REQUEST	A5 Tray is requested.	
	LEGAL TRAY n CASSETTE REQUEST	Legal Tray is requested.	
	B5 TRAY n CASSETTE REQUEST	B5 Tray is requested.	
	UNIVER (A6) TRAY 1 CASSETTE REQUEST	A6 Tray is requested.	
	COM-10 TRAY 1 ENVELOPE REQUEST	Com-10 Tray is requested.	
	MONARCH TRAY 1 ENVELOPE REQUEST	Monarch Tray is requested.	
	DL TRAY 1 ENVELOPE REQUEST	DL Tray is requested.	
	C5 TRAY 1 ENVELOPE REQUEST	C5 Tray is requested.	
Buffer Overflow	ERROR RECEIVE BUFFER OVERFLOW	The receive buffer received too much data to be printed on a page.	1. Install more memory.
	ERROR PAGE BUFFER OVERFLOW	The page buffer received too much data to be printed on a page.	2. Reduce the amount of print data.
	ERROR DLL BUFFER OVERFLOW	The DLL buffer received too much data.	3. Reduce the number of DLL's or Macro's cataloged.
	ERROR MACRO BUFFER OVERFLOW	The macro buffer received too much data.	4. Refer to RAP 13.

	ERROR PRINT OVERRUN	Page is too complicated to be printed.	Modify the page make-up (reduce the number of data overlays).
--	------------------------	--	--

Copyright 1997, Okidata, Division of OKI America, Inc. All rights reserved. See the OKIDATA Business Partner Exchange (BPX) for any updates to this material. (<http://bpx.okidata.com>)

4.6.03 Error Messages: Operator Lamp Does Not Flash (Chart B)

Category	LCD Display Message	Description	Solution
Requests for Manual Paper Loading	EXECUTIVE MANUAL PAPER REQUEST	The referenced paper/envelope is requested.	Load the appropriate paper or envelope in the manual tray and press the FORM FEED Switch.
	LETTER MANUAL PAPER REQUEST		
	LEGAL 13" MANUAL PAPER REQUEST		
	LEGAL 14" MANUAL PAPER REQUEST		
	A4 MANUAL PAPER REQUEST		
	A5 MANUAL PAPER REQUEST		
	A6 MANUAL PAPER REQUEST		
	B5 MANUAL PAPER REQUEST		
	MONARCH MANUAL ENVELOPE REQUEST		
	COM-10 MANUAL ENVELOPE REQUEST		
	DL MANUAL ENVELOPE REQUEST		
	C5 MANUAL ENVELOPE REQUEST		
	Reset Operation Error	RESET TO SAVE	A menu setting that affects printing was changed while data is in the print buffer.

			2 Press the RECOVER Switch (for less than 2 seconds). The printer will go OFF-LINE without affecting the current settings.
			3 Press the RESET Switch (for more than 2 seconds). The current setting is changed the unprinted data in the buffer is erased and the printer is placed ON-LINE.
Daily Status	DATA PRESENT .xx	Received data is in the page buffer.	Press the FORM FEED Switch in the OFF-LINE mode to force printing.
	ON-LINE .xx	The printer is in the ON-LINE Mode.	Normal Operation
	OFF-LINE .xx	The printer is in the OFF-LINE Mode.	
	PRINT FONTS	The printer is printing all available fonts.	
	DEMO PAGE PRINT	The demonstration page is being printed.	
	TONER LOW	The toner cartridge is running low.	
	PRINT MENU	The menu is being printed.	
	WARMING UP	The thermal fuser has not yet reached the proper temperature.	
	RESET	The internal status of the printer has been reset.	
	MENU RESET	The printer menu will default to factory settings.	
	CHANGE DRUM	The image drum cartridge needs to be replaced	Replace the image drum cartridge then power ON the power while pressing the RESET Switch.

	FUSER LIFE	End of thermal fuser life reached (180,000 pages).	Replace the fuser unit then reset the fuser counter (refer to Section 3 of this Service Handbook).
--	------------	--	--

Copyright 1997, Okidata, Division of OKI America, Inc. All rights reserved. See the OKIDATA Business Partner Exchange (BPX) for any updates to this material. (<http://bpx.okidata.com>)

4.7 REPAIR ANALYSIS PROCEDURES (RAPs)

4.7.01 Using the RAPs

When using the Repair Analysis Procedures, follow these steps.

1. Go to the RAP Index.
2. Find the RAP which is associated with the printers problem.
3. Go to the appropriate RAP.
4. All RAPs begin with a START statement, followed by questions or another type of statement.

Copyright 1997, Okidata, Division of OKI America, Inc. All rights reserved. See the OKIDATA Business Partner Exchange (BPX) for any updates to this material. (<http://bpx.okidata.com>)

4.7.02 RAP Index

RAP Number	Problem Description
1	Printer Does Not Initialize
2	Paper Feed Jam
3	Paper Jam
4	Paper Size Error
5	Fusing Problem
6	PU Error
7	Operator Panel Communication Error
8	Communication Error Between PU and CU
9	Loop Test Failure (RS232-C)
10	Resident/Optional RAM Failure
11	Program ROM Failure
12	Optional Font Card Failure
13	Receive Buffer Overflow
14	No Display on Operator Panel
15	Images are Light or Blurred
16	Dark Background Density
17	Blank Paper Is Output
18	Black Vertical Stripes
19	Repetitive Spaced Marks on Output
20	Random Missing Output
21	White Vertical Stripes
22	Black Page Is Output
23	Printing Incorrect Characters

Copyright 1997, Okidata, Division of OKI America, Inc. All rights reserved. See the OKIDATA Business Partner Exchange (BPX) for any updates to this material. (<http://bpx.okidata.com>)

RAP 01: Printer Does Not Initialize

START

Check the F1 (8 amp AC line fuse). Replace if necessary.

Power OFF the unit, then power ON. Do the operator panel lamps light?

YES Go to A

NO Go to B

A

Do the fan and motor power ON?

YES Does the fuser lamp power ON?

NO Refer to RAP 05.

YES The following are the most likely defective assemblies. Replace in the order listed, checking for proper operation before going to the next item listed.

1. Main control board PROM.

2. Engine controller board.

Is the problem resolved?

YES End of procedure.

NO Contact Technical Support.

NO Remove the main control board.

Do the fan and main motor turn on?

YES Replace the main controller board.

NO Measure the voltage between pin 14 and pin 15 of connector J6 on the engine controller board.

Does it measure approximately +38 vdc?

YES The following are the most likely defective assemblies. Replace in the order listed, checking for proper operation before going to the next item listed.

1 - Cover Open Switch

2 - Engine Controller Board

3 - Power Supply Unit

NO Go to C

B

Measure the voltage between pin 1 and pin 3 of connector (PU) on the main controller board.

Does it measure +4.75vdc to +5.25vdc?

YES The following are the most likely defective assemblies. Replace in the order listed, checking for proper operation before going to the next item listed.

1 - Operator Panel

2 - Engine Connection Board

3 - Main Controller Board

NO Remove the main controller board.

Measure the voltage between pin 32 and pin 34 of connector J6 on the engine controller board.

Does it measure +4.75vdc to +5.25vdc?

YES Replace the main controller board.

NO Remove the engine controller board.

Measure the voltage between pin 32 and pin 34 of connector CN1 on the power supply unit.

Does it measure +4.75vdc to +5.25vdc?

NO Replace the power supply unit.

YES Replace the possible defective assemblies in the order listed.

1 - Engine Controller Board

2 - Engine Connection Board

3 - Operator Panel

C

Remove the AC power from the printer.

Check F2 (2 amp, +38vdc circuit fuse) on the power supply unit.

Is the fuse open?

NO Replace the power supply unit.

YES Replace the fuse (soldered).

Install the engine controller board.

Measure the resistance between pin 14 and pin 15 of connector J6 on the engine controller board.

Is the resistance 0 ohms?

YES Replace the possible defective assemblies in the order listed.

1 - Engine Controller Board

2 - Main Motor

3 - Fan

4 - Registration Motor

NO Install remaining assemblies. Test printer.

Copyright 1997, Okidata, Division of OKI America, Inc. All rights reserved. See the OKIDATA Business Partner Exchange (BPX) for any updates to this material. (<http://bpx.okidata.com>)

RAP 02: Paper Feed Jam

START

When does the paper jam alarm occurs?

As soon as the unit is powered ON. Go to A.

After the printer attempts to print. Go to B.

A

Is paper jammed at the registration sensor?

YES Remove the paper.

NO Raise the stacker cover

Lift the upper unit

Block the registration sensor with a piece of paper

Override the cover open switch.

Is the jam error cleared?

YES Remove the paper

Replace all printer covers

Check the registration sensor lever for normal operation.

NO Replace the engine controller board.

B

Is the paper moving?

YES Go to C.

NO Go to D.

C

Is the paper reaching the registration sensor lever?

YES Raise the stacker cover.

Lift the upper unit

Block the registration sensor with a piece of paper

Override the cover open switch.

Is the jam error cleared?

YES Remove the paper.

Replace all printer covers.

Check the registration sensor lever for normal operation.

NO Replace the engine controller board.

NO Are there obstructions in the paper path?

NO Replace the possible defective assemblies in the order listed.

1 - Registration Motor

2 - Paper Supply Unit

3 - Engine Controller Board

YES Remove the obstructions.

Is the problem resolved?

YES End of procedure

NO Contact Technical Support

D

Measure the voltage at Connector J5 between pins 12, 13, 14, 15, 16 (registration Motor Drive) and pin 6 (Ground).

Which voltage was measured?

0 vdc

Replace the engine controller board.

Is the problem resolved?

YES End of procedure

NO Contact Technical Support

+38vdc

Does the registration motor turn when attempting to feed paper?

NO Replace the possible defective assemblies in the order listed.

1 - Registration Motor

2 - Paper Supply Unit

3 - Engine Controller Board

YES Replace the possible defective assemblies in the order listed.

1 - Paper Supply Unit

2 - Registration Motor

Copyright 1997, Okidata, Division of OKI America, Inc. All rights reserved. See the OKIDATA Business Partner Exchange (BPX) for any updates to this material. (<http://bpx.okidata.com>)

RAP 03: Paper Jam

START

When does the paper jam alarm occurs?

As soon the unit is powered ON. Go to A.

After the printer attempts to print. Go to B.

A

Is paper at the registration or exit sensor?

YES Remove the paper.

NO Remove the upper cover.

Detach the main controller board.

Measure the voltage at IC3 pin 37 of the engine controller board as you lift and lower the paper exit sensor lever.

Does the voltage reading change between 0 vdc and +5 vdc as you move the lever?

NO Replace the engine controller board.

YES Replace the possible defective assemblies in the order listed.

1 - Engine Controller Board

2 - Paper Exit Sensor Lever

3 - Main Controller Board

B

Does the paper move beyond the registration sensor?

NO Replace the possible defective assemblies in the order listed.

1 - Engine Controller Board

2 - Main Motor

Is the problem resolved?

YES End of procedure

NO Contact Technical Support

YES Is the paper reaching the paper exit sensor lever?

YES Raise the stacker cover.

Lift the upper unit.

Block the registration sensor with a piece of paper.

Override the cover open switch.

Is the jam error cleared?

YES Remove the paper

Replace all printer covers.

Check the paper exit sensor lever for normal operation.

NO Replace the engine controller board.

NO Are there obstructions in the paper path?

NO Replace the possible defective assemblies in the order listed.

1 - Registration Motor

2 - Paper Supply Unit

3 - Engine Controller Board

YES Remove the obstructions.

Is the problem resolved?

YES End of procedure

NO Contact Technical Support

RAP 04: Paper Size Error

START

Use the paper length specified on the paper tray.

Raise the stacker cover

Lift the upper unit.

Check the registration sensor lever for normal operation.

Does the registration sensor lever move freely?

NO Replace the registration lever sensor.

YES Does the paper exit sensor lever move freely?

NO Replace the registration lever sensor.

YES Are there obstructions in the paper path?

NO Possible defective assemblies:

1 - Tray detection switches on engine connection board

2 - Engine Controller Board

3 - Paper Supply Unit

4 - Main Controller Board

YES Remove the obstructions.

Is the problem resolved?

YES End of procedure

NO Contact Technical Support

RAP 05: Fusing Problem

START

Look through the right side vent of the printer. Does the fuser lamp light?

YES

Measure the resistance between pins 1 and 2 of the cable connected to J2 on the engine controller board.

Is the resistance approximately 100K Ohm?

NO Replace the possible defective assemblies in the order listed.

1 - Fuser Assembly (the thermistor is defective)

2 - Engine Controller Board

YES Replace the possible defective assemblies in the order listed.

1 - Engine Controller Board

2 - Main Controller Board

3 - Fuser Assembly

NO

Open the upper cover.

Lift the upper unit. Verify that the fusers AC connections are NOT recessed into the holder.

Measure the resistance between the fusers AC connections.

Is the resistance approximately zero ohms?

NO Replace the fuser assembly.

Is the problem resolved?

YES End of procedure

NO Contact Technical Support

YES Check the voltage at J6 pin 37 on the engine controller board.

Is the measurement approximately +5 vdc?

NO Replace the engine controller board.

Is the problem resolved?

YES End of procedure

NO Contact Technical Support

YES Is the power supply placed under the rear claws of the printer base?

NO Install the power supply properly.

Is the problem resolved?

YES End of procedure

NO Contact Technical Support

YES Replace the power supply unit.

Is the problem resolved?

YES End of procedure

NO Contact Technical Support

Copyright 1997, Okidata, Division of OKI America, Inc. All rights reserved. See the OKIDATA Business Partner Exchange (BPX) for any updates to this material. (<http://bpx.okidata.com>)

RAP 06: PU Error

START

Replace the engine controller board.

Has the problem been resolved?

YES End of procedure

NO Replace the main controller board.

Has the problem been resolved?

YES End of procedure.

NO Contact Technical Support

RAP 07: Operator Panel Communication Error

START

Check the ribbon cable connections at the operator panel and J5 of the engine controller board.

Is it properly connected?

YES Go to A

NO Connect it properly.

Is the problem resolved?

YES End of procedure

NO Go to A

A

Replace the operator panel assembly.

Is the problem resolved?

YES End of procedure

NO Replace the main controller board.

Is the problem resolved?

YES End of procedure

NO Replace the possible defective assemblies in the order listed.

1 - Engine Connection Board

2 - Engine Controller Board

RAP 08: Communication Error Between PU and CU

START

Check that connector (PU) on the main controller board is making good contact with J7 of the engine controller board.

Are CN7 and J7 properly connected?

NO Connect them properly.

YES Replace the main controller board.

Is the problem resolved?

YES End of procedure

NO Replace the engine controller board.

Is the problem resolved?

YES End of procedure

NO Contact Technical Support

RAP 09: Loop Test Failure (RS-232C)

START

Is the loop test connector installed?

NO Install the loop test connector.

Refer to Section 4.8 for a wiring diagram.

Perform the Serial Loop Test.

YES Replace the serial interface board (option).

Is the problem resolved?

YES End of procedure

NO Replace the main controller board.

Is the problem resolved?

YES End of procedure

NO Contact Technical Support

RAP 10: Resident/Optional RAM Failure

START

Remove the optional RAM board(s).

Is the problem resolved?

NO Replace the main controller board.

Is the problem resolved?

YES End of procedure

NO Contact Technical Support

YES Reinstall the optional RAM board(s).

Is the problem resolved?

YES End of procedure

NO Replace the optional RAM board.

Is the problem resolved?

YES End of procedure

NO Contact Technical Support

RAP 11: Program ROM Failure

START

Replace the Program ROM on the main controller board.

Is the problem resolved?

YES End of Procedure.

NO Remove the main controller board.

Perform Engine Test - B. Refer to Section 4.8 of this Service Handbook.

Does the test run properly?

YES Go to A.

NO Replace the engine controller board.

Does the engine test run properly?

NO Contact Technical Support

YES Go to A.

A

Reinstall the main controller board.

Perform the Continuous Print Test. Refer to Section 4.8 of this Service Handbook.

Is the problem resolved?

YES End of Procedure.

NO Replace the main controller board.

Is the problem resolved?

YES End of procedure.

NO Contact Technical Support

Copyright 1997, Okidata, Division of OKI America, Inc. All rights reserved. See the OKIDATA Business Partner Exchange (BPX) for any updates to this material. (<http://bpx.okidata.com>)

RAP 12: Optional Font Card Failure

START

Replace the font card.

Is the problem resolved?

YES End of procedure

NO Make sure the font card board is firmly attached to the main controller board.

Is the problem resolved?

YES End of procedure

NO Replace the main controller board.

Is the problem resolved?

YES End of procedure

NO Contact Technical Support

RAP 13: Receive Buffer Overflow

START

Determine the method of flow control being used by the Host and the printer (X-ON/X-OFF or READY BUSY).

Is the same method being used at the Host and on the printer?

NO Set the flow control via the Level 2 MENU.

Is the problem resolved?

YES End of procedure

NO Go to the next step listed below.

YES Replace the possible defective assemblies in the order listed.

1 - Interface Cable configuration is incorrect

2 - Interface Cable

3 - Serial Interface Board

4 - Main Controller Board

Is the problem resolved?

YES End of procedure

NO Contact Technical Support

RAP 14: No Display on Operator Panel

START

Check the cable connections at the operator panel and J5 of the engine controller board.

Is the problem resolved?

YES End of procedure

NO Measure the voltage between pin 1 and pin 3 at connector CN7 on the main controller board.
Is the voltage between +4.75vdc and +5.25vdc?

YES Go to RAP 07.

NO Remove the main controller board.

Measure the voltage between pin 13 and pin 14 at J6 on the engine controller board.

Is the voltage between +4.75vdc and +5.25vdc?

YES Replace the main controller board.

Is the problem resolved?

YES End of procedure

NO Contact Technical Support

NO Remove the cable from J5 on the engine controller board.

Measure the voltage between pins 13 pin 14 at J6 on the engine controller board.

Is the voltage between +4.75vdc and +5.25vdc?

NO Replace the power supply unit.

Is the problem resolved?

YES End of procedure

NO Contact Technical Support

YES Replace the possible defective assemblies in the order listed.

1 - Engine Connection Board

2 - Operator Panel Assembly

3 - Engine Controller Board

Copyright 1997, Okidata, Division of OKI America, Inc. All rights reserved. See the OKIDATA Business Partner Exchange (BPX) for any updates to this material. (<http://bpx.okidata.com>)

RAP 15: Images are Light or Blurred

START

Does the printer contain sufficient toner?

NO Add toner.

YES Is the paper recommended for use in a laser printer?

NO Use paper recommended for a laser printer.

YES Print the menu.

Raise the stacker cover to stop the print cycle just as the bottom of the paper goes under the hopping roller.

Lift the upper unit, remove the paper and look at the image drum.

Is there a dark toner image on the drum?

YES Replace the possible defective assemblies in the order listed.

1 - Transfer Charger Assembly

2 - High Voltage Power Supply

3 - Engine Controller Board

NO Clean the LED head.

Is the problem resolved?

YES End of procedure

NO Replace the possible defective assemblies in the order listed.

1 - Image Drum Cartridge

2 - Engine Controller Board

3 - High Voltage Power Supply

Is the problem resolved?

YES End of procedure

NO Contact Technical Support

Copyright 1997, Okidata, Division of OKI America, Inc. All rights reserved. See the OKIDATA Business Partner Exchange (BPX) for any updates to this material. (<http://bpx.okidata.com>)

RAP 16: Dark Background Density

START

Clean the charge wire.

Is the problem resolved?

YES End of procedure

NO Has the image drum been exposed to external light?

YES Test the printer after 30 minutes.

This will allow the drum surface enough time to recover its photoconductive properties.

Is the problem resolved?

NO Go to A.

YES End of procedure

NO Go to A.

A

Replace the fuser cleaner pad.

Is the problem resolved?

YES End of procedure

NO Possible defective assemblies. Replace in the order listed.

1 - Image Drum Cartridge

2 - High Voltage Power Supply Unit

3 - Engine Controller Board

Is the problem resolved?

YES End of procedure

NO Contact Technical Support

Copyright 1997, Okidata, Division of OKI America, Inc. All rights reserved. See the OKIDATA Business Partner Exchange (BPX) for any updates to this material. (<http://bpx.okidata.com>)

RAP 17: Blank Paper is Output

START

Inspect the transfer wire.

Is the transfer wire broken?

YES Replace the transfer wire.

Is the problem resolved?

YES End of procedure

NO Go to the next step listed below.

NO Replace the high voltage power supply unit.

Is the problem resolved?

YES End of procedure

NO Clean the ground contact of the image drum cartridge.

Is the problem resolved?

YES End of procedure

NO Replace the image drum cartridge.

Is the problem resolved?

YES End of procedure

NO Remove the main controller board.

Perform Engine Test - B. Refer to Section 4.8 of this Service Handbook.

Does the test run properly?

YES Go to A

NO Replace the engine controller board.

Does the engine test run properly?

NO Contact Technical Support

YES Go to A

A

Reinstall the main controller board.

Perform the Continuous Print Test. Refer to Section 4.8 of this Service Handbook

Is the problem resolved?

YES End of procedure

NO Replace the main controller board.

Is the problem resolved?

YES End of procedure

NO Replace the LED head.

Is the problem resolved?

YES End of procedure

NO Contact Technical Support

Copyright 1997, Okidata, Division of OKI America, Inc. All rights reserved. See the OKIDATA Business Partner Exchange (BPX) for any updates to this material. (<http://bpx.okidata.com>)

RAP 18: Black Vertical Stripes

START

Is the charge wire cleaning tab in the storage position?

NO Move the tab to the right side of the image drum cartridge.

Is the problem resolved?

YES End of procedure

NO Go to the next step listed below.

YES Clean the charge wire.

Is the problem resolved?

YES End of procedure

NO Possible defective assemblies are listed below. Replace in the order listed.

1 - Image Drum Cartridge. Reset the drum counter

2 - Engine Controller Board

3 - LED Head

Is the problem resolved?

YES End of procedure

NO Contact Technical Support.

RAP 19: Evenly Spaced Marks on Output**START**

Measure the distance between the marks. Find the distance below and perform the suggested correction.

· 2.0 inches

Clean / replace the registration rollers.

· 2.27 inches

Check / replace the image drum cartridge.

· 2.47 inches

Clean / replace the fuser cleaner pad / fuser assembly.

· 2.72 inches

Clean / replace the pressure roller.

· 3.7 inches

Check / replace the image drum cartridge.

· 4.75 inches

Check / replace the hopping roller.

RAP 20: Random Missing Output

START

Does the printer contain sufficient toner?

NO Add toner.

YES Is the paper recommended for use in a laser printer?

NO Use paper recommended for a laser printer.

YES Perform the Continuous Print Test.

Raise the stacker cover to stop the print cycle just as the bottom of the paper goes under the hopping roller.

Lift the upper unit, remove the paper and look at the image drum.

Is there a complete toner image on the drum?

YES Possible defective assemblies are listed below. Replace in the order shown.

1 - Fuser Cleaner Pad

2 - Clean the Fuser Roller (A dirty roller can cause uneven temperature.)

3 - Transfer Charger Assembly

4 - Engine Controller Board

5 - High Voltage Power Supply

6 - Fuser Assembly

NO Clean the LED head.

Is the problem resolved?

YES End of procedure

NO Possible defective assemblies (replace in the order shown)

1 - Image Drum Cartridge

2 - Engine Controller Board

3 - High Voltage Power Supply

4 - Main Controller Board

Is the problem resolved?

YES End of procedure

NO Contact Technical Support

Copyright 1997, Okidata, Division of OKI America, Inc. All rights reserved. See the OKIDATA Business Partner Exchange (BPX) for any updates to this material. (<http://bpx.okidata.com>)

RAP 21: White Vertical Stripes

START

Does the printer contain sufficient toner?

NO Add toner.

YES Is the paper recommended for use in a laser printer?

NO Use paper recommended for a laser printer.

YES Perform the Continuous Print Test.

Raise the stacker cover to stop the print cycle just as the bottom of the paper goes under the hopping roller.

Lift the upper unit, remove the paper and look at the image drum.

Is there a complete toner image on the drum?

YES Possible defective assemblies are listed below. Replace in the order shown.

1 - Fuser Cleaner Pad

2 - Fuser Roller (Uneven temperature can be caused by a dirty roller)

3 - Transfer Charger Assembly

4 - Engine Controller Board

5 - High Voltage Power Supply

6 - Fuser Assembly

NO Clean the LED head.

Is the problem resolved?

YES End of procedure

NO Possible defective assemblies (replace in the order shown)

1 - Image Drum Cartridge

2 - Engine Controller Board

3 - High Voltage Power Supply

4 - Main Controller Board

Is the problem resolved?

YES End of procedure

NO Contact Technical Support

Copyright 1997, Okidata, Division of OKI America, Inc. All rights reserved. See the OKIDATA Business Partner Exchange (BPX) for any updates to this material. (<http://bpx.okidata.com>)

RAP 22: Black Page is Output

START

Examine the charge wire (you can see it through the top of the image drum cartridge).

Is the charge wire broken?

YES Replace the image drum cartridge. Reset the drum counter. Refer to Section 3.3 of this Service Handbook.

NO Replace the high voltage power supply.

Is the problem resolved?

YES End of procedure

NO Replace the LED Head.

Is the problem resolved?

YES End of procedure

NO Replace the engine controller board.

Is the problem resolved?

YES End of procedure

NO Replace the image drum cartridge. Reset the drum counter. Refer to Section 3.3 of this Service Handbook.

Is the problem resolved?

YES End of procedure

NO Contact Technical Support

RAP 23: Printing Incorrect Characters

NOTE:

This RAP addresses problems occurring under the conditions listed below.

1. Parallel printing directly from DOS routines.
2. OL810 printers with serial numbers below 205A0003274. Refer to Section 4.1 of this Service Handbook for information on serial number identification.

START

Verify proper interface cabling and proper operation of the computer interface board.

Is the problem resolved?

YES End of procedure.

NO Replace the main control board.

Is the problem resolved?

YES End of procedure.

NO Contact Technical Support.

4.8 PRINTER TESTS

General Information

This section covers the seven printer tests listed below.

1. Continuous Print (Rolling ASCII)
2. Font Sample
3. Hexadecimal Dump Mode
4. Serial Interface Diagnostic
5. Engine Test A
6. Engine Test B
7. Menu Print
8. Demo Page Print

The Rolling ASCII and Font Tests check print operations.

The Hexadecimal Dump Mode checks the data transfer between the computer and printer.

The Serial Interface Loopback Test checks the operation of the serial interface board.

Engine Test A tests the print engine mechanism independently from the main controller board.

Engine Test B accesses the engine firmware revision level, the modified page count, the fuser count, the drum count, and the actual page count independently from the main controller board.

Menu Print provides a printed record of the program ROM revision level, the font ROM revision level, the amount of printer page memory, factory menu settings, and user selected menu settings.

Demo Page print provides a sample of the capabilities of the printer.

4.8.01 Continuous Print (Rolling ASCII) Test

General Information

The rolling ASCII test prints a continuous printout of all 96 ASCII characters. The characters are shifted one position to the right on subsequent lines.

Use this test to check the following items.

1. Print Quality

Across the entire length of a line

Down the entire page

2. Line Spacing

3. Character Formation

To perform the Rolling ASCII Test, follow these steps.

1. Press and hold the RECOVER/Reset switch as you power ON the printer.
2. After approximately 10 seconds, the operator panel will display SYS. MAINTENANCE.
3. Press the MENU1/*Menu2* switch repeatedly until the message CONTINUOUS PRINT is displayed on the operator panel.
4. Press the ENTER/*Quiet* switch to start the test.
5. Press the ON-LINE switch to stop the test. The message CONTINUOUS PRINT BROKED will be displayed on the operator panel.
6. To return the printer to normal operation, power OFF the printer, then power ON.

Sample

4.8.02 Font Sample Test

General Information

The Font Sample Test prints samples of the various fonts that can be accessed in the current emulation.

To perform the Font Sample Test, follow these steps.

1. Power ON the printer and wait for the printer to go ON-LINE.
2. Press the ON-LINE switch to take the printer OFF-LINE.
3. Press the PRINT FONTS/Print Menu switch for 1 second.
4. The DATA lamp will light, the READY lamp will flash, and the message PRINT FONTS will be displayed on the operator panel.
5. Samples of the available fonts will be printed.
6. When printing is completed, the printer will be OFF-LINE. Press the ON-LINE switch to place the printer ON-LINE.

NOTE:

The test prints the available fonts based on the selected printer emulation.

Sample

OL810 LED PAGE PRINTER

HP LaserJet III Emulation

Font No.	Font ID	Font Name	(Style) (Weight)	Pitch (CPI)	Point Size	Num. of Symbol	Print Sample
HP LJ III Resident Bitmapped Fonts							
1000		Courier		10.00	12.0	40	ABCDEFghijkl01234 #S%&@ [\]^_`{ }~
1001		Courier	Bold	10.00	12.0	40	ABCDEFghijkl01234 #S%&@ [\]^_`{ }~
1002		Courier	Italic	10.00	12.0	40	ABCDEFghijkl01234 #S%&@ [\]^_`{ }~
1003		Courier		12.00	10.0	40	ABCDEFghijkl01234 #S%&@ [\]^_`{ }~ ÅÊÏÓ à
1004		Courier	Bold	12.00	10.0	40	ABCDEFghijkl01234 #S%&@ [\]^_`{ }~ ÅÊÏÓ à
1005		Courier	Italic	12.00	10.0	40	ABCDEFghijkl01234 #S%&@ [\]^_`{ }~ ÅÊÏÓ à
1006		LN Printer		16.66	8.5	40	ABCDEFghijkl01234 #S%&@ [\]^_`{ }~ ÅÊÏÓ àÊÏÓ ÆËË ÆËË ÆËË ÆËË

HP B/F Cartridge Compatible Resident Bitmapped Fonts

1007	Swiss	Bold	prop(B)	14.4	1	1	ABCDEFghijkl01234 #S%&@ [\]^_`{ }~
1008	Swiss	Bold	prop(F)	14.4	40	1	ABCDEFghijkl01234 #S%&@ [\]^_`{ }~
1009	Dutch		prop(B)	10.0	1	1	ABCDEFghijkl01234 #S%&@ [\]^_`{ }~
1010	Dutch	Bold	prop(B)	10.0	1	1	ABCDEFghijkl01234 #S%&@ [\]^_`{ }~
1011	Dutch	Italic	prop(B)	10.0	1	1	ABCDEFghijkl01234 #S%&@ [\]^_`{ }~
1012	Dutch		comp(B)	10.0	1	1	ABCDEFghijkl01234 #S%&@ [\]^_`{ }~
1013	Dutch	Bold	comp(B)	10.0	1	1	ABCDEFghijkl01234 #S%&@ [\]^_`{ }~
1014	Dutch	Italic	comp(B)	10.0	1	1	ABCDEFghijkl01234 #S%&@ [\]^_`{ }~
1015	Dutch		prop(F)	10.0	40	1	ABCDEFghijkl01234 #S%&@ [\]^_`{ }~ ÅÊÏÓ à
1016	Dutch	Bold	prop(F)	10.0	40	1	ABCDEFghijkl01234 #S%&@ [\]^_`{ }~ ÅÊÏÓ à
1017	Dutch	Italic	prop(F)	10.0	40	1	ABCDEFghijkl01234 #S%&@ [\]^_`{ }~ ÅÊÏÓ à
1018	Dutch		prop(B)	8.0	1	1	ABCDEFghijkl01234 #S%&@ [\]^_`{ }~
1019	Dutch		comp(B)	8.0	1	1	ABCDEFghijkl01234 #S%&@ [\]^_`{ }~
1020	Dutch		prop(F)	8.0	40	1	ABCDEFghijkl01234 #S%&@ [\]^_`{ }~ ÅÊÏÓ àÊÏÓ ÆËË ÆËË ÆËË ÆËË

HP LJ III Resident Scalable Fonts

1025	CG Times		prop scale		50	1	ABCDEFghijkl01234 #S%&@ [\]^_`{ }~ ÅÊÏÓ à
1026	CG Times	Bold	prop scale		50	1	ABCDEFghijkl01234 #S%&@ [\]^_`{ }~ ÅÊÏÓ à
1027	CG Times	Italic	prop scale		50	1	ABCDEFghijkl01234 #S%&@ [\]^_`{ }~ ÅÊÏÓ à
1028	CG Times	Italic Bold	prop scale		50	1	ABCDEFghijkl01234 #S%&@ [\]^_`{ }~ ÅÊÏÓ à
1029	Univers		prop scale		50	1	ABCDEFghijkl01234 #S%&@ [\]^_`{ }~ ÅÊÏÓ à
1030	Univers	Bold	prop scale		50	1	ABCDEFghijkl01234 #S%&@ [\]^_`{ }~ ÅÊÏÓ à
1031	Univers	Italic	prop scale		50	1	ABCDEFghijkl01234 #S%&@ [\]^_`{ }~ ÅÊÏÓ à
1032	Univers	Italic Bold	prop scale		50	1	ABCDEFghijkl01234 #S%&@ [\]^_`{ }~ ÅÊÏÓ à

4.8.03 Hexadecimal Dump Mode

General Information

The hexadecimal dump mode allows you to view the data sent from a computer to the printer. When the printer is in hexadecimal dump mode, all data received (both printable characters and control codes) will be printed in both hexadecimal and ASCII format.

NOTE:

In the ASCII format, all non-printable characters will be represented by a period.

Example

Below is a line of BASIC code.

```
LPRINT CHR$(27);"0";CHR$(30);"This is an example of hexadecimal dump."
```

Below is the same line as it would appear in Hexadecimal Dump Mode.

```
1B 30 1E 54 68 69 73 20 69 73 20 61 6E 20 65 78 .0. This is an ex  
61 6D 70 6C 65 20 66 20 61 20 68 65 78 61 64 ample of a hexad  
65 63 69 6D 61 6C 20 64 75 6D 70 2E 0D 0A ecimal dump
```

Procedure

Follow these steps to engage the Hexadecimal Dump Mode.

1. Make sure the printer is connected to a computer.
2. Verify that paper is loaded.
3. Verify that the image drum and toner cartridge are correctly installed.
4. Power OFF the printer.
5. Press and hold MENU 1 / Menu 2 while powering on the printer.
6. Hold the switches until the operator panel displays the line shown below.

MAINTENANCE MODE

7. Press MENU 1 / Menu 2 twice.

8. Press ENTER / QUIET.
 9. The printer is ready to receive data in the Hexadecimal Dump Mode.
 10. Send data to the printer from the computer.
 11. To exit Hexadecimal Dump Mode, power OFF the printer.
-

Copyright 1997, Okidata, Division of OKI America, Inc. All rights reserved. See the OKIDATA Business Partner Exchange (BPX) for any updates to this material. (<http://bpx.okidata.com>)

4.8.04 Serial Interface Loopback Test

NOTE:

In order to run this test, the serial interface board must be installed with a serial loopback test connector attached to it.

The Serial Interface Diagnostic is used to verify the proper operation of the serial port and its associated circuitry.

To perform the Serial Interface Diagnostic, follow these steps.

1. Place a DB-25P Loopback Test Connector on the serial port (refer to the diagram).
2. Select the serial interface in MENU 1.
3. Press and hold the RECOVER/*Reset* switch as you power ON the printer.
4. After approximately 10 seconds, the operator panel will display SYS. MAINTENANCE.
5. Press the MENU1/*Menu2* switch repeatedly until the message LOOP TEST is displayed on the operator panel.
6. Press the ENTER/*Quiet* switch to start the test.
7. To return the printer to normal operation, power OFF the printer, then power ON.

NOTE:

The number of times the test passes will be displayed in the lower right corner of the operator panel display. If this diagnostic fails, LOOP TEST FAILURE will be displayed. Refer to RAP 09 if the test fails.

Loopback Connector Configuration

1. Jumper the following pins together.

Pin 2 to Pin 3

Pin 4 to Pin 5

Pin 8 to Pin 11

Pin 6 to Pin 20

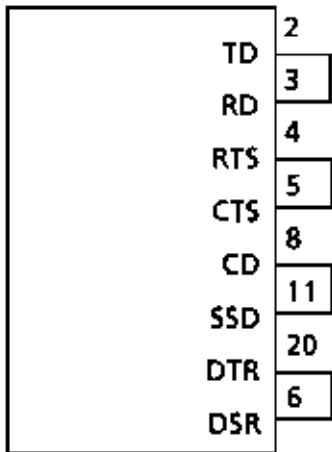

Serial Cable Information

The information in this section will help you make a serial cable to connect between the printer and computer.

Refer to the computer documentation to determine the cable requirements on the computers end.

The printer has a 25 pin, DB-25S receptacle.

The printer has the following cable requirements.

- Shielded, RS-232C cable (Beldon or equivalent), twisted pair conductors.
- UL and CSA approved
- No more than 50 feet long
- Cannon DB-25P plug (or equivalent) with 25 pins
- Cannon DB-C2-J9 (or equivalent) connector shell

Serial Interface Signal Requirements

Pin	Signal	Symbol	Direction	Description
1	Protective Ground	PG	Ground	Connected to the printer frame
2	Transmit Data	TD	From Printer	Serial data transmitted to the system
3	Receive Data	RD	To Printer	Serial data received by the printer
4	Request to Send	RTS	From Printer	Always set to low (mark)
5	Not Used			
6	Data Set Ready	DSR	To Printer	Indicates that data can be sent

7	Signal Ground	SG	Ground	Ground
8 to 10	Not Used			
11	Supervisory Send Data	SSD	From Printer	Indicates that the printer is not ready to receive data
12 to 19	Not Used			
20	Data Terminal Ready	DTR	From Printer	Indicates that the printer is not ready to receive data
21 to 25	Not Used			

Commonly Used Serial Cable Configurations

IBM 25-Pin Cable Configuration

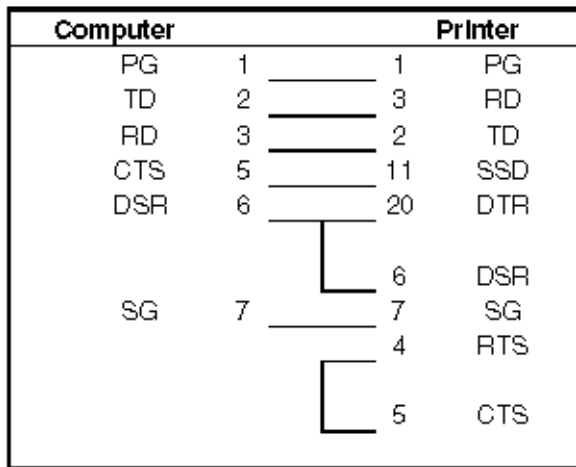

IBM 9-Pin Cable Configuration

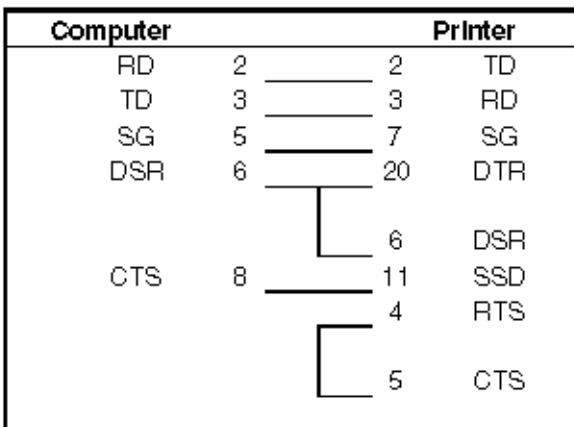

4.8.05 Engine Test A

The Engine Test A provides the technician with a method for testing the print engine mechanism independent of the main controller board.

To perform Engine Test A, follow these steps.

1. Remove the upper cover.
2. Override the cover interlock switch and power ON the printer.
3. Allow approximately one minute for the printer to initialize, then press switch SW1 on the engine controller board for one second.
4. The printer will start printing repetitive horizontal lines.
5. To stop printing, press switch SW1 on the engine controller board.

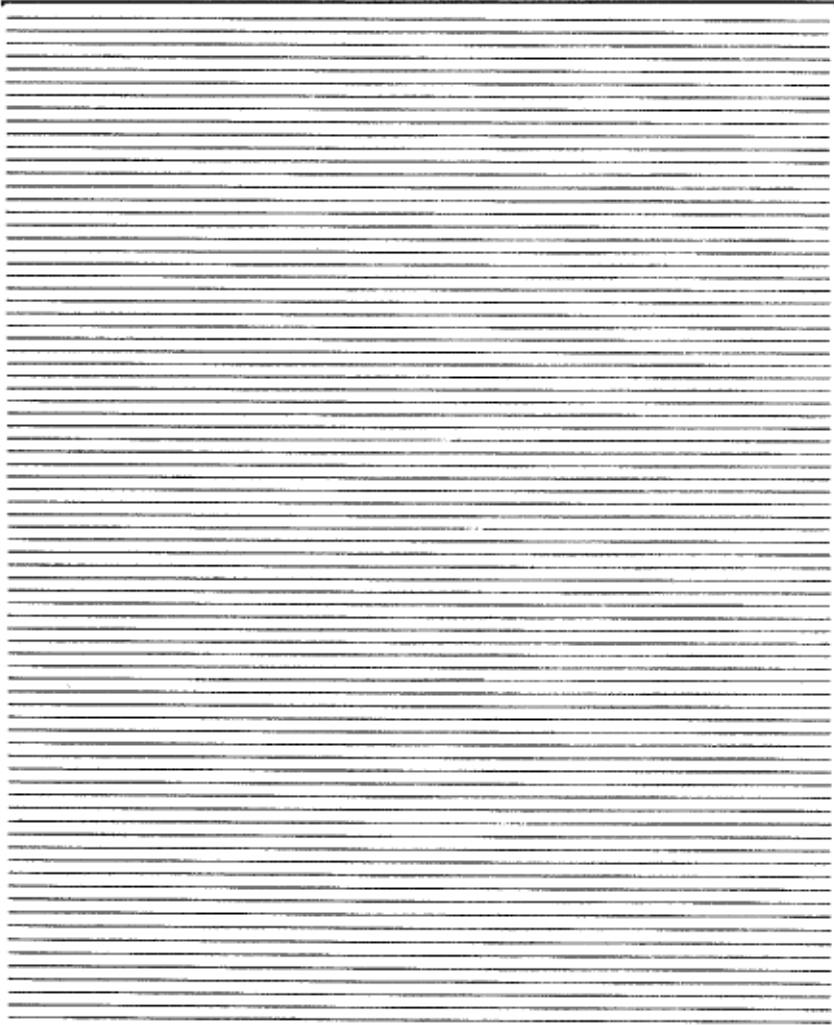

Copyright 1997, Okidata, Division of OKI America, Inc. All rights reserved. See the OKIDATA Business Partner Exchange (BPX) for any updates to this material. (<http://bpx.okidata.com>)



Service Guide OL810

Chapter 4 Failure Analysis

4.8.06 Engine Test B

The Engine Test B provides the technician with a method for printing the following information, independent of the main controller board.

- Engine Firmware Revision Level
- Modified Page Count
- Fuser Count
- Drum Count
- Actual Page Count

To perform Engine Test B, follow these steps.

1. Remove the upper cover.
2. Override the cover interlock switch and power ON the printer.
3. Allow approximately one minute for the printer to initialize, then press switch SW1 on the engine controller board for three seconds.
4. The printer will start printing the requested data.
5. To stop printing, press switch SW1 on the engine controller board.

Sample



Copyright 1997, Okidata, Division of OKI America, Inc. All rights reserved. See the OKIDATA Business Partner Exchange (BPX) for any updates to this material. (<http://bpx.okidata.com>)

4.8.07 Menu Print

The Menu Print can provide the following information to the service technician.

- Program ROM Revision Level (CU and PU)
- Font ROM Revision Level
- Amount of Printer Page Memory
- Factory Menu Settings
- User Selected Menu Settings

To print the Menu, follow these steps.

1. Power ON the printer and wait for the printer to go ON-LINE.
2. Press the ON-LINE switch to take the printer OFF-LINE.
3. Press the PRINT FONTS/*Print Menu* switch for 3 seconds.
4. The DATA lamp will turn ON, the READY lamp will flash and the message MENU PRINT will be displayed on the operator panel.
5. The Menu will print.
6. When printing is completed, the printer will be OFF-LINE. Press the ON-LINE switch to place the printer ON-LINE.

Sample

OL810 LED PAGE PRINTER

Program ROM : CU 01.92 A00 PU 00.07 FONT 00.16

Page Memory : 4M Bytes Installed

Operator Panel Menu Settings

Level-1

Common	Factory	User
EMULATION	HP LJ III	HP LJ III
COPIES	1	1
PAPER FEED	TRAY1	TRAY1
AUTO TRAY SWITCH	OFF	OFF
TRAY1 PAPER SIZE	UNIVERSAL=A4	UNIVERSAL=A4
TRAY2 PAPER SIZE	UNIVERSAL=A4	UNIVERSAL=A4
HP LaserJet III Emulation		
ORIENTATION	PORTRAIT	PORTRAIT
FONT SOURCE	RESIDENT	RESIDENT
FONT No.	1000	1000
SYMBOL SET	Roman-8	Roman-8
HP CARTRIDGE	NONE	NONE
LINES PER PAGE	60 LINES	60 LINES
A4 PRINT WIDTH	78 COLUMN	78 COLUMN

Level-2

SMOOTHING	ON	ON
PAGE PROTECTION	OFF	OFF
HOST INTERFACE	PARALLEL	RS232C
FLOW CONTROL	DTR HI POLARITY	DTR HI POLARITY
BAUD RATE	9600 BAUD	19200 BAUD
DATA BITS	8 BITS	7 BITS
PARITY	NONE	EVEN
MIN.BUSY TIME	200mSEC	200mSEC
DARKNESS	0	+2
TIME TO QUIET	8 MINUTES	8 MINUTES
AUTO CONTINUE	OFF	OFF
LEGAL LENGTH	14 INCH	14 INCH
LANGUAGE	ENGLISH	ENGLISH

4.8.08 Demo Page Print

NOTE:

Before you select this test, set the PAGE PROTECTION setting in MENU 2 to LETTER.

The Demo Page provides a sample of the capabilities of the printer.

To perform the Demo Page Print, follow these steps.

1. Power ON the printer and wait for the printer to go ON-LINE.
2. Press the ON-LINE switch to take the printer OFF-LINE.
3. Press the NEXT +/*Demo* switch for 3 seconds.
4. The DATA lamp will turn ON, the READY lamp will flash and the message DEMO PAGE PRINT will be displayed on the operator panel.
5. The Demo Page will be printed in approximately one minute.
6. When printing is completed, the printer will be OFF-LINE. Press the ON-LINE switch to place the printer ON-LINE.

Sample

OL810 LED PagePrinter

The **OL810** allows you to print your business documents quickly and quietly. Since the **OL810** has full HP LaserJet® III compatibility, you have instant access to a very large base of business applications. Printer resident scalable fonts support your applications. Bitmap fonts including HP A, B, C, F, L, Y and S1 are standard.

OL810	13 HP LaserJet III Si fonts
	by AGFA Compugraphic
	CG Times
	<i>CG Times Italic</i>
	CG Times Bold
	<i>CG Times Bold Italic</i>
	Univers®
	<i>Univers Italic</i>
	Univers Bold
	<i>Univers Bold Italic</i>
	Univers Condensed
	<i>Univers Italic Condensed</i>
	Univers Bold Condensed
<i>Univers Bold Italic Condensed</i>	
ITC Zapf Dingbats® ☞ ☛ ☜ ☞ ☆	

Font cards with CG Intellifont® fonts, and the AGFA Compugraphic Typeface Library, ensure that your typeface needs are met.

Oki Smoothing Technology provides on-the-fly edge smoothing to reduce the jagged stairstep effect. The output quality is greatly improved.

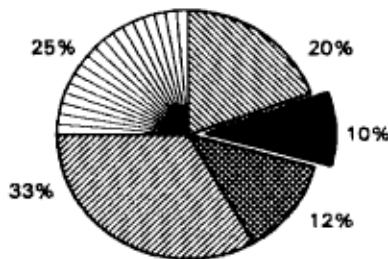

OKI SMOOTHING TECHNOLOGY VECTOR GRAPHICS

The **OL810** is equipped with standard fonts which offer more than HP LaserJet III. The Univers Condensed font provides improved spreadsheet capabilities. The classic ITC Zapf Dingbats adds the power to ☞ ☛ ☜ ☞ ☆. Expandability options include up to 4 MB memory, a second 200 sheet paper tray, scalable and bitmap font cards, a serial interface and Adobe's PostScript® PDL. The **OL810** goes beyond HP LaserJet III. The **OL810** gives you the clear advantage.

HP and LaserJet are registered trademarks of Hewlett-Packard Company. Intellifont is a registered trademark of AGFA Corp., Compugraphic Division. Univers is a registered trademark of Linotype AG and/or its subsidiaries. ITC Zapf Dingbats is a registered trademark of International Typeface Corporation. Adobe and PostScript are registered trademarks of Adobe Systems, Inc.

A.1 OVERVIEW

A.1.01 General Information

This section describes the characteristics of the printed circuit boards in the printer.

The areas listed below are covered.

Firmware

Fuses

Jumpers

Sensors

Switches

Test Points

Where an item is not applicable, the word *NONE* will be listed.

Copyright 1997, Okidata, Division of OKI America, Inc. All rights reserved. See the OKIDATA Business Partner Exchange (BPX) for any updates to this material. (<http://bpx.okidata.com>)

A.2 INDEX TO CHARTS

Main Controller Board	OLMA	A.2.01
Engine Controller Board	LLAT	A.2.02
Operator Panel Board	LLJB-2	A.2.03
Engine Connection Board	LLCC	A.2.04
Second Font Card Board	OLCA	A.2.05
Power Connection Board	LLID	A.2.06
Power Supply Unit	N/A	A.2.07
RS232-C Interface Board Option	OLSA	A.2.08
Memory Boards Options	OLRA or OLRA-2	A.2.09
Second Paper Feed Unit Controller Option	LLFC	A.2.10
Second Paper Feed Unit Connection Option	LLIG	A.2.11
Second Paper Feed Unit Connection Option	LLIF	A.2.12

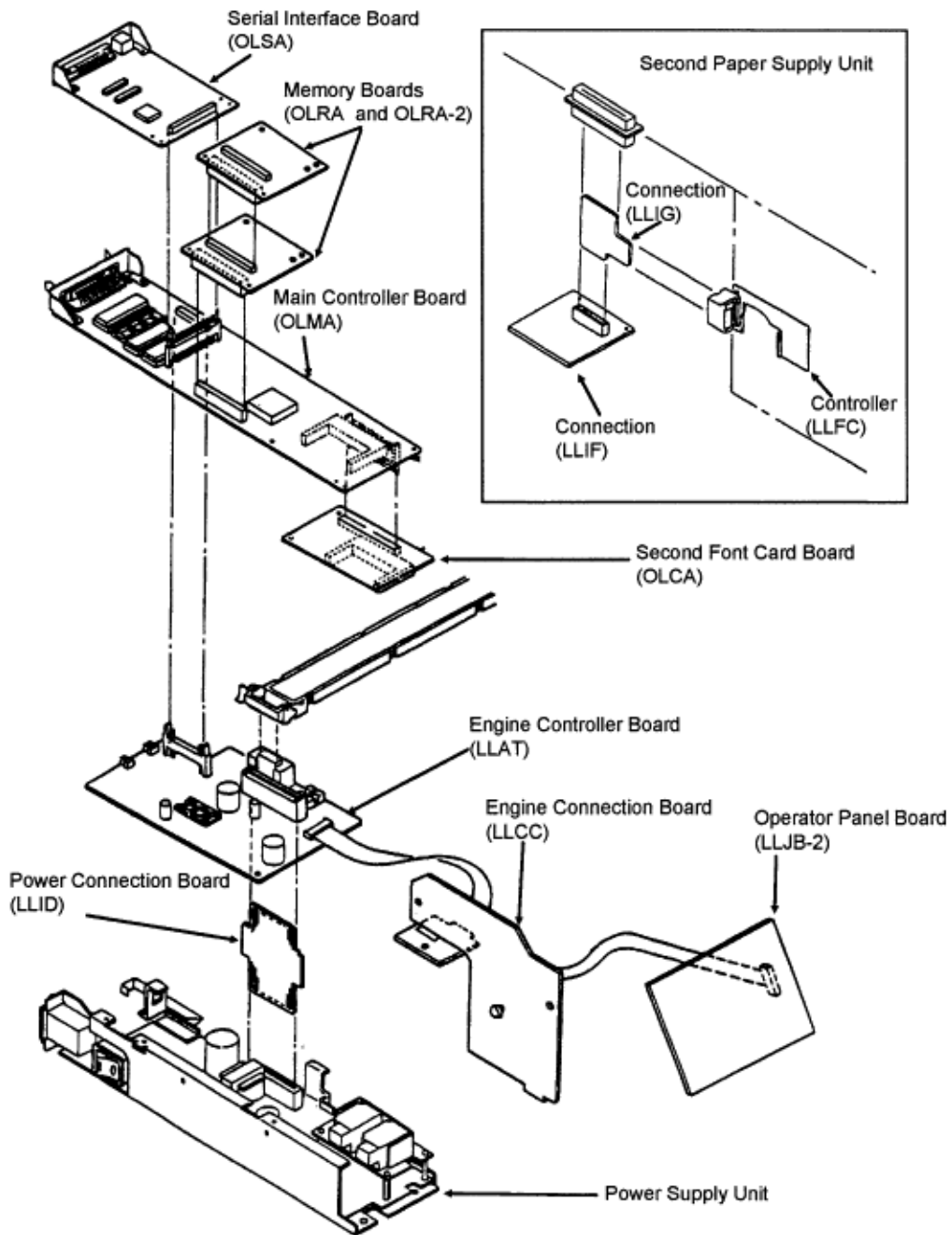

Copyright 1997, Okidata, Division of OKI America, Inc. All rights reserved. See the OKIDATA Business Partner Exchange (BPX) for any updates to this material. (<http://bpx.okidata.com>)

A.2.01 Main Controller Board (OLMA)**Firmware**

02A

Font ROM: contains scalable/bit-mapped font data.

03A

Font ROM: contains scalable/bit-mapped font data.

04A

4 Mbyte, Program ROM

Contains emulation, interface control and error recognition programs.

05A

4 Mbyte, Program ROM

Contains emulation, interface control and error recognition programs.

10E

EEPROM (soldered in at this time): contains protocol/interface settings.

Fuses

F1: 1 amp fuse - (micro-fuse, soldered on the board) protects the +5vdc circuit.

Jumpers*NONE***Sensors***NONE***Switches***NONE***Test Points**

CN1 Pin 18: + 5 vdc

CN6 Pin 30: + 12 vdc

CN6 Pin 15: - 12 vdc

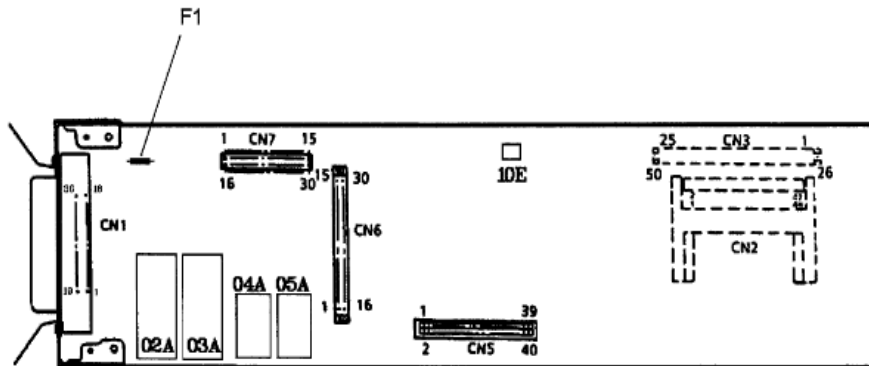

Copyright 1997, Okidata, Division of OKI America, Inc. All rights reserved. See the OKIDATA Business Partner Exchange (BPX) for any updates to this material. (<http://bpx.okidata.com>)

A.2.02 Engine Controller Board (LLAT)**Firmware**

IC2 - EEPROM: contains printer engine settings.

The print engine control program is masked to the microprocessor (IC1).

Fuses

NONE

Jumpers

NONE

Sensors

PT1 - Toner End Sensor

PT2 - Resist Sensor

PS1 - Outlet Sensor

Switches

SW1: used to initialize the Engine Test. Also used during printer adjustments.

Test Points

J6 Pins 13,31,32: + 5 vdc

J6 Pin 12: + 12 vdc

J6 Pin 11: - 12 vdc

J6 Pin 15: + 38 vdc

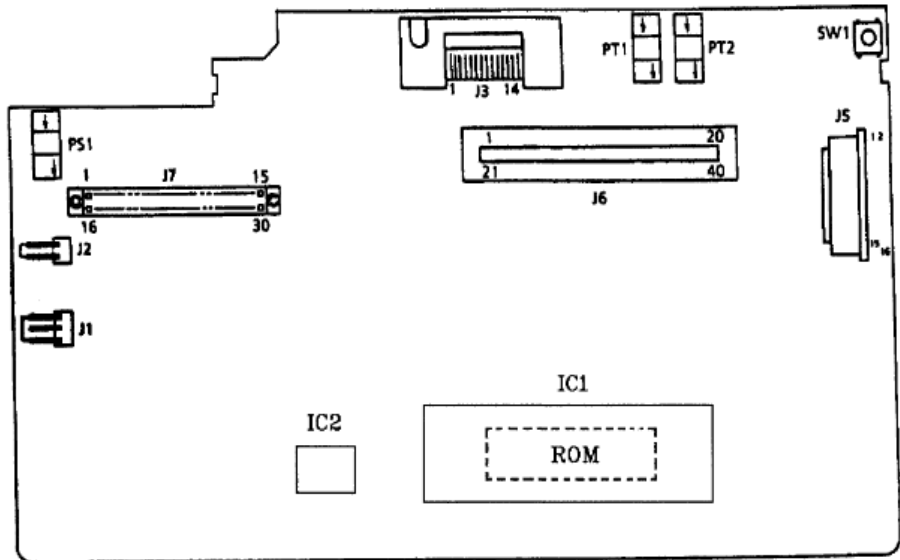

Copyright 1997, Okidata, Division of OKI America, Inc. All rights reserved. See the OKIDATA Business Partner Exchange (BPX) for any updates to this material. (<http://bpx.okidata.com>)

A.2.03 Operator Panel Board (LLJB-2)**Firmware**

NONE

Fuses

NONE

Jumpers

NONE

Sensors

NONE

Switches

SW1 - Next + / Demo

SW2 - LAST - / *Smoothing*

SW3 - ENTER / *Quiet*

SW4 - MENU 1 / *Menu2*

SW5 - ON-LINE

SW6 - FORM FEED / *Tray Select*

SW7 - PRINT FONTS / *Print Menu*

SW8 - RECOVER / *Reset*

Test Points

NONE

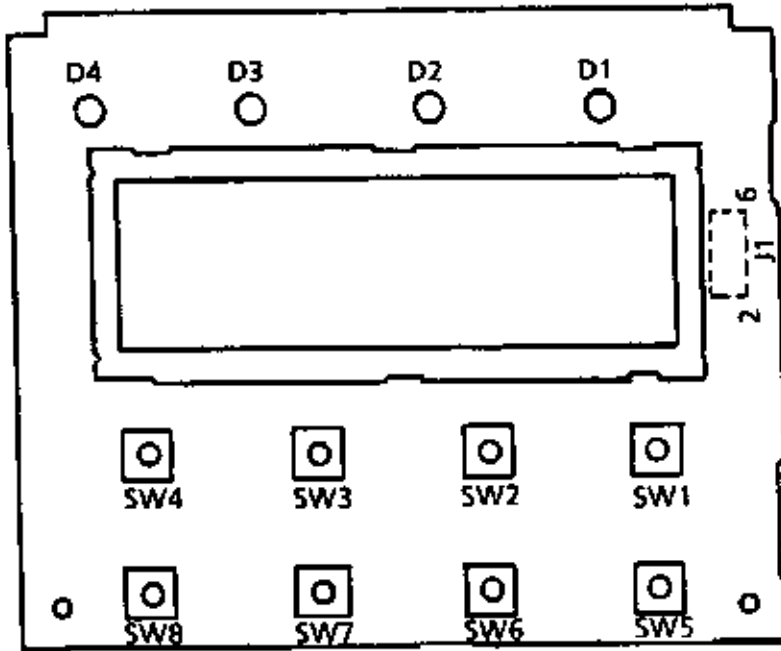

Copyright 1997, Okidata, Division of OKI America, Inc. All rights reserved. See the OKIDATA Business Partner Exchange (BPX) for any updates to this material. (<http://bpx.okidata.com>)

A.2.04 Engine Connection Board (LLCC)**Firmware***NONE***Fuses***NONE***Jumpers***NONE***Sensors**

SEN1: Paper-end sensor

Switches

SW1, SW2 and SW3: tray size detection switches

Test Points*NONE*

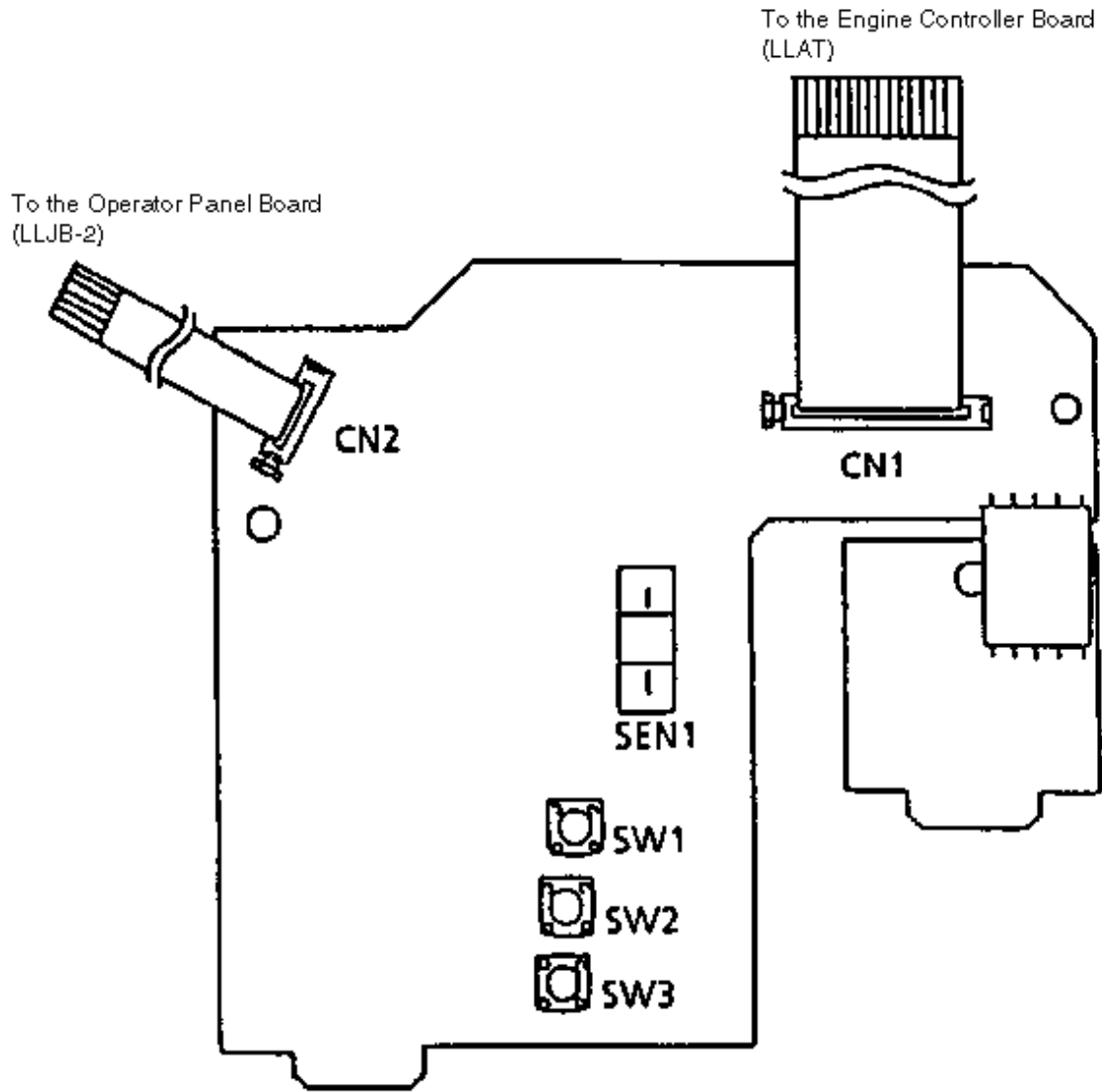

Copyright 1997, Okidata, Division of OKI America, Inc. All rights reserved. See the OKIDATA Business Partner Exchange (BPX) for any updates to this material. (<http://bpx.okidata.com>)

A.2.05 Second Font Card Board (OLCA)**Firmware***NONE***Fuses***NONE***Jumpers***NONE***Sensors***NONE***Switches***NONE***Test Points***NONE*

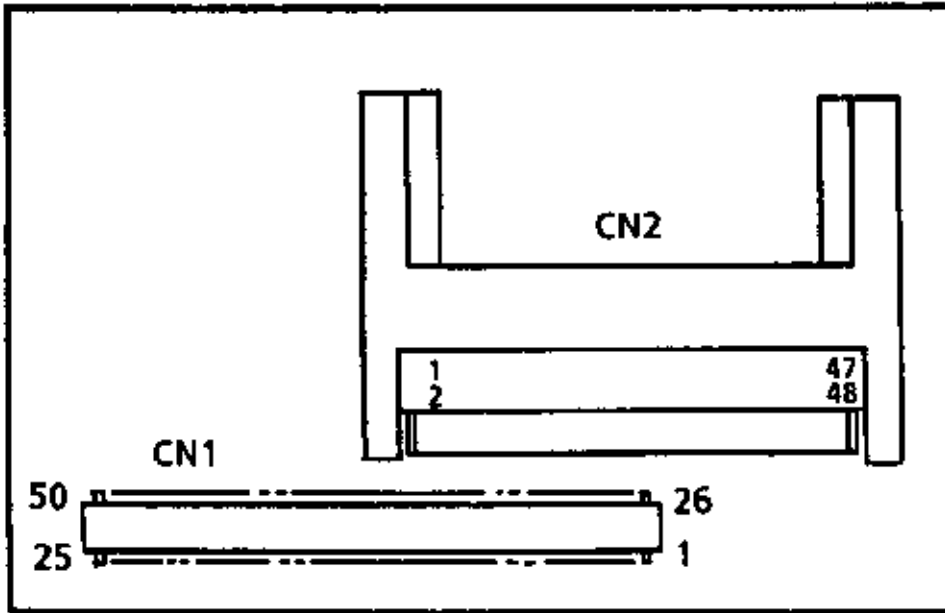

Copyright 1997, Okidata, Division of OKI America, Inc. All rights reserved. See the OKIDATA Business Partner Exchange (BPX) for any updates to this material. (<http://bpx.okidata.com>)

A.2.06 Power Connection Board (LLID)**Firmware***NONE***Fuses***NONE***Jumpers***NONE***Sensors***NONE***Switches***NONE***Test Points***NONE*

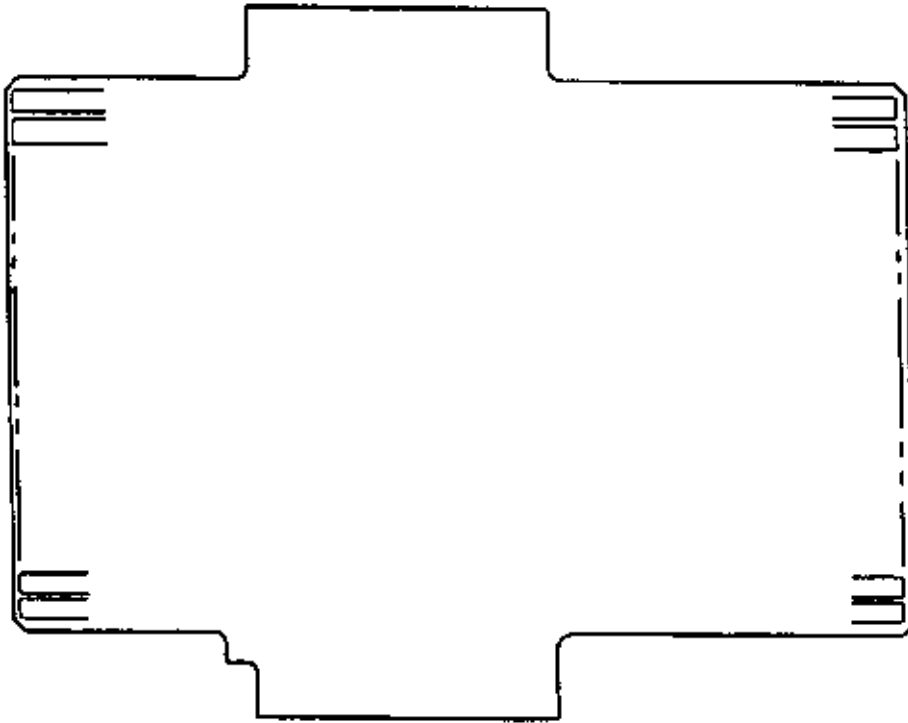

Copyright 1997, Okidata, Division of OKI America, Inc. All rights reserved. See the OKIDATA Business Partner Exchange (BPX) for any updates to this material. (<http://bpx.okidata.com>)

A.2.07 Power Supply Unit**Firmware**

NONE

Fuses

F2: 125 Volt 2 amp fuse

Micro-fuse, soldered on the board

Protects the + 38 vdc circuit.

F1: 250Volt 8 amp - AC line fuse

Jumpers

NONE

Sensors

NONE

Switches

SW1: Power switch

SW2: Cover open switch

If open, disables both the + 38 vdc and the high voltage circuit

Test Points

CN1 Pin 15: + 38 vdc

CN1 Pins 13,31,32: + 5 vdc

CN1 Pin 12: + 12 vdc

CN1 Pin 11: - 12 vdc

CN1 Pin 37: (HEAT signal) received from the engine controller board.

When this signal is approximately +3.25 vdc, the power supply unit will supply AC voltage to the fuser lamp.

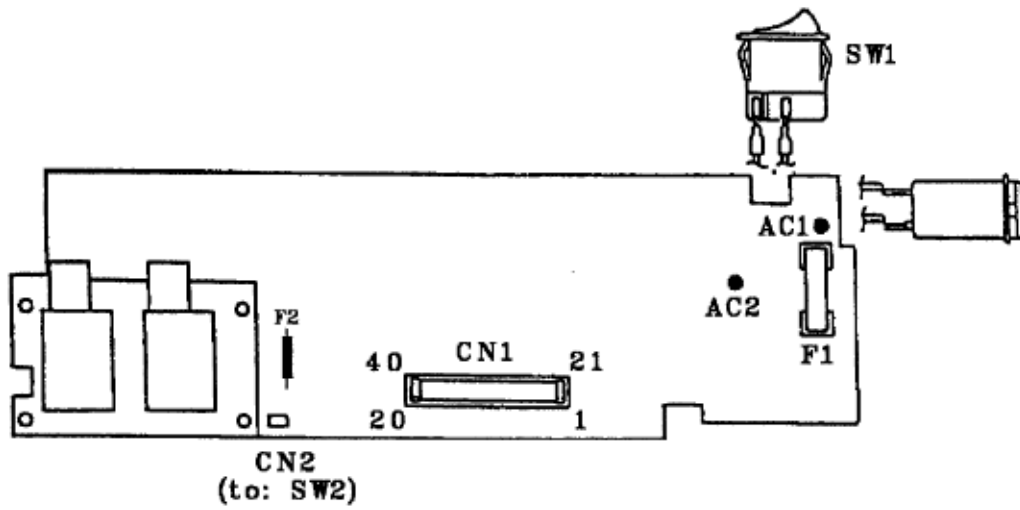

Copyright 1997, Okidata, Division of OKI America, Inc. All rights reserved. See the OKIDATA Business Partner Exchange (BPX) for any updates to this material. (<http://bpx.okidata.com>)

A.2.08 RS232-C Interface Board (OLSA) Option**Firmware***NONE***Fuses***NONE***Jumpers***NONE***Sensors***NONE***Switches***NONE***Test Points**

CN3 Pin30: +12vdc

CN3 Pin 15: -12vdc

CN3 Pins 12,13,14: +5vdc

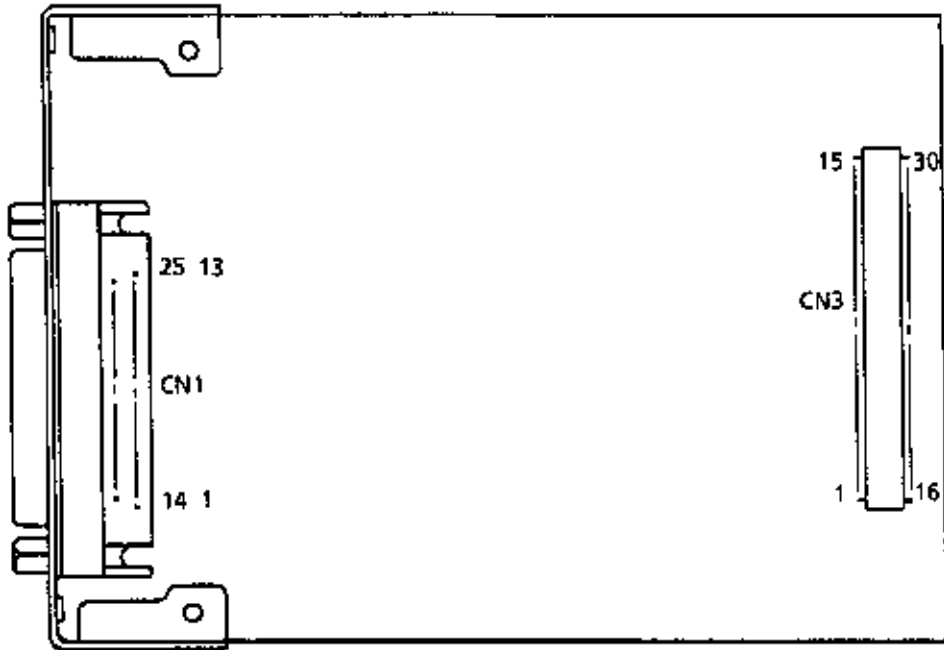

Copyright 1997, Okidata, Division of OKI America, Inc. All rights reserved. See the OKIDATA Business Partner Exchange (BPX) for any updates to this material. (<http://bpx.okidata.com>)



Service Guide OL810

Chapter A Board Diagrams

A.2.09 Memory Boards (OLRA and OLRA-2) Options

NOTES:

The memory boards are sometimes referred to as RAM expansion boards.

Installing these boards increases the amount of available RAM.

The printer contains 1 megabyte of RAM, standard.

Two optional memory boards can be installed at the same time in the OL810.

The OLRA memory board increases available RAM by 2 megabytes.

The OLRA-2 memory board increases available RAM by 1 megabyte.

Total installed RAM cannot exceed 5 Mbyte

Standard Memory (1 Mbyte) Optional OLRA-2 (1 Mbyte) Optional OLRA-2 (1 Mbyte) Optional OLRA (2 Mbyte) Optional OLRA (2 Mbyte) Total Memory

Installed 1 Mbyte Installed 2 Mbyte Installed 3 Mbyte Installed 4 Mbyte Installed 5 Mbyte
 Installed 3 Mbyte Installed 4 Mbyte Installed 5 Mbyte

Firmware

NONE

Fuses

NONE

Jumpers

NONE

Sensors

NONE

Switches

NONE

Test Points

NONE

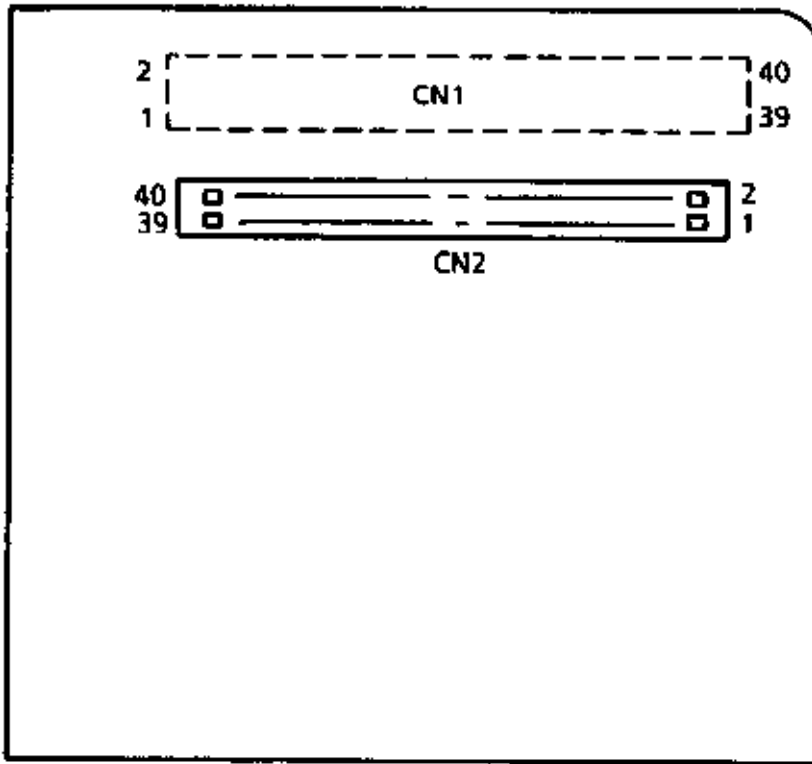

Copyright 1997, Okidata, Division of OKI America, Inc. All rights reserved. See the OKIDATA Business Partner Exchange (BPX) for any updates to this material. (<http://bpx.okidata.com>)

A.2.10 Second Paper Feed Unit Controller (LLFC) Option**Firmware***NONE***Fuses**

F1: 125 Volt 1 amp fuse Micro-fuse, soldered on the board Protects the +38vdc circuit.

Jumpers*NONE***Sensors**

SEN-1: Paper-end sensor for second paper tray

Switches

SW1, SW2 and SW3: Tray size detection switches

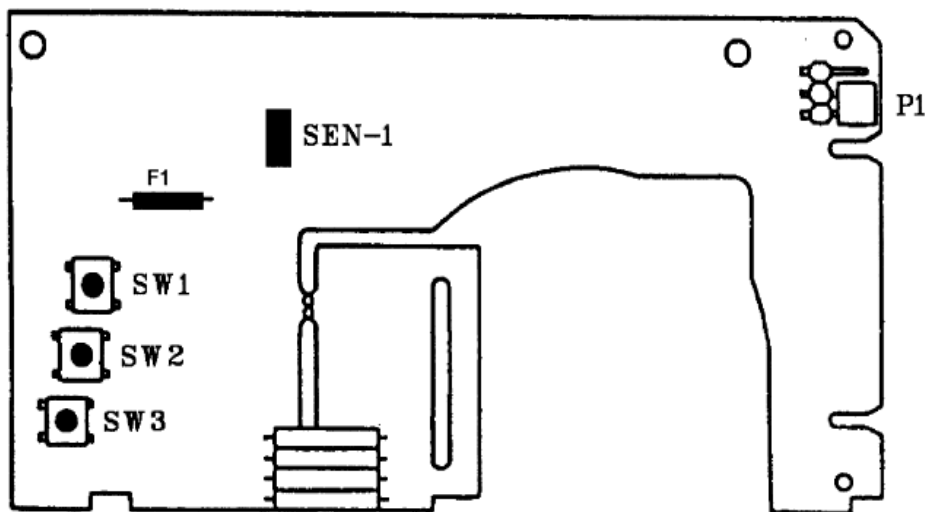
Test Points*NONE*

Copyright 1997, Okidata, Division of OKI America, Inc. All rights reserved. See the OKIDATA Business Partner Exchange (BPX) for any updates to this material. (<http://bpx.okidata.com>)

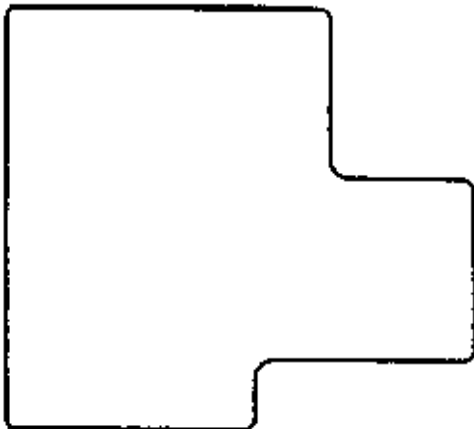
A.2.11 Second Paper Feed Unit Connection Board (LLIG) Option**Firmware***NONE***Fuses***NONE***Jumpers***NONE***Sensors***NONE***Switches***NONE***Test Points***NONE*

A.2.12 Second Paper Feed Unit Connection Board (LLIF) Option

Firmware

NONE

Fuses

NONE

Jumpers

NONE

Sensors

NONE

Switches

NONE

Test Points

NONE

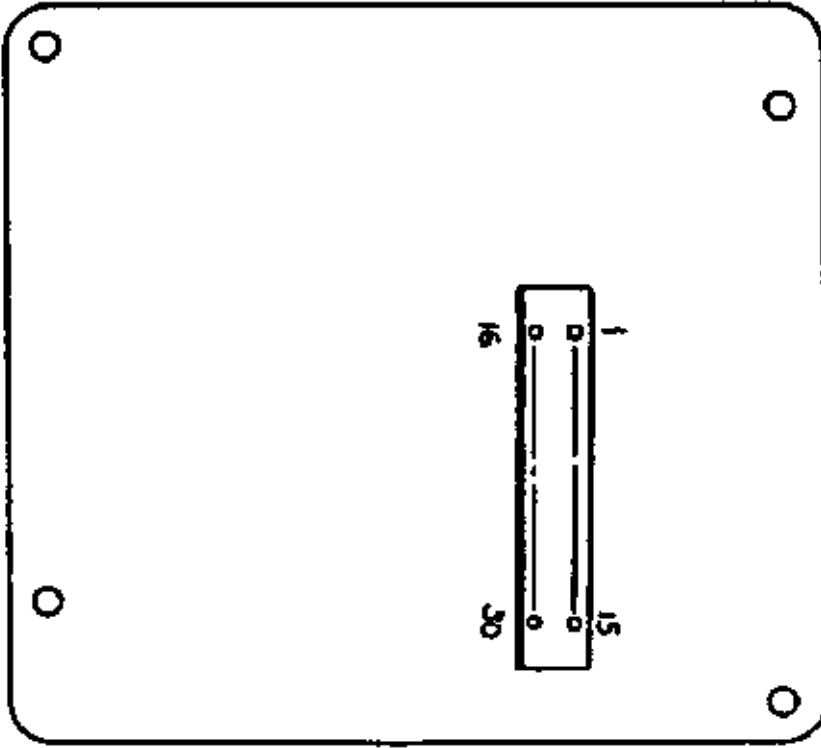

Copyright 1997, Okidata, Division of OKI America, Inc. All rights reserved. See the OKIDATA Business Partner Exchange (BPX) for any updates to this material. (<http://bpx.okidata.com>)



Service Guide OL810

Chapter B Illustrated Parts Listing

B.1 OVERVIEW

B.1.01 General Information

This appendix will assist you in identifying the assemblies and parts of the product.

Use Section Four (Failure Analysis) to determine the defective part(s).

Locate the part and its part number in this section.

Appendix B is cross-referenced to Section Three (Maintenance).

Format

The format for this appendix is a series of tables with diagrams. The tables contain the item reference number, the Okidata and Oki-Japan (Oki-J) part numbers, the part description, a comments section, and the disassembly procedure.

Item	Okidata P/N Oki-J P/N	Description	Comments Refer to B.1.02	Disassembly Procedure
------	--------------------------	-------------	-----------------------------	--------------------------

Items with the comments RSPL (Recommended Spare Parts List), Consumable, Document, or Option are available from Okidata. Items without these comments are usually not stocked.

Some items are only available as assemblies. Every effort has been made to clearly indicate which items are in assemblies and which are not.

N/A will appear where a part number is not available.

Current Part Numbers

Okidata has made every effort to include current part numbers in this Service Handbook *at the time of publishing*.

However, technical information frequently changes. These changes often include new or modified parts, with new or modified part numbers.

Please refer to the following resources for current part numbers and pricing.

- Okidatas Electronic Bulletin Board (Okilink II) contains current part numbers, prices, and recommended stocking levels for each item listed as a recommended spare part. For instructions on accessing Okilink II, refer to the Service Center Reference Guide.

- Okidatas Faxeable Facts is an automated fax document retrieval system. Part numbers and pricing are available through Faxeable Facts. For instructions on accessing Faxeable Facts, refer to the Service Center Reference Guide.

· Okidatas Technical Information Group is a telephone support line reserved for Authorized Dealers. Part numbers and pricing are available through Technical Information. For instructions on accessing Technical Information, refer to the Service Center Reference Guide.

REMEMBER

Current part numbers, recommended stocking levels, and pricing information are available through Okilink II, Faxable Facts, and Technical Information. Refer to the Service Center Reference Guide for information on accessing these resources.

Copyright 1997, Okidata, Division of OKI America, Inc. All rights reserved. See the OKIDATA Business Partner Exchange (BPX) for any updates to this material. (<http://bpx.okidata.com>)

B.1.02 Definition of Terms

Assemblies

Assemblies are parts grouped under a single description and/or part number. Generally, individual items in an assembly are not available from Okidata.

Assemblies are surrounded by broken line boxes in the diagrams.

Assemblies will say "Includes xx xx" under the *Comments* section of the tables.

Parts in assemblies will say "Part of xx" under the *Comments* section of the tables.

Blank

Okidata does not recommend stocking this item. This item should be purchased on an **As**

Required Basis *only*.

The availability of this item is *NOT* guaranteed by Okidata.

Consumable

A consumable is a supply item which has a specified life and must be periodically replaced. It is purchased and installed by the end user. Okidata machines are designed to work *exclusively* with Okidata consumables. By using genuine Okidata consumable products, the investment made in the equipment is protected.

Document

A document is a printed item which supports the service and marketing of a product. Various documents are available from Okidata.

Drivers

Printer drivers are updated frequently. Please refer to Okilink II for the latest printer driver information.

Firmware

Firmware is revised frequently. Please refer to Okilink II for the latest firmware information.

Option

An option is a part/assembly which is added to a product. The option expands the products functionality. An option may or may not be installed by the end user. Instructions for installation accompany each option.

Option RSPL

Okidata recommends that this part/assembly be on hand for servicing installed options.

RSPL

Okidata recommends that this part/assembly be on hand for servicing.

Technical Service Bulletins

Technical Service Bulletins (TSBs) are also referred to as Okidata's monthly mail. The TSBs contain the latest information on firmware revisions, procedure changes, and technical information updates.

Okidata distributes the TSBs through Okilink II. The TSBs are issued monthly.

Copyright 1997, Okidata, Division of OKI America, Inc. All rights reserved. See the OKIDATA Business Partner Exchange (BPX) for any updates to this material. (<http://bpx.okidata.com>)

B.1.03 Parts Ordering Information

Service Center Reference Guide

When a technician has successfully completed a Service Training Course for a product and the Dealer has become Service Authorized, an information package is provided to the Dealer. The Okidata Service Center Reference Guide outlines the following items.

- Responsibilities of Okidata Service Centers
- Spare parts and consumables information
- Procedures for warranty repairs
- Product Training, Certification, and Authorization
- Product Support information
- Okidata Depot information and services
- Third Party Service information
- Information about Okidata's Customer Information Center
- Okidata Service and Support telephone numbers.

The Service Center Reference Guide contains the procedures to follow for ordering parts. Please *read, understand, and follow* these procedures. Service Authorization for a specific product *must* be obtained before a Dealer can submit warranty claims.

Direct questions regarding the Service Center Reference Guide to Okidata Dealer Service. Refer to the Service Center Reference Guide for information on contacting Okidata.

Placing a Parts Order

All authorized Okidata resellers may order spare parts and consumables for Okidata products.

Orders are placed through Okidata's Logistics Department.

Please refer to your Service Center Reference Guide for details on ordering parts.

You should have the following information available *before* you place your order.

- Okidata Dealer Authorization Number
- Okidata Customer Number

- Your Purchase Order Number

- Okidata Part Number(s)

Use this Appendix, Okilink II, Faxable Facts, or contact Okidata Technical Support to find the correct part number. Refer to the Service Center Reference Guide for information on contacting Okidata.

Copyright 1997, Okidata, Division of OKI America, Inc. All rights reserved. See the OKIDATA Business Partner Exchange (BPX) for any updates to this material. (<http://bpx.okidata.com>)



Service Guide OL810

Chapter B Illustrated Parts Listing

B.2 CHARTS

Below is an index to the illustrated parts breakdown charts.

Description	Section
Printer	B.2.01
Printer Unit	B.2.02
Paper Trays	B.2.03
Upper Unit (1 of 2)	B.2.04
Upper Unit (2 of 2)	B.2.05
LED Holder	B.2.06
Lower Unit (1 of 2)	B.2.07
Lower Unit (2 of 2)	B.2.08
Boards	B.2.09
Paper Eject Roller Assembly	B.2.10
Paper Supply Unit	B.2.11
Options	B.2.12
Font Cards	B.2.13
Second Paper Feed Unit	B.2.14
Packing Materials	B.2.15
Consumables	B.2.16
Documentation	B.2.17
Service Training Kit Revisions	B.2.18



Service Guide OL810

Chapter B Illustrated Parts Listing

B.2.01 Printer

Part numbers are subject to change. Refer to Okilink II for current part numbers and pricing information.

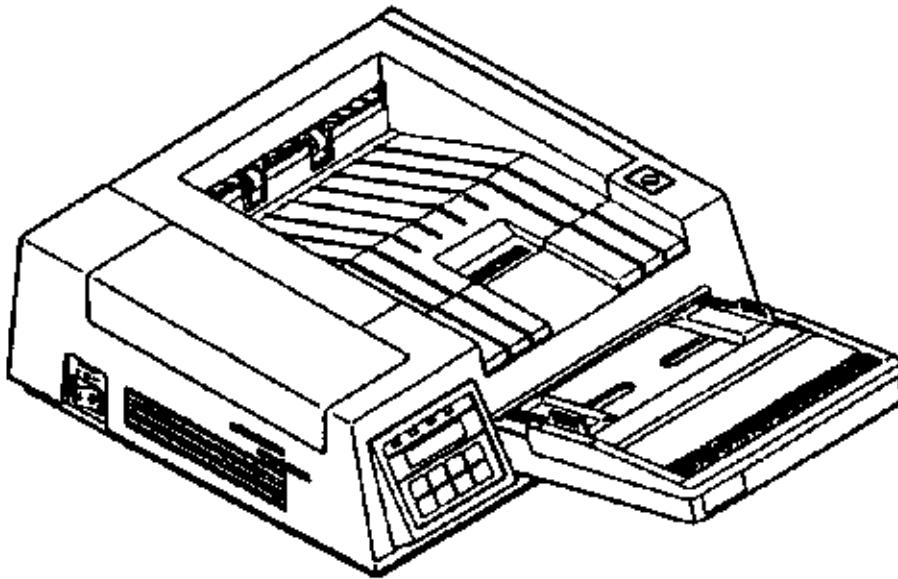

Item	Okidata P/N Oki-J P/N	Description	Comments Refer to B.1.02	Disassembly Procedure
1	62409601	Printer: OL810 Parallel 120 V		N/A
1	62409602	Printer: OL810 Serial 220/240V		N/A



Service Guide OL810
 Chapter B Illustrated Parts Listing

B.2.02 Printer Unit

Part numbers are subject to change. Refer to Okilink II for current part numbers and pricing information.

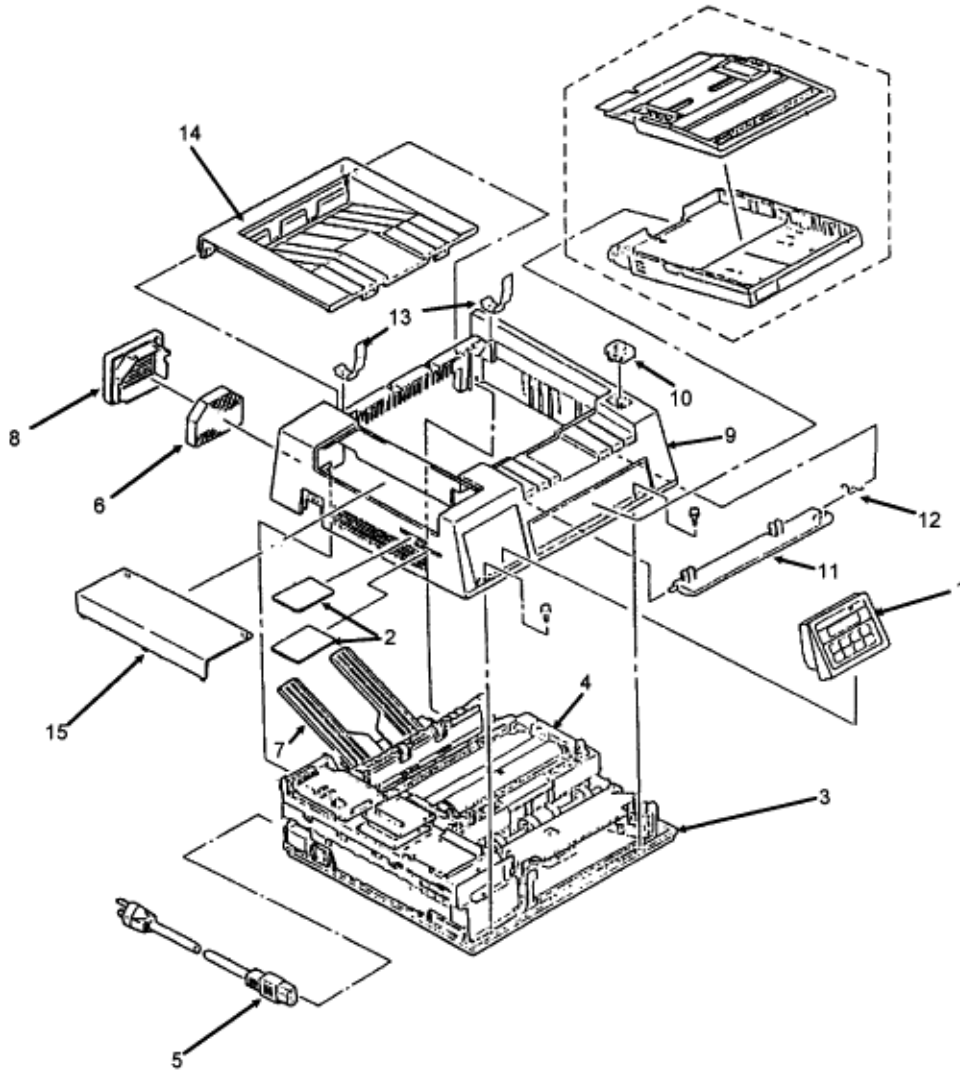

Item	Okidata P/N Oki-J P/N	Description	Comments Refer to B.1.02	Disassembly Procedure
1	50213508 4YA4083-5012G8	Panel: Operator Assembly (OL810)	RSPL	3.2.02

2	70014501 4YB4060-4145P20	Font ROM Card (Letter Gothic)	Option	3.2.01
2	70014201 4YB4060-4145P18	Font ROM Card (Prestige Elite)	Option	3.2.01
2	70014401 4YB4060-4144P7	Font ROM Card (Tax)	Option	3.2.01
3	50213602 1YX4083-2002G2	Unit: Lower	RSPL	3.2.02
4	50213706 1YX4083-2060G6	Unit: Upper (120V)	RSPL	3.2.16
4	50213707 1YX4083-2060G7	Unit: Upper (220/240V)	Option	3.2.16
5	56609701 3YS4011-1315P1	Cord: AC (120V)	RSPL	3.2.01
5	56624301 3YS4011-1266P1	Cord: AC (220V)	Option	3.2.01
5	56624501 3YS4011-1270P1	Cord: AC 240 V (OL Series) UK	Option	3.2.01
6	55503501 3PB4083-2816P2	Filter: Ozone	Consumable Part of	3.2.36
7	50066601 2PA4083-2055G1	Stacker: Face-up Assembly	RSPL	3.2.02
8	53527301 2PP4016-6836P1	Fan Cover		3.2.36
9	53338203 1PP4083-3243G3	Cover: Upper w/logo (OL810)	RSPL	3.2.02
10	53527401 3PP4016-6832P1	Button		3.2.03
11	51111301 2PP4016-6831P1	Shaft		3.2.03
12	50917901 4PP4016-6833P1	Spring		3.2.03
13	50918001 4PP4083-2585P1	Reset Spring		3.2.02
14	N/A 2PA4083-3225G1	Stacker Cover Assembly		3.2.02
15	N/A IPP4083-3223P1	Access Cover		3.2.02

16 *	52046506 4PB4012-2589P1	Logo: Plate OL810	RSPL	3.2.02
17 *	52054004 3PB4012-3519P1	Touch Sheet: Op Panel (OL810)	RSPL	3.2.02

* This item is not shown.

Copyright 1997, Okidata, Division of OKI America, Inc. All rights reserved. See the OKIDATA Business Partner Exchange (BPX) for any updates to this material. (<http://bpx.okidata.com>)

B.2.03 Paper Trays

Part numbers are subject to change. Refer to Okilink II for current part numbers and pricing information.

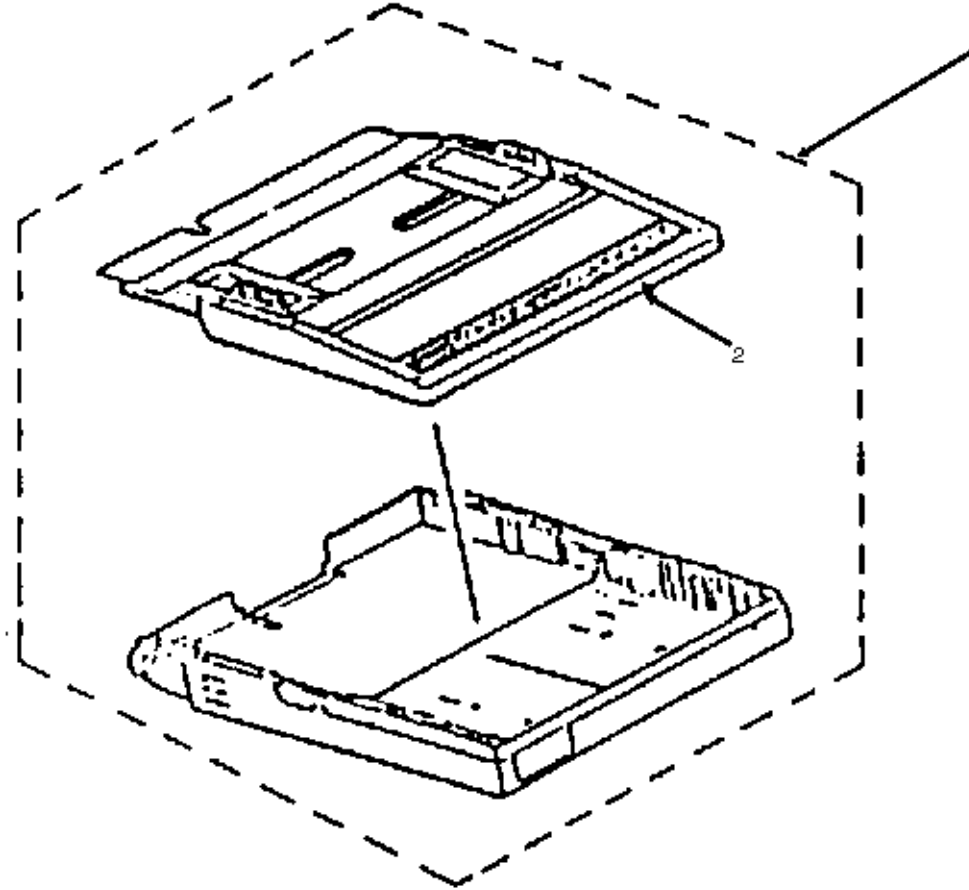

Item	Okidata P/N Oki-J P/N	Description	Comments Refer to B.1.02	Disassembly Procedure
1	70016701 4YA4083-2414G1	Paper Tray (A4)	Option	3.2.01
1	70013801 4YA4083-2419G2	Paper Tray (Envelope)	Option	3.2.01
1	70016801 4YA4083-2418G1	Paper Tray (Executive)	Option	3.2.01

1	70013701 4YA4083-3207G8	Paper Tray (Legal)	Option	3.2.01
1	70013601 4YA4083-2120G1	Paper Tray (Letter)	RSPL / Option	3.2.01
1	70021901 4YA4083-3206G1	Paper Tray (Universal)	Option	3.2.01
2	53527602 1PA4083-2321G2	Tray Cover (Legal)	Option RSPL	3.2.01
2	53527601 1PA4083-2321G1	Tray Cover (Letter)	RSPL / Option	3.2.01

Copyright 1997, Okidata, Division of OKI America, Inc. All rights reserved. See the OKIDATA Business Partner Exchange (BPX) for any updates to this material. (<http://bpx.okidata.com>)

B.2.04 Upper Unit (1 of 2)

Part numbers are subject to change. Refer to Okilink II for current part numbers and pricing information.

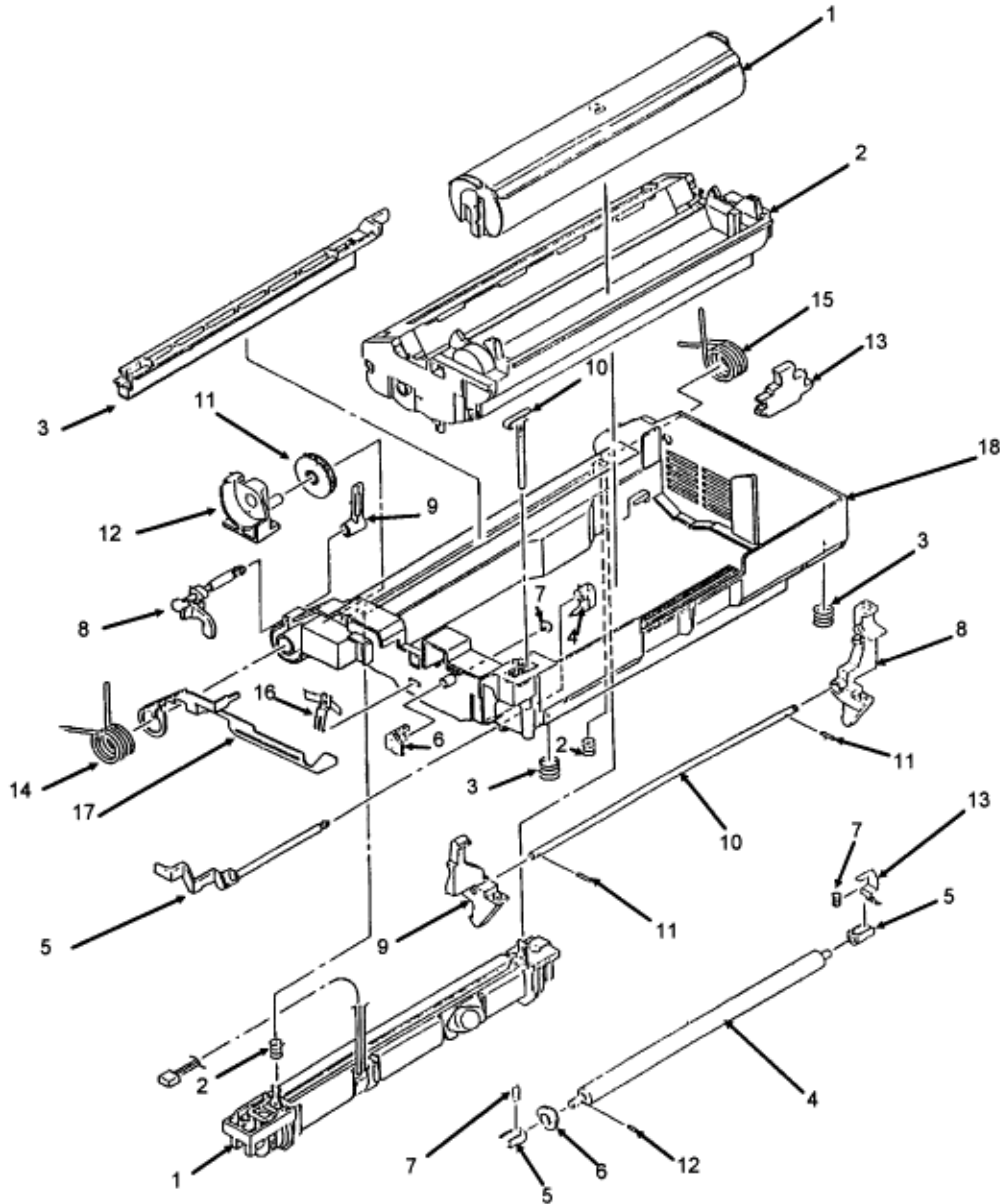

Item	Okidata P/N Oki-J P/N	Description	Comments Refer to B.1.02	Disassembly Procedure
1	52104201 4YA4083-3202G1	Toner Cartridge Kit	Consumable Inc 3	3.2.01
2	56106601 4YA4083-3201G1	Image Drum Kit	Consumable	3.2.01
3	53500901 3PB4083-2096P1	Pad: Fuser	Consumable Part of 1	3.2.19
4	53503001 4PP4083-2068P1	Sensor Lever (Resist)		3.2.21
5	53329601 3PP4083-2069P1	Sensor Flag (Resist)		3.2.21
6	53527701 4PP4083-2732G1	Sensor Lever (Toner)		3.2.21
7	50606001 4PP4083-2584P1	Rivet		3.2.21
8	53527801 4PP4083-2578P1	Paper Eject Sensor Lever B		3.2.18
9	53527901 4PP4083-2589P1	Paper Eject Sensor Lever C		3.2.18
10	50312501 4PP4083-2095P1	Actuator		3.2.17
11	51218501 4PP4083-3130P1	Gear: Idle "B"	RSPL	3.2.16
12	51005001 3PP4083-2092P1	Fulcrum Block		3.2.16
13	53528001 4PP4083-2757G1	Transfer Wire Cleaner		3.2.26
14	50918101 4PP4083-2093P1	Torsion Spring (Left)		3.2.12 16
15	50918201 4PP4083-2094P1	Torsion Spring (Right)		3.2.16
16	53058201 4PP4083-2067P1	Ground Plate (Drum)		3.2.23
17	53058901 3PP4083-2065P1	Support Plate (Left)		3.2.23
18	53329701 1PP4083-2061P1	Upper Frame		3.2.23

Copyright 1997, Okidata, Division of OKI America, Inc. All rights reserved. See the OKIDATA Business Partner Exchange (BPX) for any updates to this material. (<http://bpx.okidata.com>)



Service Guide OL810
Chapter B Illustrated Parts Listing



Copyright 1997, Okidata, Division of OKI America, Inc. All rights reserved. See the OKIDATA Business Partner Exchange (BPX) for any updates to this material. (<http://bpx.okidata.com>)

B.2.05 Upper Unit (2 of 2)

Part numbers are subject to change. Refer to Okilink II for current part numbers and pricing information.

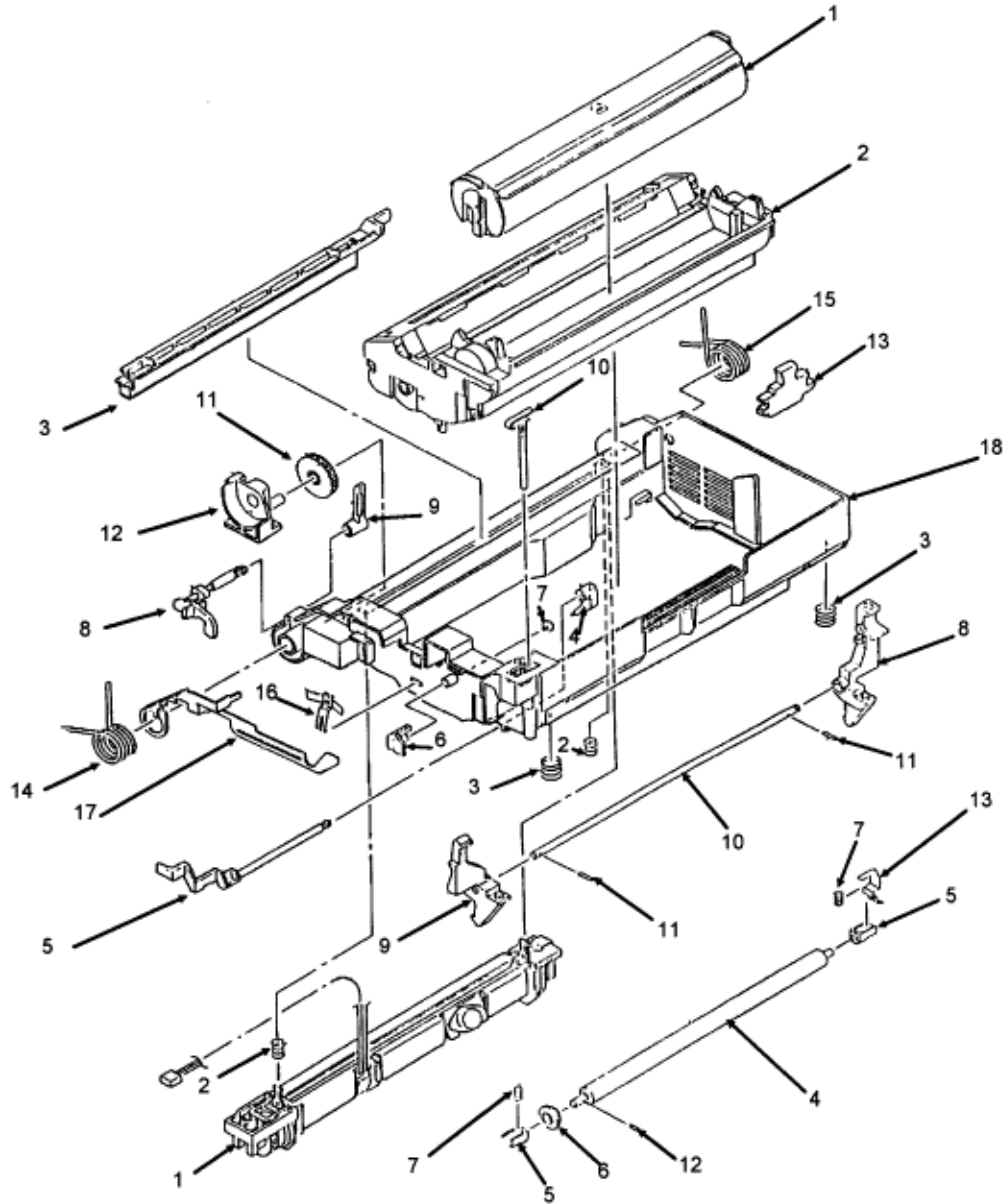

Item	Okidata P/N Oki-J P/N	Description	Comments Refer to B.1.02	Disassembly Procedure
1	55044901 2YX4083-2073G1	Unit: Fusing (120V)	RSPL	3.2.19
1	55044902 2YX4083-2073G4	Unit: Fusing (220/240V)	Option RSPL	3.2.19
2	50914601 4PP4083-2091P1	Spring: Fusing Unit	RSPL	3.2.19
3	50917205 LB-121200-5	Spring: Image Drum Tray	RSPL	3.2.22
4	53334302 4PP4083-2848P2	Pressure Roller		3.2.20
5	51605802 4PP4083-2071P2	Bearing		3.2.20
6	51222701 4PP4083-2819P1	Pressure Roller Gear		3.2.20
7	50914501 4PP4083-2072P1	Pressure Spring		3.2.20
8	53502601 3PP4083-2062P1	Lock Lever (Left)		3.2.22
9	53502701 3PP4083-2063P1	Lock Lever (Right)		3.2.22
10	51110201 4PP4083-2064P1	Lock Lever Shaft		3.2.22
11	50606216 NK2-16-SUS	Knock Pin		3.2.22
12	50606208 NK1-6-8-SUS	Knock Pin		3.2.20
13	56729701 4PP4083-2066P1	Ground Plate (Resist)		3.2.20

Copyright 1997, Okidata, Division of OKI America, Inc. All rights reserved. See the OKIDATA Business Partner Exchange (BPX) for any updates to this material. (<http://bpx.okidata.com>)

B.2.06 LED Holder

Part numbers are subject to change. Refer to Okilink II for current part numbers and pricing information.

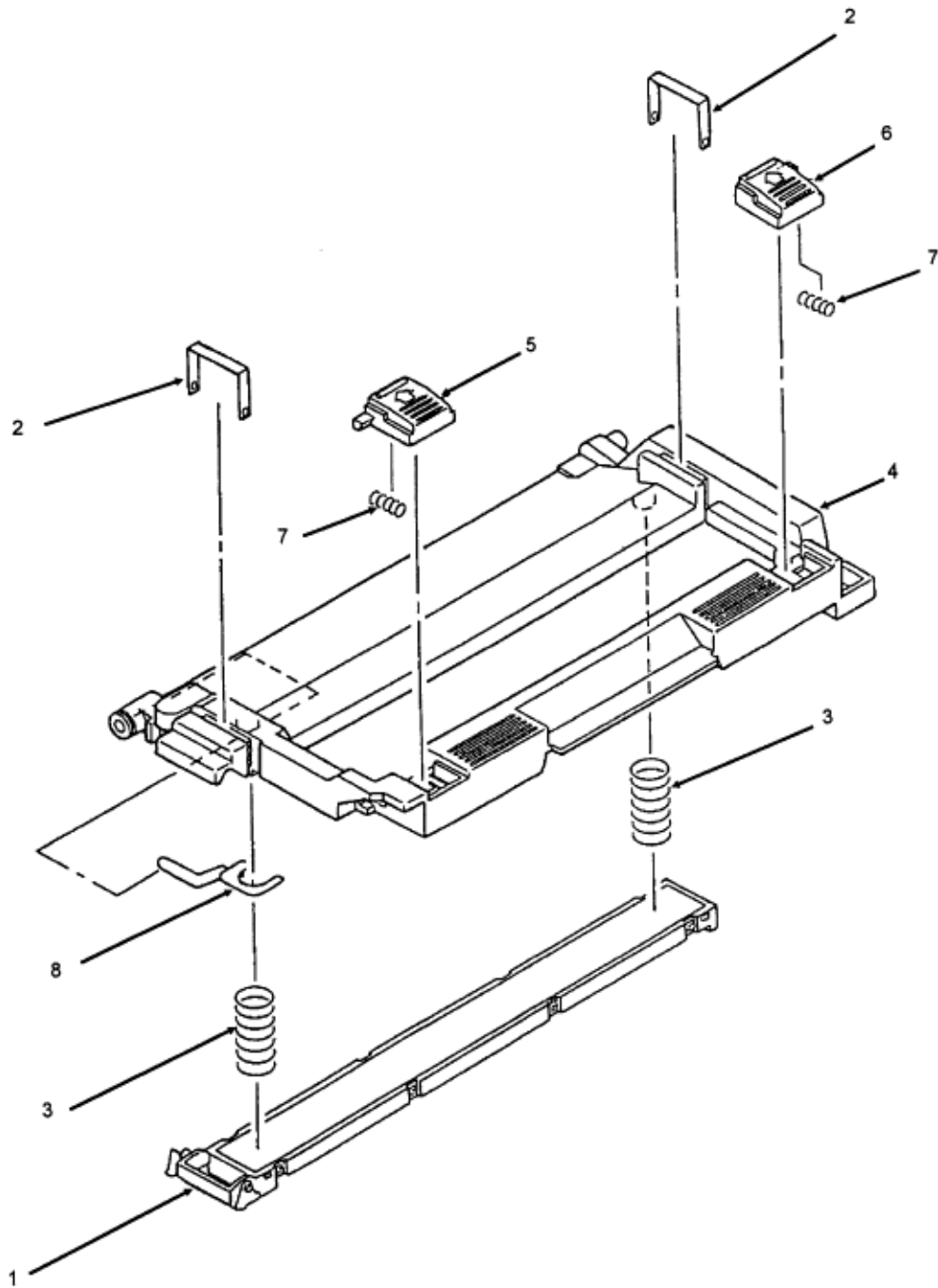

Item	Okidata P/N Oki-J P/N	Description	Comments Refer to B.1.02	Disassembly Procedure
1	55622301 4YA4116-1101G1	Unit: LED Head (300 dpi OST)	RSPL	3.2.04

2	50914301 4PP4083-2099P1	Spring: Clamp (LED)	RSPL	3.2.04
3	50914101 4PP4083-2088P1	Spring: Bias (LED Head)	RSPL	3.2.04
4	55619601 4PP4083-2087P1	LED Head Housing		3.2.23
5	51901301 3PP4083-2594P1	Knob (Left)		3.2.24
6	51901401 3PP4083-2595P1	Knob (Right)		3.2.24
7	50918301 4PP4083-2596P1	Pressure Spring		3.2.24
8	53058401 4PP4083-2090P1	Ground Plate (LED Head)		3.2.24

Copyright 1997, Okidata, Division of OKI America, Inc. All rights reserved. See the OKIDATA Business Partner Exchange (BPX) for any updates to this material. (<http://bpx.okidata.com>)

B.2.07 Lower Unit (1 of 2)

Part numbers are subject to change. Refer to Okilink II for current part numbers and pricing information.

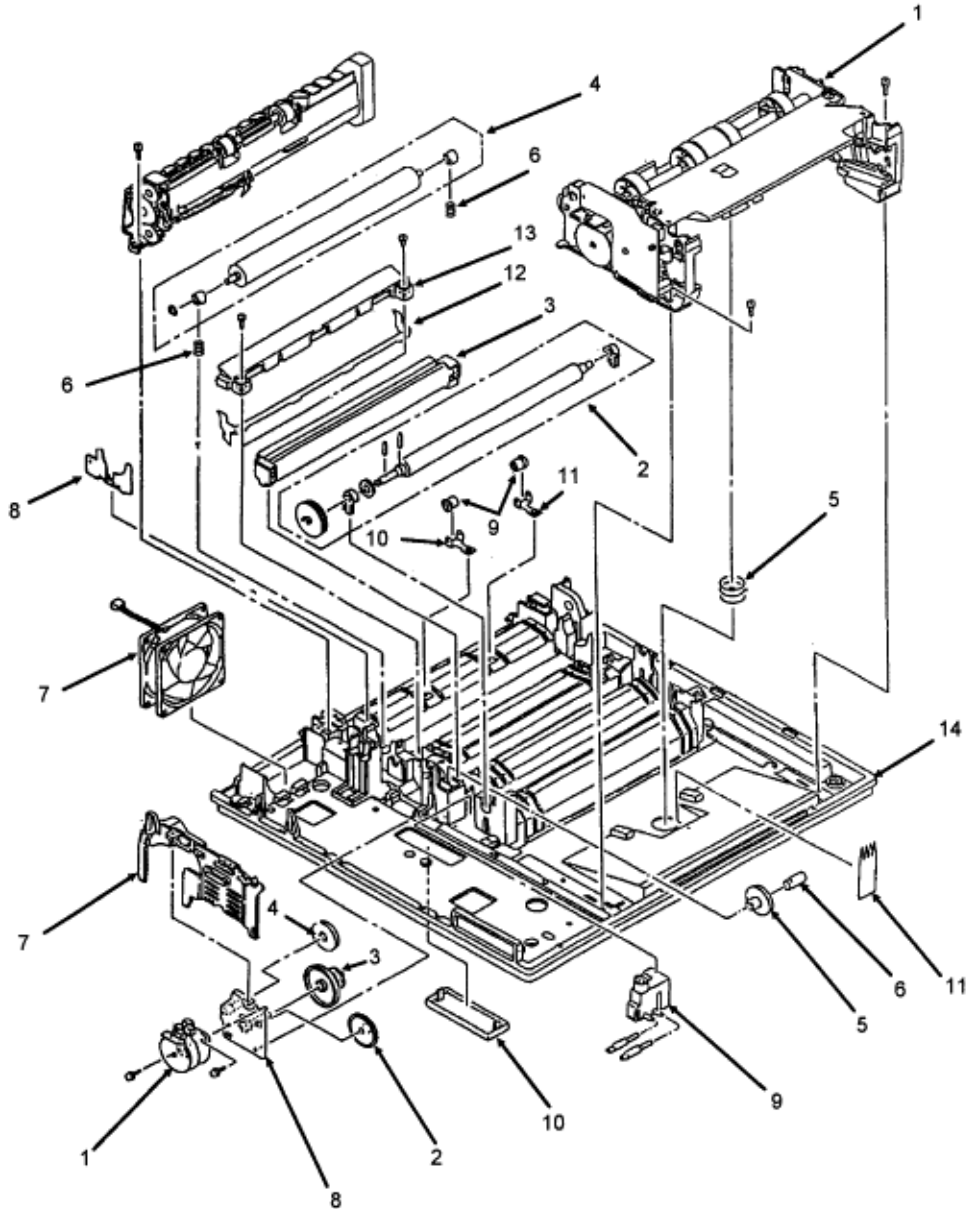

Item	Okidata P/N Oki-J P/N	Description	Comments Refer to B.1.02	Disassembly Procedure
1	50214506 4YA4083-2124G6	Unit: Paper Delivery	RSPL	3.2.30
2	50079101 3PA4083-2897G1	Roller: Registration (Assembly)	RSPL	3.2.27
3	50087401 3PA4083-3143G1	Charger: Transfer (Assembly)	RSPL	3.2.26
4	50079201 4PA4083-2896G1	Roller: Back-up (Assembly)	RSPL	3.2.25
5	50917001 4PP4083-2295P1	Spring: Cassette	RSPL	3.2.30 40
6	50914801 4PP4083-2023P1	Spring: Back-up Roller	RSPL	3.2.25
7	56508501 270A2290P00001	Fan: DC (Assembly)	RSPL	3.2.11
8	53335601 4PP4083-3041P1	Reinforcement Plate		3.2.25
9	53334601 4PP4083-2760P1	Bias Roller		3.2.14
10	50918401 4PP4083-2776P1	Bias Spring (Left)		3.2.14
11	50918501 4PP4083-2777P1	Bias Spring (Right)		3.2.14
12	51005101 3PP4083-2566G1	Fusing Guide		3.2.25
13	51003601 3PP4083-2035P1	Sheet Guide		3.2.25
14	53057801 1PP4083-2003P1	Base Frame		3.2.35

B.2.08 Lower Unit (2 of 2)

Part numbers are subject to change. Refer to Okilink II for current part numbers and pricing information.

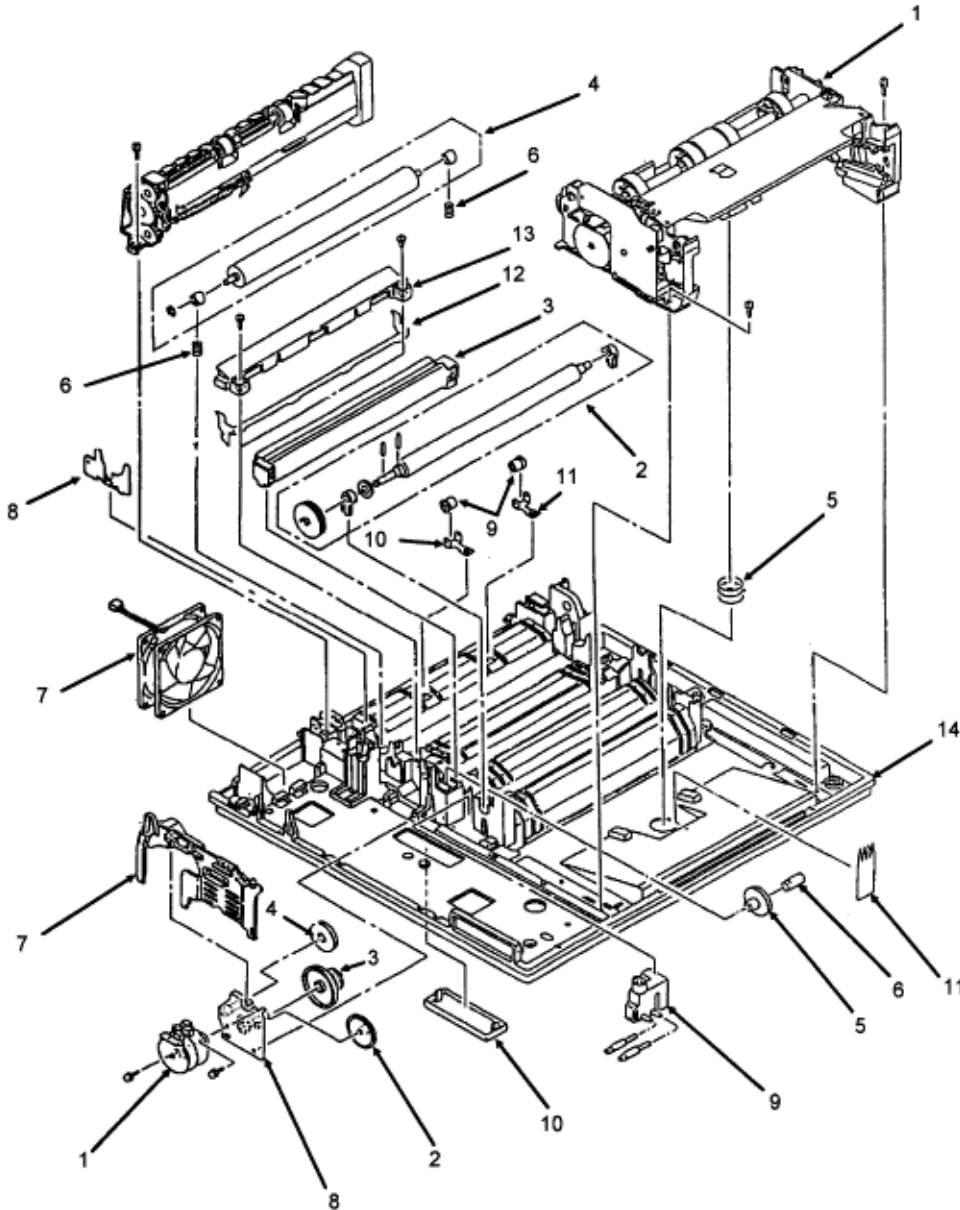

Item	Okidata P/N Oki-J P/N	Description	Comments Refer to B.1.02	Disassembly Procedure
1	56507701 3PB4083-2110P1	Motor: Pulse (Main)	RSPL	3.2.09
2	51225701 4PP4083-2593P1	Gear: Stepper Motor Idle ("A")	RSPL	3.2.10
3	51218701 3PP4083-2044P1	Gear: Speed Reduction	RSPL	3.2.10
4	51218501 4PP4083-3130P1	Gear: Idle "B"	RSPL	3.2.10
5	51218601 4PP4083-2045P1	Gear: Idle (Base)	RSPL	3.2.29
6	53329501 4PP4083-2046P1	Post	RSPL	3.2.29
7	53528301 2PP4083-2575P1	Motor Cover		3.2.09
8	53329301 4PP4083-3059G1	Motor Bracket		3.2.09
9	56725901 3PB4083-2108P1	High Voltage Connector		3.2.28
10	51901701 3PB4083-2588P1	Cap		3.2.37
11	51802501 4PB4083-2938P1	Diselectrification Cloth		3.2.30

Copyright 1997, Okidata, Division of OKI America, Inc. All rights reserved. See the OKIDATA Business Partner Exchange (BPX) for any updates to this material. (<http://bpx.okidata.com>)

B.2.09 Boards

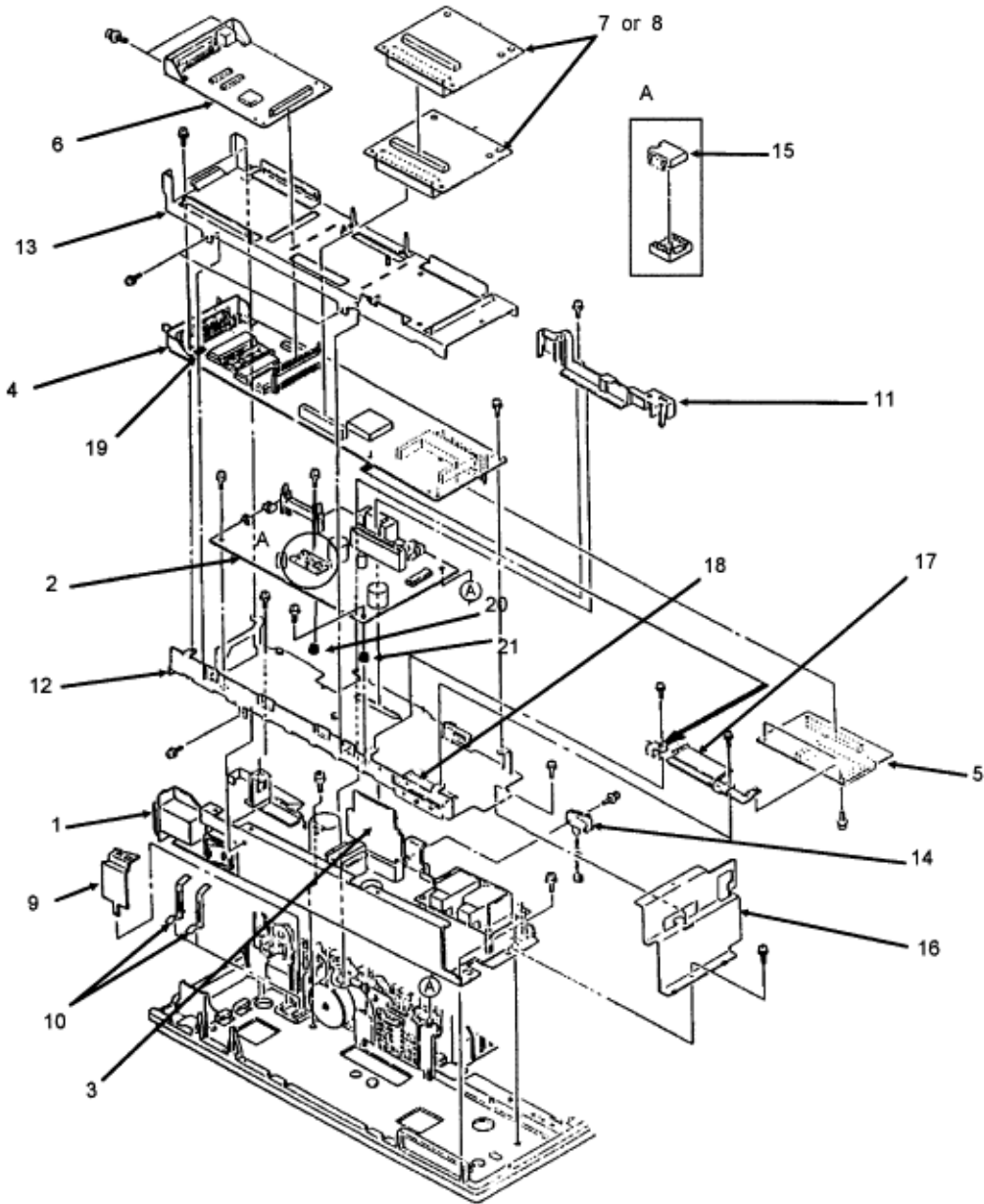

Part numbers are subject to change. Refer to Okilink II for current part numbers and pricing information.

Item	Okidata P/N Oki-J P/N	Description	Comments Refer to B.1.02	Disassembly Procedure
1	56408710 4YA4083-5017G10	Power Supply (120V)	RSPL	3.2.12
1	56408708 4YA4083-5017G8	Power Supply (220/240V)	Option	3.2.12
2	55067502 4YA4087-1022G2	PCB: LLAT-2 Eng Controller	RSPL	3.2.08
3	55046001 3PU4003-5928P1	PCB: LLID	RSPL	3.2.09
4	55067601 4YA4046-1516G1	PCB: OLMA Main	RSPL	3.2.07
5	55067701 4YA4046-1520G1	PCB: OLCA 2nd Font Card	RSPL	3.2.07
6	55067801	PCB: OLSA Serial I/F	Option	3.2.05
7	55067901 4YA4046-1518G1	PCB: OLRA 2 MB RAM	Option	3.2.06
8	55067902 4YA4046-1518G2	PCB: OLRA-2 1 MB RAM	Option	3.2.06
9	53502301 4PP4083-2103P1	AC Cover		3.2.12
10	53057901 4PP4083-2048P1	AC Contact Plate		3.2.12
11	53528401 3PP4083-2742P1	Board Cover		3.2.08
12	51008102 3PA4083-3232G2	Plate: Shield A Assembly (OL810)	RSPL	3.2.09
13	51008201 3PA4083-3228P1	Plate: Shield B	RSPL	3.2.05
14	55050721 4YX4056-4259G1	Microswitch Assembly (120V)		3.2.13
14	N/A 4YX4056-3735G2	Microswitch Assembly (220-240V)		3.2.13
15	55938201 4YA4087-1025G1	IC: Eng EEPROM BR93LC46A	RSPL	3.2.08

16	51008301 3PP4083-3233P1	Plate: Shield C	RSPL	3.2.09
17	51708201 3PP4083-3235P1	Bracket: Font Card Board	RSPL	3.2.07
18	51008401 4PP4083-3231P1	Guide: Card (C)	RSPL	3.2.07
19	55923901	IC: CU EEPROM MSM16811RS-N W	RSPL	3.2.07
20 *	50515808 143A1073P0008	Spacer: Board with 18 mm screw	RSPL	3.2.08
21 *	50515801 143A1073P0001	Spacer: Board with 5 mm screw	RSPL	3.2.08

* The spacers in items 20 and 21 are the same size.
Screws are included with each spacer.
The screw in item 20 is longer than than the screw in item 21.

Copyright 1997, Okidata, Division of OKI America, Inc. All rights reserved. See the OKIDATA Business Partner Exchange (BPX) for any updates to this material. (<http://bpx.okidata.com>)

B.2.10 Paper Eject Roller Assembly

Part numbers are subject to change. Refer to Okilink II for current part numbers and pricing information.

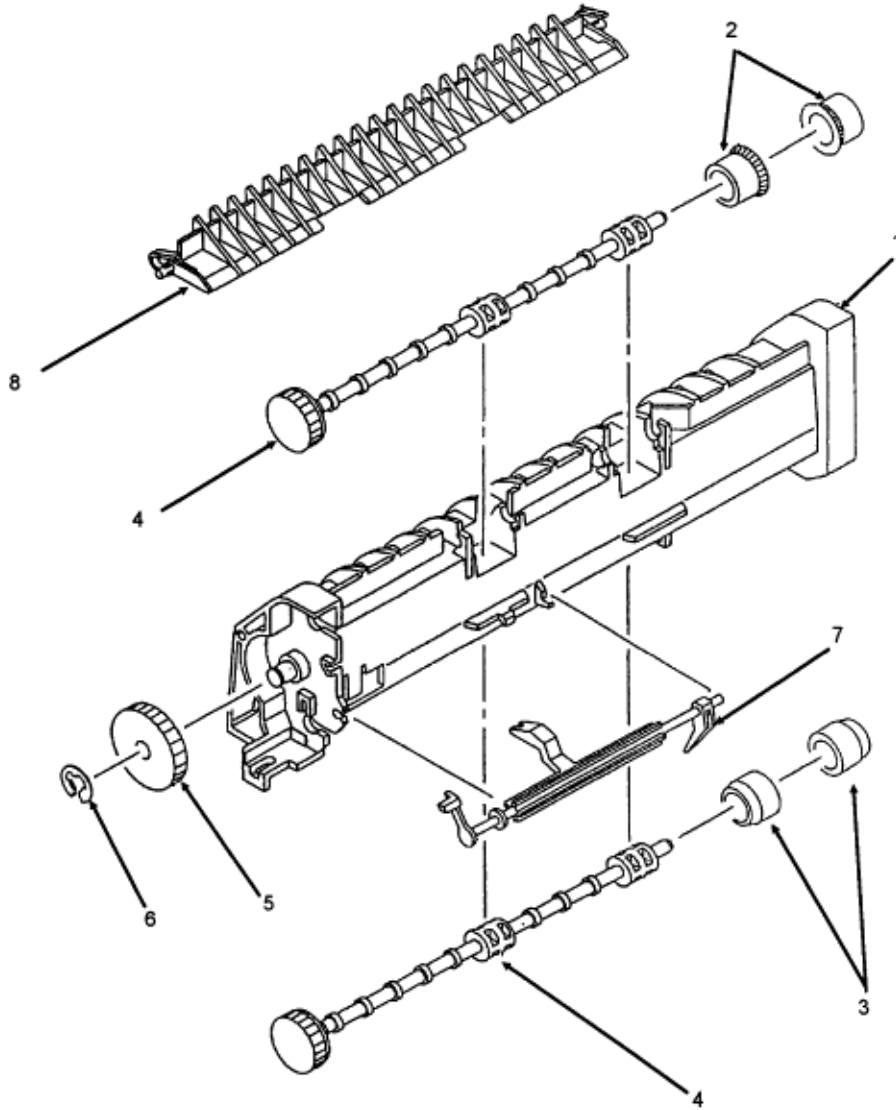

Item	Okidata P/N Oki-J P/N	Description	Comments Refer to B.1.02	Disassembly Procedure

1	N/A N/A	Paper Eject Roller Assembly	Inc 2 - 9	3.2.14
2	51005201 2PP4083-2027P1	Sheet Guide		3.2.15
3	53334401 4PB4083-2028P1	Paper Eject Roller		3.2.15
4	53334501 4PP4083-2515P1	Paper Eject Roller (Face-up)		3.2.15
5	51111401 3PP4083-2029P1	Paper Eject Roller Shaft		3.2.15
6	51222801 4PP4083-2344P1	Idle Gear (Paper Eject)		3.2.15
7	50705301 RE6-SUS	E-Ring		3.2.15
8	53528101 3PP4083-2032P1	Sensor Lever (Paper Eject)		3.2.15
9	53528201 3PP4083-2881P1	Sheet Separator		3.2.15

Copyright 1997, Okidata, Division of OKI America, Inc. All rights reserved. See the OKIDATA Business Partner Exchange (BPX) for any updates to this material. (<http://bpx.okidata.com>)

B.2.11 Paper Supply Unit

Part numbers are subject to change. Refer to Okilink II for current part numbers and pricing information.

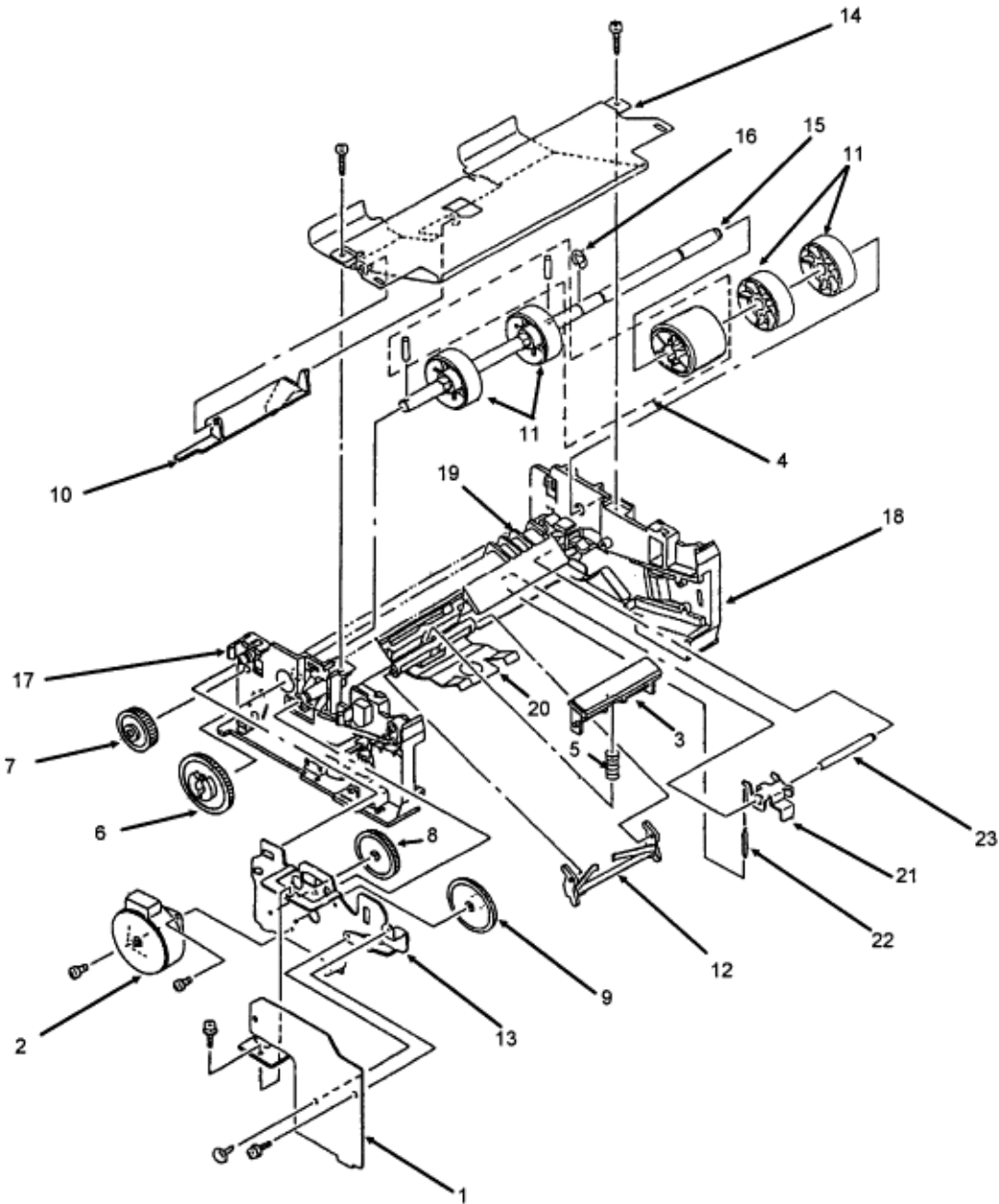

Item	Okidata P/N Oki-J P/N	Description	Comments Refer to B.1.02	Disassembly Procedure
1	55044601 4YA4083-5011G1	PCB: LLCC (Engine Connector)	RSPL	3.2.32
2	56507401 4PB4083-2275P1	Motor: Pulse (Resist)	RSPL	3.2.31 41
3	53500501 4PP4083-2255G1	Separator	RSPL	3.2.34
4	50081701 4PA4083-3105G1	Roller: Hopping (Assembly)	RSPL	3.2.33
5	50917101 4PP4083-2270P1	Spring: Separator	RSPL	3.2.34
6	51222901 3PP4083-2265P1	Hopping Gear		3.2.33
7	51223001 4PP4083-2282P1	Planet Gear		3.2.33
8	51223101 4PP4083-2279P1	Idle Gear "B"		3.2.31
9	51223201 4PP4083-2280P1	Idle Gear "C" (OL810)	RSPL	3.2.15
10	53528501 3PP4083-2268P1	Paper End Lever		3.2.33
11	53334901 3PP4083-2261P1	Hopping Roller B		3.2.33
12	53528601 3PP4083-2256P1	Escape Lever		3.2.34
13	53335002 4PP4083-3057G2	Motor Bracket		3.2.31
14	53335101 2PP4083-2269P1	Upper Plate		3.2.34
15	51111501 3PP4083-3092P1	Hopping Roller Shaft		3.2.33
16	50705401 RE6-SUS	E-Ring		3.2.33
17	53335201 3PA4083-2562G1	Side Frame Assembly (Left)		3.2.34
18	53335301 1PP4083-2252P1	Side Frame Assembly (Right)		3.2.34

19	53335401 1PP4083-2253P1	Separator Frame		3.2.34
20	53528701 3PP4083-2266P1	Setting Lever		3.2.34
21	53528801 4PP4083-2267P1	Latch Lever		3.2.34
22	50918601 4PP4083-2271P1	Latch Spring		3.2.34
23	51111601 4PP4083-2296P1	Latch Shaft		3.2.34

Copyright 1997, Okidata, Division of OKI America, Inc. All rights reserved. See the OKIDATA Business Partner Exchange (BPX) for any updates to this material. (<http://bpx.okidata.com>)

B.2.12 Options

Part numbers are subject to change. Refer to Okilink II for current part numbers and pricing information.

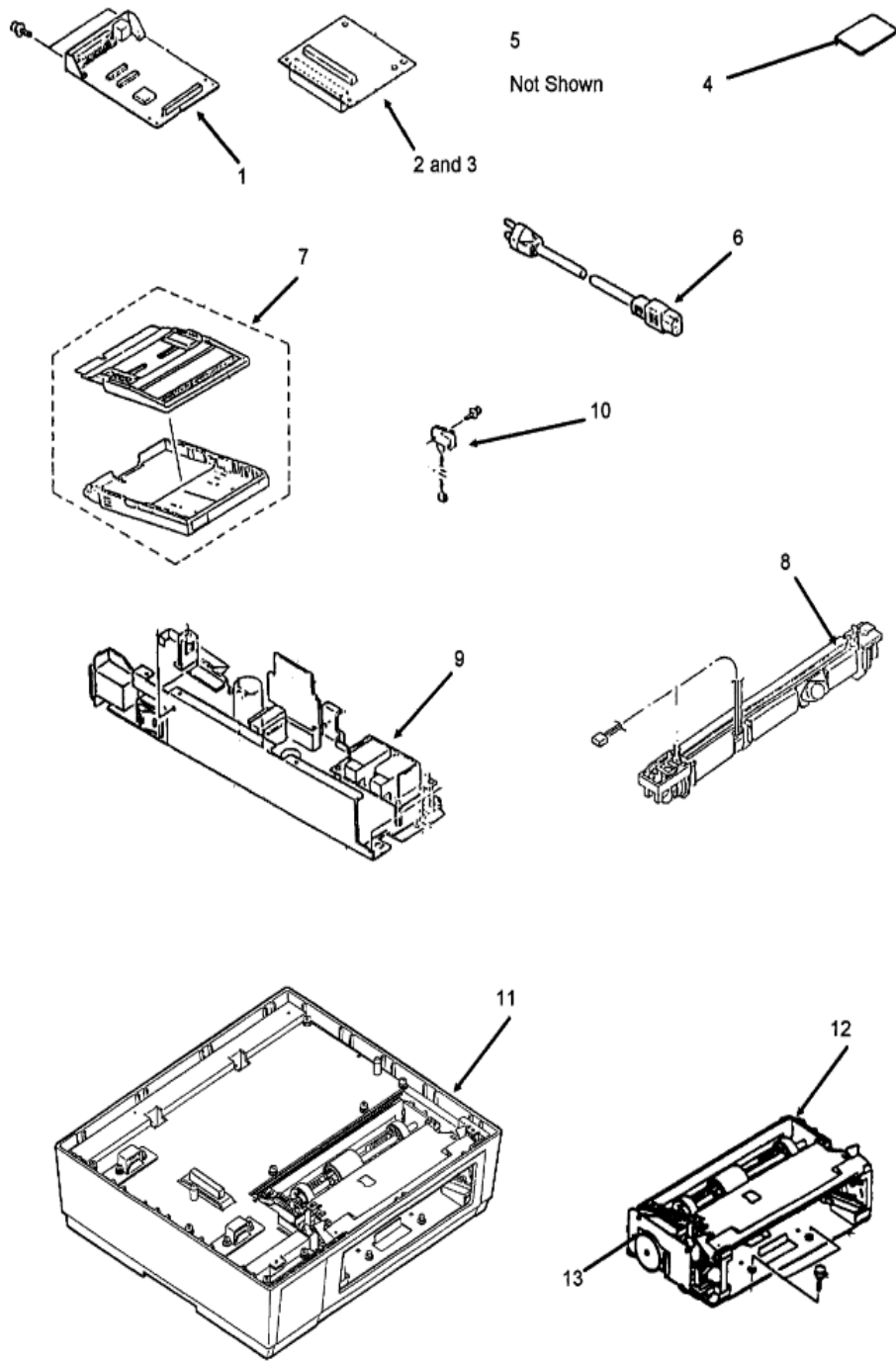

Item	Okidata P/N Oki-J P/N	Description	Comments Refer to B.1.02	Disassembly Procedure
1	55067801	PCB: OLSA Serial I/F	Option	3.2.05

2	55067901 4YA4046-1518G1	PCB: OLRA 2 MB RAM	Option	3.2.06
3	55067902 4YA4046-1518G2	PCB: OLRA-2 1 MB RAM	Option	3.2.06
5	50213707 1YX4083-2060G7	Unit: Upper (220/240V)	Option	3.2.16
6	56624301 3YS4011-1266P1	Cord: AC (220V)	Option	3.2.01
6	56624501 3YS4011-1270P1	Cord: AC 240 V (OL Series) UK	Option	3.2.01
8	55044902 2YX4083-2073G4	Unit: Fusing (220/240V)	Option RSPL	3.2.19
9	56408708 4YA4083-5017G8	Power Supply (220/240V)	Option	3.2.12
10	N/A 4YX4056-3735G2	Microswitch Assembly (220-240V)		3.2.13
11	70018601 N/A	Second Paper Feed Unit	Option	3.2.37
12	50063501 1YX4083-2285G1	Second Paper Supply Unit	Option RSPL	3.2.39
13	55051401 4YA4083-5015G1	PCB: LLFC (2nd Tray)	Option RSPL	3.2.42
14 *	70021201	Serial Interface Kit	Option	3.2.05
15 *	70021001	1 MB Memory Board Kit	Option	3.2.06
16 *	70021101	2 MB Memory Board Kit	Option	3.2.06
17 *	70022101	Adobe PostScript Kit	Option	N/A

* This item is not shown.



Service Guide OL810

Chapter B Illustrated Parts Listing

B.2.13 Font Cards

Part numbers are subject to change. Refer to Okilink II for current part numbers and pricing information.'

Item	Okidata P/N Oki-J P/N	Description	Comments Refer to B.1.02	Disassembly Procedure
1 *	70017101	Bar Code Plus	Option	3.2.01
1 *	70021401	Dazzling Presentations	Option	3.2.01
1 *	70017201	Micro Docs	Option	3.2.01
1 *	70017301	OkiPro 65	Option	3.2.01
1 *	70014001	Roman Font Card (S2)	Option	3.2.01
1 *	70021301	Special Documents	Option	3.2.01
1 *	70021501	WP Scalable	Option	3.2.01
1 *	70014501 4YB4060-4145P20	Font ROM Card (Letter Gothic)	Option	3.2.01
1 *	70014201 4YB4060-4145P18	Font ROM Card (Prestige Elite)	Option	3.2.01
1 *	70014401 4YB4060-4144P7	Font ROM Card (Tax)	Option	3.2.01

* This item is not shown.

B.2.14 Second Paper Feed Unit

Part numbers are subject to change. Refer to Okilink II for current part numbers and pricing information.

1 includes all items shown.

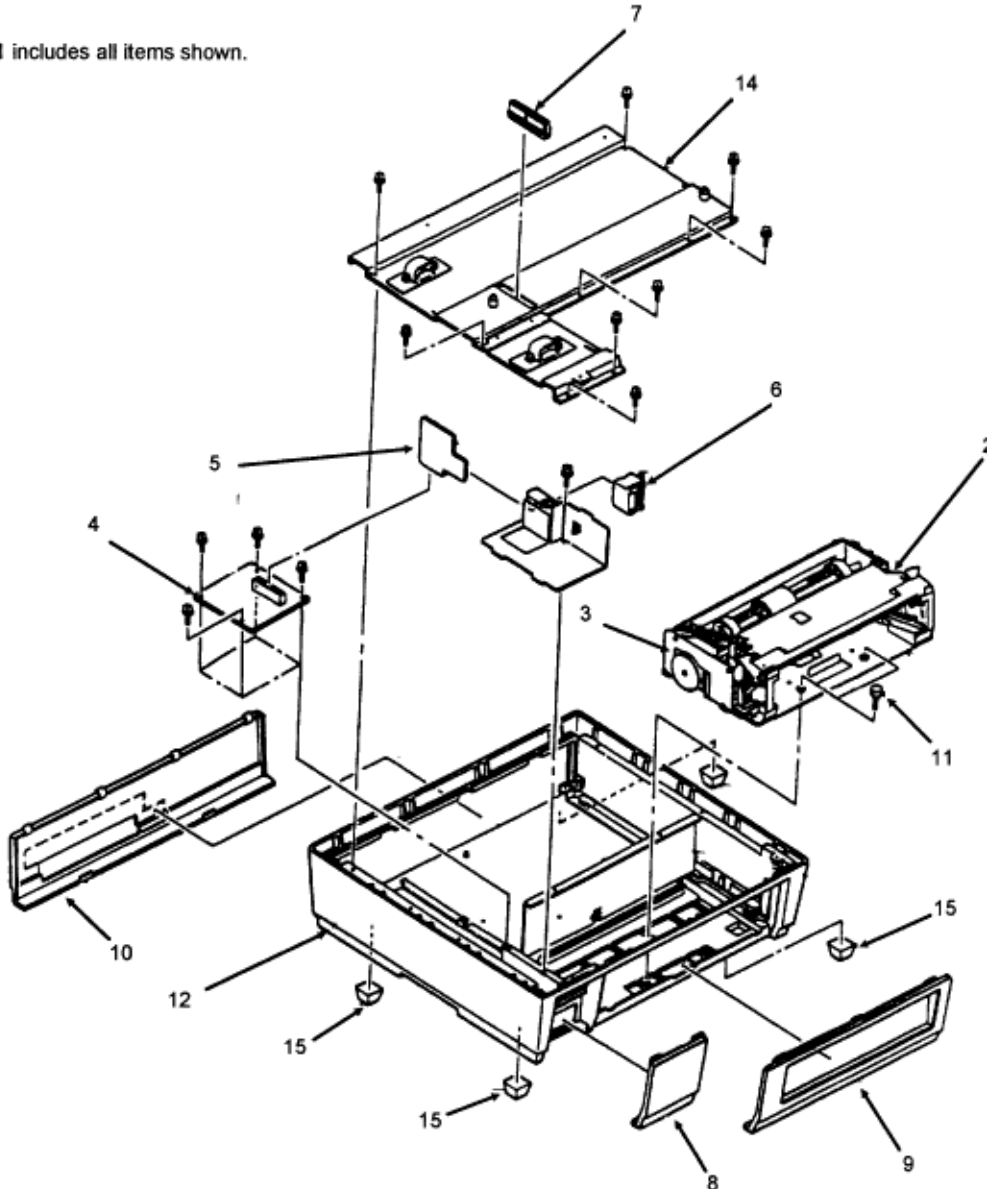

Item	Okidata P/N Oki-J P/N	Description	Comments Refer to B.1.02	Disassembly Procedure
1	70018601 N/A	Second Paper Feed Unit Includes all items shown	Option Inc. 2 - 15	3.2.37
2	50063501 1YX4083-2285G1	Second Paper Supply Unit	Option RSPL Part of 1	3.2.39
3	55051401 4YA4083-5015G1	PCB: LLFC (2nd Tray)	Option RSPL Part of 1	3.2.42
4	55067001 4YR4046-1496G1	PCB: LLIF	Part of 1	3.2.38
5	55067101 3PU4009-1238P1	Connection PCB (LLIG)	Part of 1	3.2.38
6	56726001 224A1282P0081	Connector PM8DOX	Part of 1	3.2.38
7	56725201 224A1157P0401	Connector AKJ-40AG	Part of 1	3.2.38
8	N/A 2PP4016-6855P1	Blind Cover	Part of 1	3.2.37
9	53059501 1PP4016-6792P1	Blind Cover	Part of 1	3.2.37
10	N/A 3PA4094-4233G1	Blind Cover (Rear Panel)	Part of 1	3.2.37
11	N/A 4PP4083-3109P1	Thumb Screw	Part of 1	3.2.37
12	53059401 1PP4016-6791P1	Lower Base	Part of 1	3.2.37
13	N/A 2PP4094-4999G1	Shield Base	Part of 1	3.2.37
14	N/A 2PA4094-5002G2	Top Plate Assembly	Part of 1	3.2.37
15	53505301 4PB4020-1510P1	Rubber Foot	Part of 1	3.2.37



B.2.15 Packing Materials

Part numbers are subject to change. Refer to Okilink II for current part numbers and pricing information.

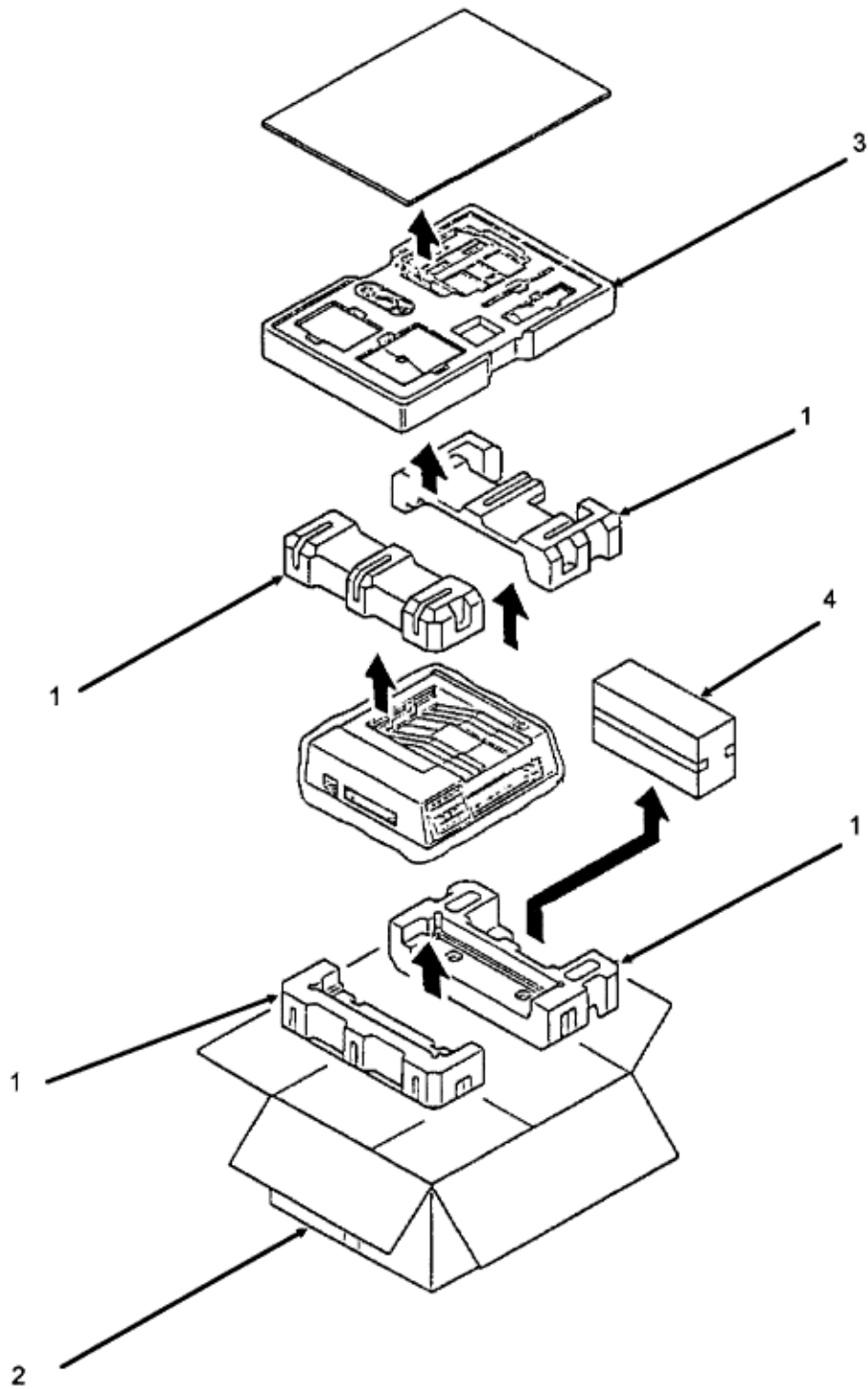

Item	Okidata P/N Oki-J P/N	Description	Comments Refer to B.1.02	Disassembly Procedure

1	53557201 3PP4083-3250P1	Foam: Packaging (OL400/830/810)	RSPL	N/A
2	53555903 N/A	Box: Graphic (OL810)	RSPL	N/A
3	53564801	Tray: OL Series Accessory	RSPL	N/A
4	53562003 N/A	Assembly: Image Drum Repackaging	RSPL	N/A
5 *	53422613	Bag: Black Velostat	RSPL	N/A

* This item is not shown.

Copyright 1997, Okidata, Division of OKI America, Inc. All rights reserved. See the OKIDATA Business Partner Exchange (BPX) for any updates to this material. (<http://bpx.okidata.com>)



B.2.16 Consumables

Part numbers are subject to change. Refer to Okilink II for current part numbers and pricing information.

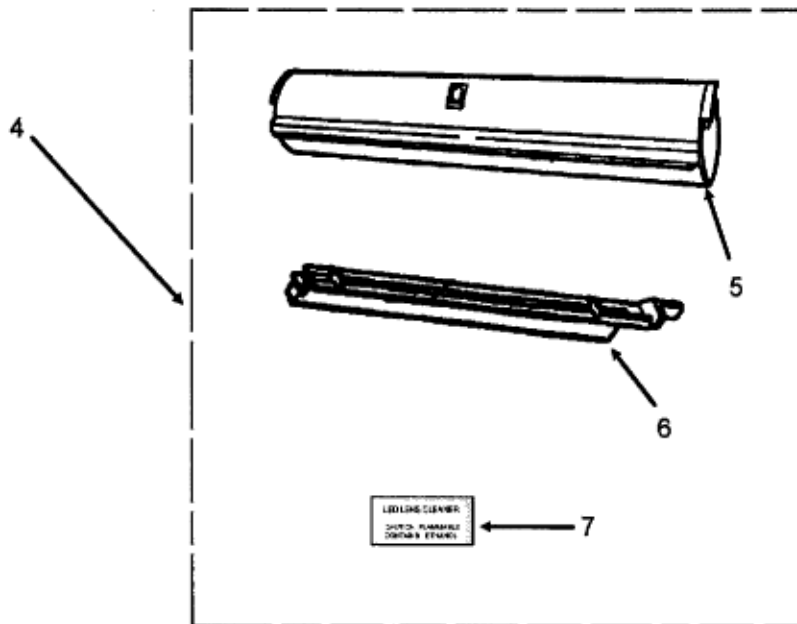
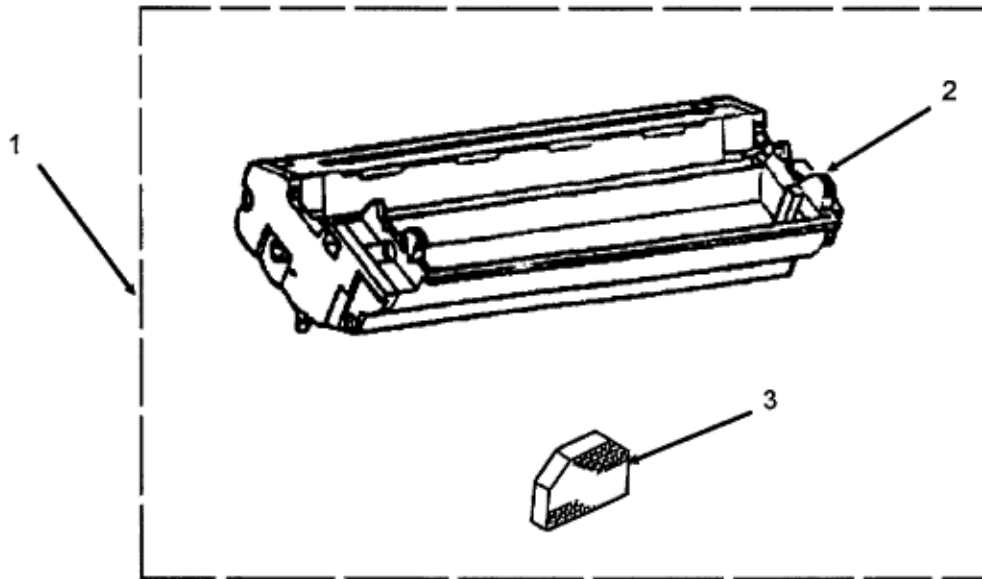

Item	Okidata P/N Oki-J P/N	Description	Comments Refer to B.1.02	Disassembly Procedure
1	56106601 4YA4083-3201G1	Image Drum Kit	Consumable Inc 2 and 3	3.2.01

2	N/A N/A	Image Drum Cartridge	Consumable Part of 1	3.2.01
3	55503501 3PB4083-2816P2	Filter: Ozome	Consumable Part of 1	3.2.36
4	52104201 4YA4083-3202G1	Toner Cartridge Kit	Consumable Inc 5 6 7	3.2.01
5	N/A N/A	Toner Cartridge	Consumable Part of 4	3.2.01
6	53500901 3PB4083-2096P1	Pad: Fuser	Consumable Part of 4	3.2.19
7	N/A N/A	LED Lens Cleaner	Consumable Part of 4	N/A

Copyright 1997, Okidata, Division of OKI America, Inc. All rights reserved. See the OKIDATA Business Partner Exchange (BPX) for any updates to this material. (<http://bpx.okidata.com>)



Service Guide OL810

Chapter B Illustrated Parts Listing

B.2.17 Documentation

Part numbers are subject to change. Refer to Okilink II for current part numbers and pricing information.

Item	Okidata P/N Oki-J P/N	Description	Comments Refer to B.1.02	Disassembly Procedure
1 #	58225901	Kit: OL810 Service Training	Document	N/A
1 #	58225902	Kit: OL810 Service Training	Document	N/A
1 #	58225903	Kit: OL810 Service Training	Document	N/A
2	59250201	Manual: Maintenance	Document	N/A
3	59254091	Manual: Troubleshooting	Document	N/A
4	59249901	Product Specifications	Document	N/A
5	58227402	Package: User's Documentation	Document Inc. 7 - 10	N/A
6	58083502	Sheet: License Agreement	Document Part of 6	N/A
7	59222903	Booklet: Font and Accessory	Document Part of 6	N/A
8	59250402	Handbook: Printer	Document Part of 6	N/A
9	53436027	Bag: Zip Lock 8" x 10"	Document Part of 6	N/A

* To order Marketing Literature, complete an Okidata Marketing Literature Order Form. Fax the completed form to Okidata Marketing Communications.

** Obtain this form by faxing a request to Okidata Marketing Communications. Refer to the Service Center Reference Guide for information on contacting Okidata.

See the following pages

Item	Okidata P/N Oki-J P/N	Description	Comments Refer to B.1.02	Disassembly Procedure
10	N/A N/A	Okidata Service Center Reference Guide	Document	N/A
11	53547501 N/A	Okidata Support 3-Ring Binder	Document	N/A
12	58067201 N/A	ABCD Warranty Claim Forms (Pkg of 20)	Document	N/A
13	58052401 N/A	Warranty Summary Forms (Pkg of 20)	Document	N/A
14	N/A N/A	Printer Drivers	Refer to Okilink	N/A
15	N/A N/A	Product Updates	Document Refer to Okilink	N/A
16	N/A N/A	Recommended Spare Parts List	Document Refer to Okilink	N/A
17	N/A N/A	Software	Refer to Okilink	N/A
18	N/A N/A	Technical Service Bulletins	Document Refer to Okilink	N/A
19 *	N/A N/A	Marketing Literature	Document	N/A
20 **	N/A N/A	Okidata Marketing Literature Order Form	Document	N/A

* To order Marketing Literature, complete an Okidata Marketing Literature Order Form. Fax the completed form to Okidata Marketing Communications.

** Obtain this form by faxing a request to Okidata Marketing Communications. Refer to the Service Center Reference Guide for information on contacting Okidata.

See the following pages



Service Guide OL810

Chapter B Illustrated Parts Listing

B.2.18 Service Training Kit Revisions

P/N 58225901 OL810 Service Training Kit

This kit was replaced by P/N 58225902.

Items in the training kit (except for the Printer Handbook) are NOT available separately.

Item	Okidata P/N Oki-J P/N	Description	Comments Refer to B.1.02	Disassembly Procedure
1A	58225901	Kit: OL810 Service Training	Document Both	N/A
2A	52054901	Label: OL810 Kit	Document	N/A
3A	58226001	Package: Administration	Document	N/A
4A	58226001	Envelop: Administration Package	Document	N/A
5A	58078501	Letter: Cover	Document	N/A
6A	59251301	Guide: Training	Document	N/A
7A	58078601	Test: Certification	Document	N/A
8A	58078701	Sheet: Test Answer	Document	N/A
9A	57078801	Critique: Course	Document	N/A
10A	58078901	Envelope: Pre-Printed Return	Document	N/A
11A	59226301	Introduction to Xerography	Document	N/A
12A	59251401	Handbook: OL810 Service	Document	N/A
13A	59251501	Documentation: User's	Document	N/A
14A	59250401	Printer Handbook	Document	N/A

15A	57518501	Video: OL810 Service Training	Document	N/A
16A	52054902	Label: OL810 Video Case	Document	N/A
16A	52054903	Label: OL810 Video (Front)	Document	N/A
18A	52054904	Label: OL810 Video (Spine)	Document	N/A
19A	57517101	Case: Red Vinyl Video	Document	N/A
20A	53533001	Box: Storage	Document	N/A

P/N 58225902 OL810 Service Training Kit

This kit was replaced by P/N 58225903.

Items in the training kit (except for the Printer Handbook) are NOT available separately.

Item	Okidata P/N Oki-J P/N	Description	Comments Refer to B.1.02	Disassembly Procedure
1B	58225902	OL810 Service Training Kit	Document	N/A
2B	52054905	Label: OL810 Kit	Document	N/A
3B	58226002	Package: Administration	Document	N/A
4B	58226002	Envelope: Administration Package	Document	N/A
5B	58078502	Letter: Cover	Document	N/A
6B	59251302	Guide: Training	Document	N/A
7B	58078602	Test: Certification	Document	N/A
8B	58078702	Sheet: Test Answer	Document	N/A
9B	57078802	Critique: Course	Document	N/A
10B	58079802	Envelope: Pre-Printed Return	Document	N/A
11B	59226301	Introduction to Xerography	Document	N/A

12B	59251402	Handbook: OL810 Service	Document	N/A
13B	59251502	Documentation: User's	Document	N/A
14B	58077901	Handbook: Addendum	Document	N/A
15B	58077801	Product Update	Document	N/A
16B	59250401	Printer Handbook	Document	N/A
17B	57518501	Video: OL810 Service Training	Document	N/A
18B	52054902	Label: OL810 Video Case	Document	N/A
19B	52054903	Label: OL810 Video (Front)	Document	N/A
20B	52054904	Label: OL810 Video (Spine)	Document	N/A
21B	57517101	Case: Red Vinyl Video	Document	N/A
22B	53567001	Box: Storage	Document	N/A
23B	53567101	Sleeve: Cardboard	Document	N/A

P/N 58225903 OL810 Service Training Kit

This kit replaces P/N 58225902.

Items in the training kit (except for the Printer Handbook) are NOT available separately.

Item	Okidata P/N Oki-J P/N	Description	Comments Refer to B.1.02	Disassembly Procedure
1C	52054906	Label: OL810 Kit	Document	N/A
2C	58078503	Sheet: Read Me First	Document	N/A
3C	59251403	Handbook: OL810 Service	Document	N/A
4C	59250402	Handbook: OL810 Printer	Document	N/A
5C	57518501	Video: OL810 Service Training	Document	N/A

6C	52054904	Label: OL810 Video (Spine)	Document	N/A
7C	53570401	Sleeve: Videotape (Cardboard)	Document	N/A

Copyright 1997, Okidata, Division of OKI America, Inc. All rights reserved. See the OKIDATA Business Partner Exchange (BPX) for any updates to this material. (<http://bpx.okidata.com>)